

COMMANDER C1900 Series
Circular Chart Recorders

Operating Instructions

MODBUS (RTU)
Communications Option



ABB INSTRUMENTATION

The Company

ABB Instrumentation is an established world force in the design and manufacture of instrumentation for industrial process control, flow measurement, gas and liquid analysis and environmental applications.

As a part of ABB, a world leader in process automation technology, we offer customers application expertise, service and support worldwide.

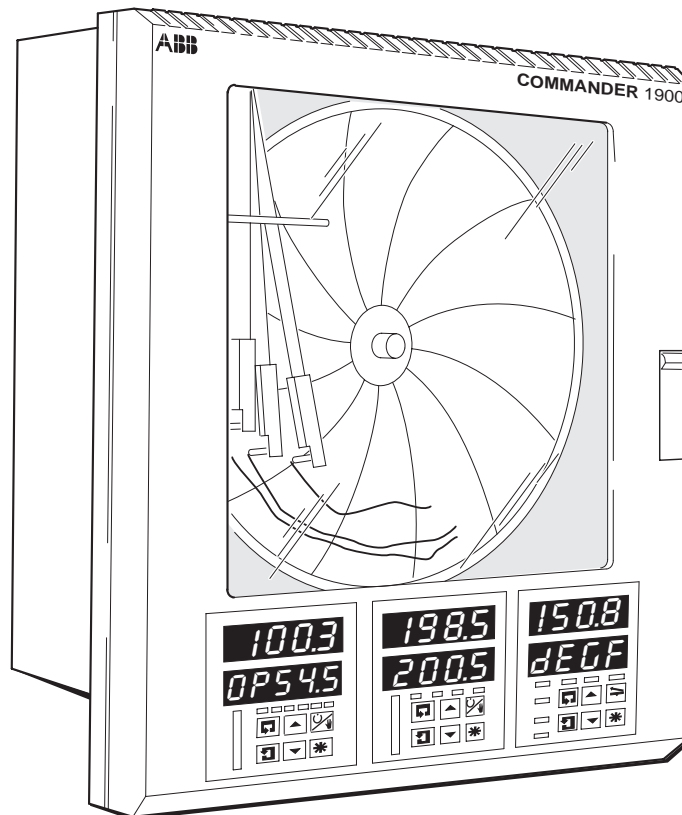
We are committed to teamwork, high quality manufacturing, advanced technology and unrivalled service and support.

The quality, accuracy and performance of the Company's products result from over 100 years experience, combined with a continuous program of innovative design and development to incorporate the latest technology.

The NAMAS Calibration Laboratory No. 0255(B) is just one of the ten flow calibration plants operated by the Company, and is indicative of ABB Instrumentation's dedication to quality and accuracy.

BS EN ISO 9001



St Neots, U.K. – Cert. No. Q5907
Stonehouse, U.K. – Cert. No. FM 21106

EN 29001 (ISO 9001)



Lenno, Italy – Cert. No. 9/90A



Stonehouse, U.K. – Cert. No. 0255

Use of Instructions



Warning.

An instruction that draws attention to the risk of injury or death.



Note.

Clarification of an instruction or additional information.



Caution.

An instruction that draws attention to the risk of damage to the product, process or surroundings.



Information.

Further reference for more detailed information or technical details.

Although **Warning** hazards are related to personal injury, and **Caution** hazards are associated with equipment or property damage, it must be understood that operation of damaged equipment could, under certain operational conditions, result in degraded process system performance leading to personal injury or death. Therefore, comply fully with all **Warning** and **Caution** notices.

Information in this manual is intended only to assist our customers in the efficient operation of our equipment. Use of this manual for any other purpose is specifically prohibited and its contents are not to be reproduced in full or part without prior approval of Technical Communications Department, ABB Instrumentation.

Health and Safety

To ensure that our products are safe and without risk to health, the following points must be noted:

1. The relevant sections of these instructions must be read carefully before proceeding.
2. Warning labels on containers and packages must be observed.
3. Installation, operation, maintenance and servicing must only be carried out by suitably trained personnel and in accordance with the information given.
4. Normal safety precautions must be taken to avoid the possibility of an accident occurring when operating in conditions of high pressure and/or temperature.
5. Chemicals must be stored away from heat, protected from temperature extremes and powders kept dry. Normal safe handling procedures must be used.
6. When disposing of chemicals ensure that no two chemicals are mixed.

Safety advice concerning the use of the equipment described in this manual or any relevant hazard data sheets (where applicable) may be obtained from the Company address on the back cover, together with servicing and spares information.

CONTENTS

Section	Page
1 INTRODUCTION	1
2 ELECTRICAL INSTALLATION	2
2.1 Selection of Serial Communication Adaptors for Personal Computers	2
2.2 Recommended OPTO22 Boards	2
2.3 Pull-up and Pull-down Resistors	2
2.4 Termination Resistors	4
2.5 RS485/422 Standard	4
2.6 Serial Connections	5
3 ADVANCED CONFIGURATION LEVEL	6
3.1 Serial Data Communication Page	7
4 MODBUS PROTOCOL	8
4.1 Introduction to Modbus Protocol	8
4.1.1 Non-volatile Memory Limitations	8
4.2 Modbus Function Codes	8
5 MODBUS FUNCTIONS	9
5.1 Read Coil Status – Function Code 01	9
5.1.1 Read Coil Status Query	9
5.1.2 Read Coil Status Response	9
5.2 Read Holding Register – Function Code 03	9
5.2.1 Read Holding Register Query	9
5.2.2 Read Holding Register Response	10
5.3 Force Single Coil – Function Code 05	10
5.3.1 Force Single Coil Query	10
5.3.2 Force Single Coil Response	10
5.4 Preset Single Register – Function Code 06 ..	11
5.4.1 Preset Single Register Query	11
5.4.2 Preset Single Register Response	11
5.5 Loopback Test – Function Code 08	11
5.5.1 Loopback Test Query	11
5.5.2 Loopback Test Response	11
5.6 Write Multiple Registers – Function Code 16	12
5.6.1 Write Multiple Registers Query	12
5.6.2 Write Multiple Registers Response ..	12
6 EXCEPTION RESPONSES	13
6.1 Examples	13
7 MODBUS REGISTERS	14
7.1 Coils	14
7.2 Holding Registers	16
7.3 Controller Settings/Outputs	17
7.4 Set Points	18
7.5 Alarm Settings	18
7.6 Chart Settings	19
7.7 Ramp/Soak Settings	19
7.8 Totalizer Settings	20
7.9 Holding Registers – Pasteurizer Versions Only	21

1 INTRODUCTION



Information.

- The COMMANDER 1900 Series is extended by the addition of a serial data communication option designed for use with SCADA systems.
- RS422/485 Communication standard.
- Modbus RTU protocol – for master (host computer) to slave (COMMANDER 1900) system.
- Isolated (500V) from rest of instrument.
- 3 and 5 Wire communication supported.
- Baud rate – from 1200 to 9600.
- Parity-checking – of message available.

2 ELECTRICAL INSTALLATION

2.1 Selection of Serial Communication Adaptors for Personal Computers

i **Information.**

- A RS422/485 communication board is required in the host PC.
- Observe the limitations outlined in the Installation Guide – the maximum serial data transmission line length for both RS422 and RS485 systems is 1200m.

An RS422/485 communications adaptor is required for serial links. It is strongly recommended that the card used has galvanic isolation to protect the computer from lightning damage and increase immunity from noise pick-up.

2.2 Recommended OPTO22 Boards

The following OPTO22 boards are recommended for use with the COMMANDER 1900 Series of instruments:

Part No.	Computer Type
AC24 AT	AT Bus IBM PC compatible
AC34	Microchannel IBM PC

2.3 Pull-up and Pull-down Resistors – Figs. 2.1 and 2.2

To prevent false triggering of the slave (COMMANDER 1900) by the presence of noise when the master (host computer) is inactive, 1.8K pull-up and pull-down resistors must be fitted to the RS422/485 adaptor card – see Figs. 2.1 and 2.2.

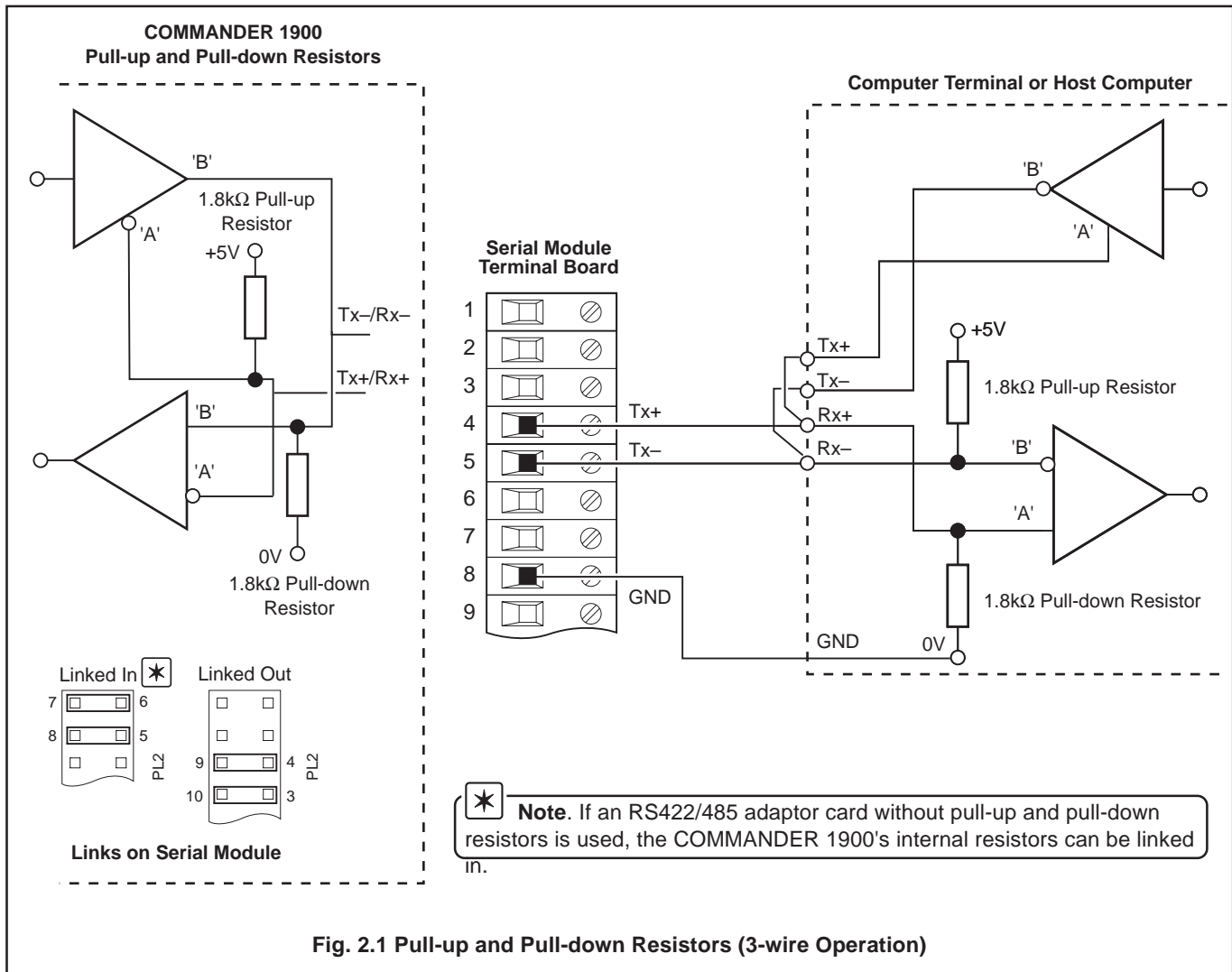

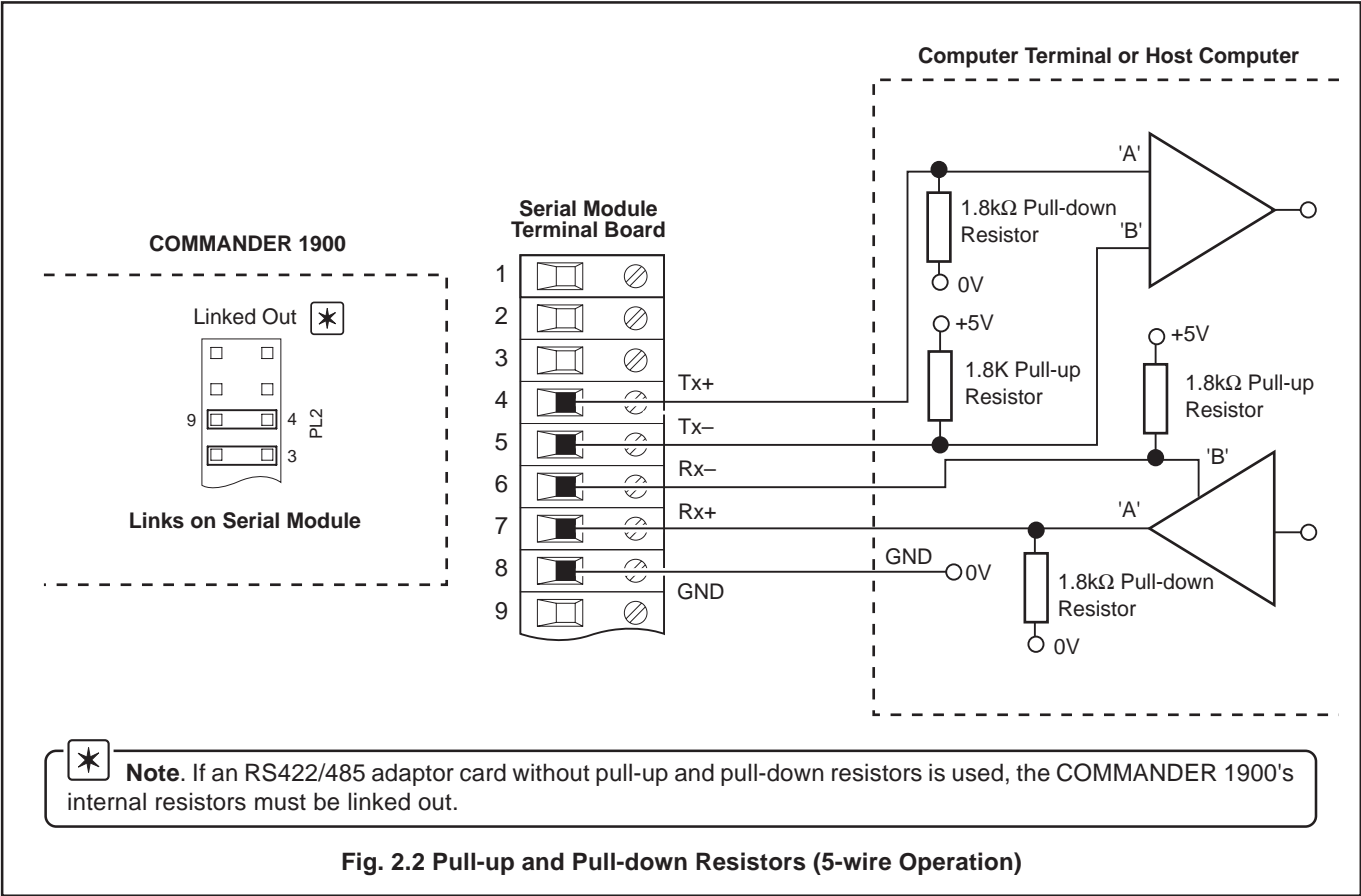

...2 ELECTRICAL INSTALLATION

2.4 Termination Resistors – Fig. 2.3

For long transmission lines, termination resistors are required on the last slave in the chain and the host computer/computer terminal – see Fig. 2.3. Under normal operating conditions the resistors are required at the receive inputs only. For 3-wire operation the slave termination resistor is fitted to the serial module terminal board – see Fig. 2.3A. For 5-wire operation the slave termination resistor is selected using plug-in links on the serial module – see Fig. 2.3B.

2.5 RS485/422 Standard

The RS485 standard quotes connection of thirty two slaves maximum, to any single driver (computer terminal or host computer); the RS422 standard quotes connection of up to ten slaves. However, these numbers can be increased if the driver's serial port permits.

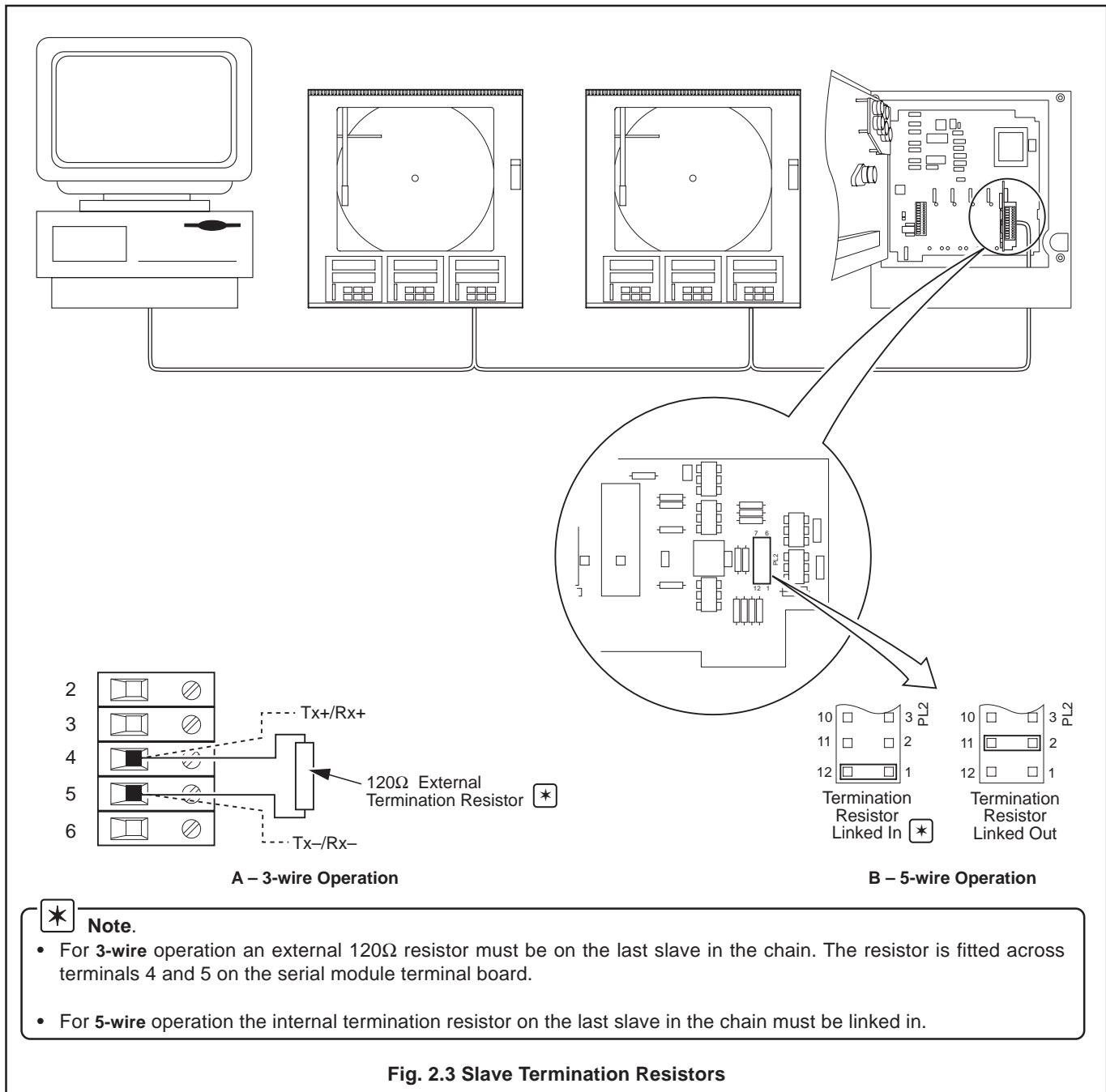

2.6 Serial Connections – Fig. 2.4



Information.

- Up to **10 slaves** can be connected to a single **RS422** adaptor card on a PC.
- Up to **32 slaves** can be connected to a single **RS485** adaptor card on a PC.
- The maximum serial data transmission line length for both **RS422** and **RS485** systems is 1200m.

All connections, apart from those for serial data communication, are made as shown in *Section 4 of the Installation Guide*.

Make serial data connections as shown in Fig. 2.4. The type of cable used is dependent on the cable length:

- Up to 6m** – standard screened or twisted pair cable
- Up to 300m** – twin twisted pair with overall foil screen and an integral drain wire, e.g. Belden 9502 or equivalent
- Up to 1200m** – twin twisted pair with separate foil screens and integral drain wires for each pair, e.g. Belden 9729 or equivalent

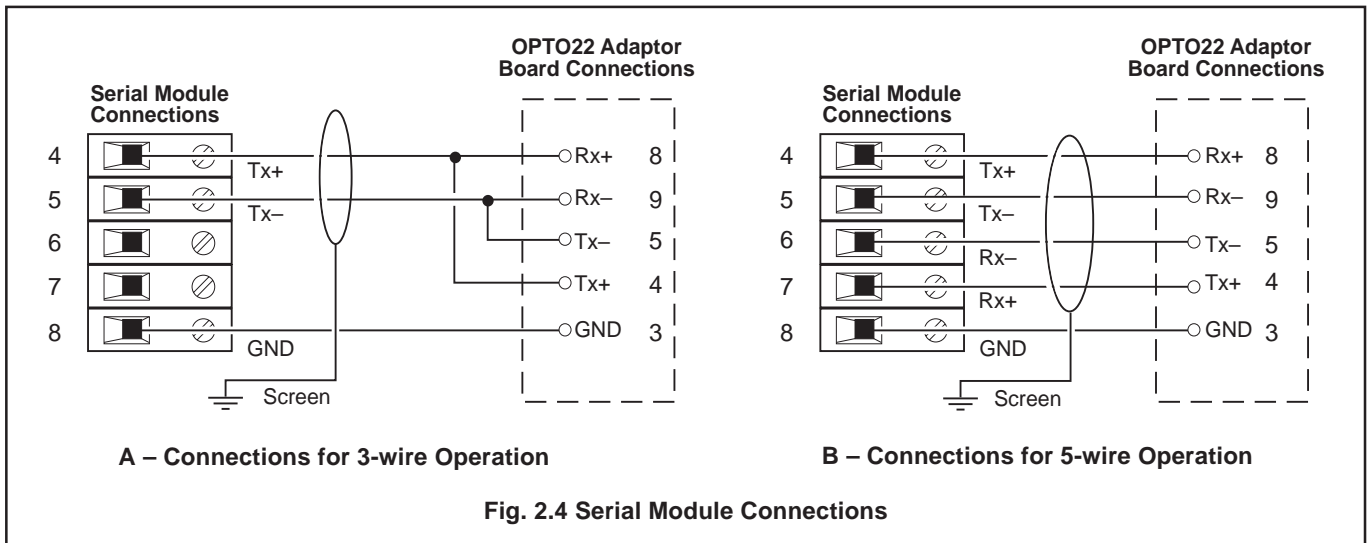

COMMANDER 1900 Serial Module Terminal Board		OPTO22 Board Pin Identification	
Terminal Number	Connections	Part Number AC24 AT & AC34	Connections
4	TX+	4	TX+
5	TX-	8	RX+
8	GND	5	TX-
		9	RX-
		3	GND

Table 2.1 Terminal and Pin Identification for 3-wire Operation

COMMANDER 1900 Serial Module Terminal Board		OPTO22 Board Pin Identification	
Terminal Number	Connections	Part Number AC24 AT & AC34	Connections
4	TX+	8	RX+
5	TX-	9	RX-
7	RX+	4	TX+
6	RX-	5	TX-
8	GND	3	GND

Table 2.2 Terminal and Pin Identification for 5-wire Operation

3 ADVANCED CONFIGURATION LEVEL

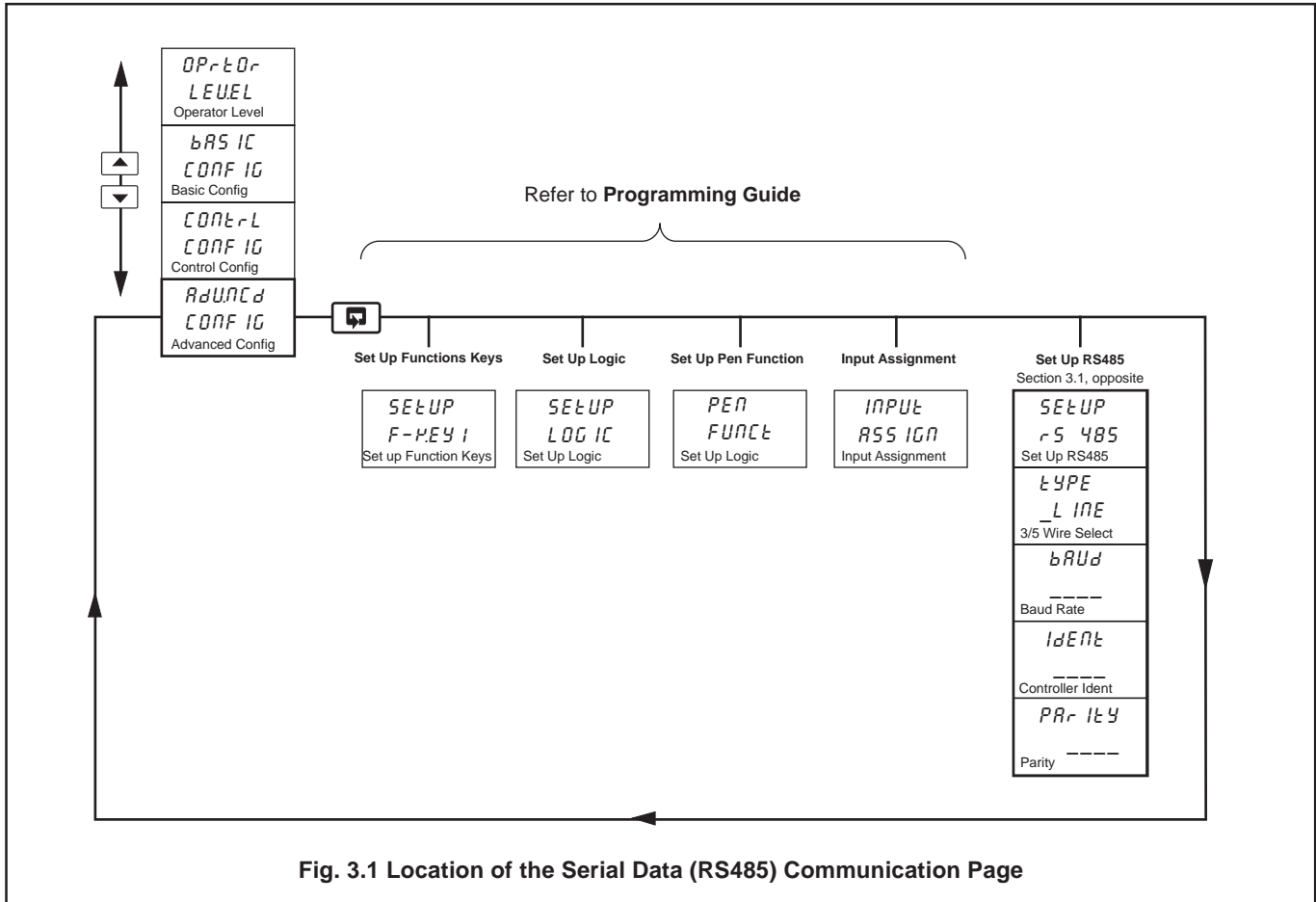

Fig. 3.1 Location of the Serial Data (RS485) Communication Page

3.1 Serial Data Communication Page



Information.

- Programmable for 3 or 5 wire connections.
- Programmable baud rate (1200 to 9600 baud).
- Odd or even parity.

The general programming procedure is as detailed in the **Operating Guide**. In this Section, parameters in the lower display denoted ■ are Company Standard Settings. The instrument is dispatched programmed with these settings.

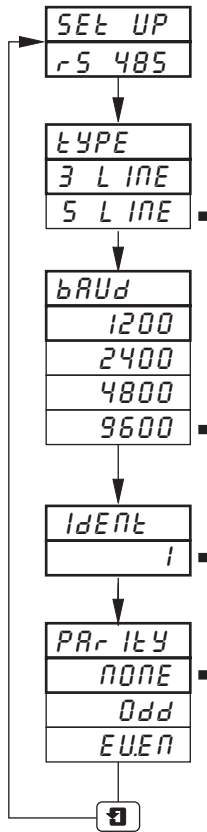

Page Header – **Set Up RS485.**

Connection Type

Select the required number of transmission wires (3 line, 5 line).

Transmission Rate

Select the transmission rate required (1200 slowest, 9600 fastest).

Controller Identification

Assign the controller an identification number between 1 and 99.

Parity

Select the appropriate parity to match the computer terminal or host computer.

Return to **Set Up RS485** frame.

4 MODBUS PROTOCOL



Information.

- The COMMANDER 1900 operates as a Modbus, Remote Terminal Unit (RTU) slave.
- Parity checking – used to detect transmission errors in individual characters.
- Cyclic redundancy checking – used to detect errors in the master messages and slave responses.
- Non-volatile memory save command.

4.1 Introduction to Modbus Protocol

Modbus communication is based on a master and a slave arrangement. The master sends a message to one slave at a time and waits for a reply.

The slave cannot accept a new message until the existing message is processed and a reply sent to the master (maximum response time 250 milliseconds). The slave monitors the elapsed time between receipt of characters. If the elapsed time without a new character is $3\frac{1}{2}$ character times, the slave assumes the next character received is the start of a new message.

To allow the master to differentiate between more than one slave in a system, each slave is given a unique identity address (between 1 and 99).

A broadcast address (address zero) can be used to access all slave devices with one command. This is limited to write messages only and there is no slave acknowledgment.



Note. Modbus RTU requires 1 start bit, 8 data bits, 1 parity bit (optional) and 1 or 2 stop bits.

4.1.1 Non-volatile Memory Limitations



Note. A non-volatile memory is used to store any parameter changes made via the serial link to ensure that the information is retained during mains interruption or power-down. The memory used is rated at 10^4 write cycles per register and each register is assigned a particular parameter, e.g. Alarm trip value, Channel 1. If the number of write cycles to any particular register exceeds this value, the register's contents may not be retained.

To restrict unnecessary use of the non-volatile memory registers the memory enable/disable command is provided (Coil number 181, Section 7.1). The command can be used before parameters which do not need to be stored in the non-volatile memory, e.g. frequently changed parameters or parameters which do not have to be retained on power-down.

4.2 Modbus Function Codes

The function code field instructs the addressed slaves what function to perform. Table 4.1 shows the function codes, their meaning, and the action they initiate.

Modbus Function Code	Modbus Message Name	COMMANDER 1900 Definition
01	Read Coil Status	Read up to 16 consecutive discrete (boolean) points from a specific starting point. The COMMANDER 1900 returns zeros for points which do not contain defined data and NAKs* any request for point numbers greater than 200.
03	Read Holding Register	Read up to 8 consecutive registers from a specific starting register. The COMMANDER 1900 returns zeros from registers which do not contain defined data and NAKs any request for register numbers greater than 250.
05	Force Single Coil	Write one discrete (boolean) point. The COMMANDER 1900 NAKs this if the point is not currently writeable.
06	Preset Single Register	Write one register. The COMMANDER 1900 NAKs if the register is not currently writeable. This function code also applies to any currently applicable limits to the value before storage in the database.
08	Loopback Diagnostic Test	Echo the message, only 'Return of Query' is supported.
16	Preset Multiple Registers	Write up to 8 consecutive registers from a specified starting register. The COMMANDER 1900 NAKs if any of the registers are not currently writeable, but still carries out all the writes which are valid, applying any currently applicable limits to the value before storage in the database. This function code is only available if 'write to non-volatile memory' is disabled – see coil number 181.

*NAK = Negative Acknowledgement

Table 4.1 Modbus Function Codes

5 MODBUS FUNCTIONS

This section shows typical examples of Modbus function codes 01, 03, 05, 06, 08 and 16.

5.1 Read Coil Status – Function Code 01

5.1.1 Read Coil Status Query

This function allows the user to obtain the ON/OFF status of logic coils used to control discrete outputs from the addressed slave only. Broadcast mode is not supported with this function code. In addition to the slave address and function fields, the message requires that the information field contain the initial coil offset address to be read (starting address) and the number of locations to be interrogated must obtain status data.



Note. The coil offset address is the coil number minus one, e.g. to start at coil 31 the data start value must be set to 30 (1EH).

Example – a read coil status request to read 16 coils from slave (01) starting at coil 31 (alarm A status channel 1) is shown below.

Address	Function	Coil Start Offset High	Coil Start Offset Low	Number of Coils High	Number of Coils Low	Error Check Field (CRC-16)	
01	01	00	1E	00	10	5D	C0

5.1.2 Read Coil Status Response

The data is packed one bit for each coil (1 = ON, 0 = OFF). The response includes the slave address, function code, quantity of data characters, the data characters and error checking. The low order bit of the first character contains the first addressed coil and the remainder follow. For coil quantities that are not even multiples of eight, the last characters are filled in with zeros at high order end.

Example – the response to the read coil status query shows the following:

Alarm A status channel 1 ON
 Alarm B status channel 1 OFF
 Alarm C status channel 1 ON
 Alarm D status channel 1 OFF
 Alarm A,B,C,D status channel 2 all OFF
 Alarm A,B,C,D status channel 3 all OFF
 Alarm A,B,C,D status channel 4 all OFF

Address	Function	Byte Count	Data Coil Status 31 to 38	Data Coil Status 39 to 46	Error Check Field (CRC-16)	
01	01	02	05	00	BA	AC

5.2 Read Holding Register – Function Code 03

5.2.1 Read Holding Register Query

The Read holding registers allow the user to obtain the binary contents of holding registers in the addressed slave.



Note. The data start register must contain the offset address of the first register to be accessed, e.g. to start at register 121 the data start register must contain 120 (78H).

Broadcast mode is not allowed.

Example – a read holding register request to read 6 holding registers from slave (01) starting at holding address 121 (alarm trip A1) is shown below.

Address	Function	Register Start Offset High	Register Start Offset Low	Data Number of Registers High	Data Number of Registers Low	Error Check Field (CRC-16)	
01	03	00	78	00	06	45	D1

...5 MODBUS FUNCTIONS

5.2.2 Read Holding Register Response

The addressed slave responds with its address and function code, followed by the information field. The information field contains 1 byte describing the quantity of data bytes to be returned. The contents of each register requested (DATA) is two bytes, the first byte includes the high order bits and the second the low order bits.

Example – the response to the read holding register query shows the following:

```
Alarm trip A1 – 150
Alarm trip B1 – 50
Alarm trip C1 – 100
Alarm trip D1 – 400
Alarm trip A2 – 0
Alarm trip B2 – 0
```

Address	Function	Byte Count	Holding Register 121		Holding Register 122		Holding Register 123		Holding Register 124		Holding Register 125		Holding Register 126		Error Check Field (CRC-16)	
			High	Low	High	Low	High	Low	High	Low	High	Low	High	Low		
01	03	0C	00	96	00	32	00	64	01	90	00	00	00	00	D9	91

5.3 Force Single Coil – Function Code 05

5.3.1 Force Single Coil Query

This message forces a single coil either ON or OFF. The data value 65,280 (FF00 HEX) sets the coil ON and the value zero turns it OFF. All other values are illegal and do not affect the coil.

*** Note.** To write to a coil the coil offset address must be used, e.g. to write to coil 149, the coil address 148(94H) is transmitted.

The use of slave address zero (broadcast mode) forces all attached slaves to modify the desired coil.

Example – a force single coil request to switch ON coil address 149 (auto/manual state, channel 1) in slave 01 is shown below.

Address	Function	Coil Offset High	Coil Offset Low	Data Value High	Data Value Low	Error Check Field (CRC-16)	
01	05	00	94	FF	00	CD	D6

5.3.2 Force Single Coil Response

The response is confirmation of the query after the coil state has been altered.

Example:

Address	Function	Coil Offset High	Coil Offset Low	Data Value High	Data Value Low	Error Check Field (CRC-16)	
01	05	00	94	FF	00	CD	D6

5.4 Preset Single Register – Function Code 06

5.4.1 Preset Single Register Query

The preset single register allows the user to modify the contents of a holding register.

***** **Note.** Function codes 5, 6 and 16 are the only messages that are recognized as valid for broadcast.

Example – a preset single register request to write the value 500 to holding register address 121 (alarm trip A1) in slave 01 is shown below.

***** **Note.** To write to a register, the register’s offset address must be used, e.g. to write to register 121, the offset address 120(78H) is transmitted.

Address	Function	Register Offset High	Register Offset Low	Data Value High	Data Value Low	Error Check Field (CRC-16)	
01	06	00	78	01	F4	09	C4

5.4.2 Preset Single Register Response

The normal response to a preset single register request is to retransmit the query message after the register has been altered.

Example:

Address	Function	Register Offset High	Register Offset Low	Data Value High	Data Value Low	Error Check Field (CRC-16)	
01	06	00	78	01	F4	09	C4

5.5 Loopback Test – Function Code 08

5.5.1 Loopback Test Query

The purpose of the loopback test is to test the Modbus system, it does not affect the content of the controller. Variations in the response may indicate faults in the Modbus system. The information field contains 2 bytes for the designation of the diagnostic code followed by 2 bytes to designate the action to be taken.

Example:

Address	Function	Data Diagnostic Code High	Data Diagnostic Code Low	Data*	Data *	Error Check Field (CRC-16)	
01	08	00	00	A5	37	DA	8D

*These are considered to be the information fields for diagnostic mode.

5.5.2 Loopback Test Response

The response always echoes the query, only diagnostic code 0 (bytes 3 and 4) can be used.

Example:

Address	Function	Data Diagnostic Code High	Data Diagnostic Code Low	Data	Data	Error Check Field (CRC-16)	
01	08	00	00	A5	37	DA	8D

...5 MODBUS FUNCTIONS

5.6 Write Multiple Registers – Function Code 16

5.6.1 Write Multiple Registers Query

Holding registers existing within the controller can have their contents changed by this message (a maximum of 8 registers). When used with slave address zero (broadcast mode) all slave controllers load the selected registers with the contents specified.

Example – a write multiple register request to write the value 10 to the register address 121 and the value 100 to the register address 122 in slave 01 is shown below.

Address	Function	Register Start Offset High	Register Start Offset Low	Number of Registers	Byte Count	Holding Register 121 High	Holding Register 121 Low	Holding Register 122 High	Holding Register 122 Low	Error Check Field (CRC-16)	
01	10	00	78	00 02	04	00	0A	00	64	D4	C4

5.6.2 Write Multiple Registers Response

The response confirms slave identification, function code, starting register address and quantity only.

Example:

Address	Function	Register Start Offset High	Register Start Offset Low	Number of Registers			Error Check Field (CRC-16)	
01	10	00	78	00	02	00	10	90

6 EXCEPTION RESPONSES

The exception response codes sent by the slave are shown in Table 6.1. When a slave detects one of these errors, it sends a response message to the master consisting of slave address, function code, error code and error check fields.

Exception Response Code	Exception Response Name	Exception Response Definition
01	Illegal Function	The message function received is not an allowable action for the C1900.
02	Illegal Data Address	The address reference in the data field is not an allowable address for the C1900.
03	Illegal Data Value	The value referenced in the data field is not allowable in the addressed slave location.
07	Negative Acknowledgment	The function just requested cannot be performed.
08	Memory Parity Error	Parity check indicates an error in one or more of the characters received.

Table 6.1 Exception Response Codes

6.1 Examples

A read register request to read holding register address 251 of slave 01 (undefined address for slave, beyond address limit) is shown below.

Slave Address	Function	Register Start Offset High	Register Start Offset Low	Number of Registers High	Number of Registers Low	Error Check Field (CRC-16)	
01	03	00	FA	00	06	E5	F9

The response is an exception response sighting 'illegal data address'. To indicate that the response is a notification of an error, the most significant bit of the function code is set to 1.

Slave Address	Function	Exception Code	Error Check Field (CRC-16)
01	83	02	CO F1

7 MODBUS REGISTERS

7.1 Coils

Coil Number	Read/Write	Description	Response/Entry
Input Failure States			
011	R	Main Input	} 0 = Active 1 = Failed
012	R	Module 2	
013	R	Module 3	
014	R	Module 4	
015	R	Module 5	
A to D Converter Failure States			
021	R	Main Converter	} 0 = Active 1 = Failed
022	R	Module 2	
023	R	Module 3	
024	R	Module 4	
025	R	Module 5	
Alarm Status			
031	R	Alarm A Channel 1	} 0 = Inactive 1 = Active
032	R	Alarm B Channel 1	
033	R	Alarm C Channel 1	
034	R	Alarm D Channel 1	
035	R	Alarm A Channel 2	
036	R	Alarm B Channel 2	
037	R	Alarm C Channel 2	
038	R	Alarm D Channel 2	
039	R	Alarm A Channel 3	
040	R	Alarm B Channel 3	
041	R	Alarm C Channel 3	
042	R	Alarm D Channel 3	
043	R	Alarm A Channel 4	
044	R	Alarm B Channel 4	
045	R	Alarm C Channel 4	
046	R	Alarm D Channel 4	
Digital Input States			
051	R	Main Module Digital Input 1	} 0 = Inactive 1 = Active
052	R	Main Module Digital Input 2	
061	R	Module 2 Digital Input 1	
062	R	Module 2 Digital Input 2	
071	R	Module 3 Digital Input 1	
072	R	Module 3 Digital Input 2	
081	R	Module 4 Digital Input 1	
082	R	Module 4 Digital Input 2	
083	R	Module 4 Digital Input 3	
084	R	Module 4 Digital Input 4	
085	R	Module 4 Digital Input 5	
086	R	Module 4 Digital Input 6	
087	R	Module 4 Digital Input 7	
088	R	Module 4 Digital Input 8	
091	R	Module 5 Digital Input 1	
092	R	Module 5 Digital Input 2	
093	R	Module 5 Digital Input 3	
094	R	Module 5 Digital Input 4	
095	R	Module 5 Digital Input 5	
096	R	Module 5 Digital Input 6	
097	R	Module 5 Digital Input 7	
098	R	Module 5 Digital Input 8	

...7.1 Coils

Coil Number	Read/Write	Description	Response/Entry
Logic Equation Results			
121	R	Logic Equation 1	} 0 = Inactive 1 = Active
122	R	Logic Equation 2	
123	R	Logic Equation 3	
124	R	Logic Equation 4	
125	R	Logic Equation 5	
126	R	Logic Equation 6	
127	R	Logic Equation 7	
128	R	Logic Equation 8	
Real Time States			
131	R	Channel 1	} 0 = Inactive 1 = Active
132	R	Channel 2	
Auto/Manual States			
141	R	Manual State Channel 1	0 = Auto, 1 = Manual
142	R	Auto State Channel 1	0 = Manual, 1 = Auto
143	R	Manual State Channel 2	0 = Auto, 1 = Manual
144	R	Auto State Channel 2	0 = Manual, 1 = Auto
149	R/W	A/M State Channel 1	0 = Auto, 1 = Manual
150	R/W	A/M State Channel 2	0 = Auto, 1 = Manual
On/Off Count States			
151	R	Channel 1	} 0 = Off 1 = On
152	R	Channel 2	
Valve Open/Close Relay States			
161	R	Open Relay State Ch. 1	} 0 = De-energized 1 = Energized
162	R	Close Relay State Ch. 1	
163	R	Open Relay State Ch. 2	
164	R	Close Relay State Ch. 2	
171*	R	Event Status (C1951, C1952, C1953 Pasteurizer versions only)	0 = Divert, 1 = Forward
181	R/W	MODBUS Save Modbus Writes to Non-Volatile Memory	0 = Not Saved, 1 = Saved

...7 MODBUS REGISTERS

7.2 Holding Registers

Register Number	Read/Write	Description	Response/Entry
		Analog Inputs	
011	R	Process Variable 1	} In Engineering Units in Range -9999 to +9999
012	R	Process Variable 2	
013	R	Process Variable 3	
014	R	Process Variable 4	
015	R	Process Variable 1 Failure State	} 0 = Input Active 1 = Input Failed 2 = A to D Failed 3 = Input and A to D Failed
016	R	Process Variable 2 Failure State	
017	R	Process Variable 3 Failure State	
018	R	Process Variable 4 Failure State	
		Number of Decimal Points	
019	R	Process Variable 1 Value	} 0 to 3 Decimal Places
020	R	Process Variable 2 Value	
021	R	Process Variable 3 Value	
022	R	Process Variable 4 Value	
		Input Values	
031	R	Main Input	} In Engineering Units in Range -9999 to +9999
032	R	Module 2	
033	R	Module 3	
034	R	Module 4	
035	R	Module 5	
		Engineering Ranges	
041	R	Input 1 Decimal Point Position	} 0 to 3 Decimal Places
042	R	Input 2 Decimal Point Position	
043	R	Input 3 Decimal Point Position	
044	R	Input 4 Decimal Point Position	
045	R	Input 5 Decimal Point Position	

7.3 Controller Settings/Outputs

Register Number	Read/Write	Description	Response/Entry
Controller Settings/Outputs Channel 1			
051	R	Process Variable 1	-9999 to +9999
052	R/W	Control Set Point	-9999 to +9999
053	R/W	Control Output (write in manual mode)	0 to 1000 Representing (0.0.to 100.0%)
054	R	Position Feedback 1	0 to 1000 Representing (0.0.to 100.0%)
055	R	Position Feedback 1 Failure State	0 = Input Active 1 = Input Failed 2 = A to D Failed 3 = Input and A to D Failed
056	R/W	On/Off Hysteresis Value	0 to 1000 Representing (0.0.to 100.0%)
057	R/W	Cycle-Time Heat Control	10 to 3000 (1.0 to 300.0 Seconds)
058	R/W	Proportional Band (Heat) Control	1 to 9999 (0.1 to 999.9%)
059	R/W	Integral Value (Heat) Control	0 = OFF, 1 to 7200 Seconds
060	R/W	Manual Reset (Heat) Control	0 to 1000 (0.0 to 100.0%)
061	R/W	Derivative Action	1 to 9999 (0.1 to 999.9 Seconds)
062	R/W	Approach Band	1 to 30 (0.1 to 3.0)
063	R/W	Heat Output (write manual mode only)	0 to 1000 (0.0 to 100.0%)
064	R/W	Cool Output (write manual mode only)	0 to 1000 (0.0 to 100.0%)
065	R/W	Proportional Band Cool Control	1 to 9999 (0.1 to 999.9%)
066	R/W	Integral Value Cool Control	0 = OFF, 1 to 7200 Seconds
067	R/W	Manual Reset Cool Control	0 to 1000 (0.0 to 100.0%)
068	R/W	Cycle-Time Cool Control	10 to 3000 (1.0 to 300.0 Seconds)
069	R/W	Crossover Band	0 to 1000 (0.0 to 100.0%)
070	R/W	Transition Band	0 to 1000 (0.0 to 100.0%)
Controller Settings/Outputs Channel 2			
071	R	Process Variable 2	-9999 to +9999
072	R/W	Control Set Point	-9999 to +9999
073	R/W	Control Output (write in manual mode)	0 to 1000 Representing (0.0.to 100.0%)
074	R	Position Feedback 2	0 to 1000 Representing (0.0.to 100.0%)
075	R	Position Feedback 2 Failure State	0 = Input Active 1 = Input Failed 2 = A to D Failed 3 = Input and A to D Failed
076	R/W	On/Off Hysteresis Value	0 to 1000 Representing (0.0.to 100.0%)
077	R/W	Cycle-Time Heat Control	10 to 3000 (1.0 to 300.0 Seconds)
078	R/W	Proportional Band (Heat) Control	1 to 9999 (0.1 to 999.9%)
079	R/W	Integral Value (Heat) Control	0 = OFF, 1 to 7200 Seconds
080	R/W	Manual Reset (Heat) Control	0 to 1000 (0.0 to 100.0%)
081	R/W	Derivative Action	1 to 9999 (0.1 to 999.9 Seconds)
082	R/W	Approach Band	1 to 30 (0.1 to 3.0)
083	R/W	Heat Output (write manual mode only)	0 to 1000 (0.0 to 100.0%)
084	R/W	Cool Output (write manual mode only)	0 to 1000 (0.0 to 100.0%)
085	R/W	Proportional Band Cool Control	1 to 9999 (0.1 to 999.9%)
086	R/W	Integral Value Cool Control	0 = OFF, 1 to 7200 Seconds
087	R/W	Manual Reset Cool Control	0 to 1000 (0.0 to 100.0%)
088	R/W	Cycle-Time Cool Control	10 to 3000 (1.0 to 300.0 Seconds)
089	R/W	Crossover Band	0 to 1000 (0.0 to 100.0%)
090	R/W	Transition Band	0 to 1000 (0.0 to 100.0%)

...7 MODBUS REGISTERS

7.4 Set Points

Register Number	Read/Write	Description	Response/Entry
Set Points Channel 1			
101	R/W	Local Set Point	-9999 to +9999
102	R/W	Dual Set Point	-9999 to +9999
103	R	Remote Set Point (without Ratio/Bias)	-9999 to +9999
104	R	Remote Set Point (with Ratio/Bias)	-9999 to +9999
105	R	Remote Set Point Failure State	Refer to Process Variable Failure States
107	R/W	Set Point Selection	0 = Local, 1 = 2nd Set Point
Set Points Channel 2			
111	R/W	Local Set Point	-9999 to +9999
112	R/W	Dual Set Point	-9999 to +9999
113	R	Remote Set Point (without Ratio/Bias)	-9999 to +9999
114	R	Remote Set Point (with Ratio/Bias)	-9999 to +9999
115	R	Cascade Set Point	-9999 to +9999
116	R	Remote Set Point Failure State	Refer to Process Variable Failure States
117	R/W	Set Point Selection	0 = Local, 1 = 2nd Set Point

7.5 Alarm Settings

Register Number	Read/Write	Description	Response/Entry
Alarm Settings			
121	R/W	Alarm A Trip Value Channel 1	-9999 to +9999 High/Low Process Limit 5 to 5000 (0.5 to 500.0%) Fast/Slow Rate Alarm Limit
122	R/W	Alarm B Trip Value Channel 1	
123	R/W	Alarm C Trip Value Channel 1	
124	R/W	Alarm D Trip Value Channel 1	
125	R/W	Alarm A Trip Value Channel 2	
126	R/W	Alarm B Trip Value Channel 2	
127	R/W	Alarm C Trip Value Channel 2	
128	R/W	Alarm D Trip Value Channel 2	
129	R/W	Alarm A Trip Value Channel 3	
130	R/W	Alarm B Trip Value Channel 3	
131	R/W	Alarm C Trip Value Channel 3	
132	R/W	Alarm D Trip Value Channel 3	
133	R/W	Alarm A Trip Value Channel 4	
134	R/W	Alarm B Trip Value Channel 4	
135	R/W	Alarm C Trip Value Channel 4	
136	R/W	Alarm D Trip Value Channel 4	
141	R	Alarm A Type Channel 1	0 = Alarm Off 1 = High Process 2 = Low Process 3 = High Output 4 = Low Output 5 = High Deviation 6 = Low Deviation 7 = Fast Rate 8 = Slow Rate
142	R	Alarm B Type Channel 1	
143	R	Alarm C Type Channel 1	
144	R	Alarm D Type Channel 1	
145	R	Alarm A Type Channel 2	
146	R	Alarm B Type Channel 2	
147	R	Alarm C Type Channel 2	
148	R	Alarm D Type Channel 2	
149	R	Alarm A Type Channel 3	
150	R	Alarm B Type Channel 3	
151	R	Alarm C Type Channel 3	
152	R	Alarm D Type Channel 3	
153	R	Alarm A Type Channel 4	
154	R	Alarm B Type Channel 4	
155	R	Alarm C Type Channel 4	
156	R	Alarm D Type Channel 4	

7.6 Chart Settings

Register Number	Read/Write	Description	Response/Entry
161 162	R/W R	Chart Settings Chart Rotation Time Pen Lift Status	1 to 167 Hrs, 168 = 7 Days to 193 = 32 Day 0 = Pen recording on chart 1 = Pen lifting off chart

7.7 Ramp/Soak Settings

Register Number	Read/Write	Description	Response/Entry
171 172 173 174 175	W W W W W	Ramp/Soak Settings Channel 1 Ramp Soak Run Command Ramp Soak Hold Command Ramp Soak Skip Forward Command Ramp Soak Skip Backward Command Ramp Soak Reset Command	1 = Run Profile 1 = Hold Profile 1 = Skip Forward 1 = Skip Backward 1 = Reset Profile
176	R	Profile Status	0 = Off 1 = Ramp 2 = Soak 3 = Retort Ramp 4 = Operator Hold 5 = Holdback Hold 6 = Retort Hold 7 = End
177 178 179	W R R/W	Extend Soak Time Command Remaining Segment Time Selected Program	2 = Extend Soak Time 0 to 9999 (0.0 to 999.9 Hours or Minutes) Select Channel 1 Program to Run, 1 to 10
181 182 183 184 185	W W W W W	Ramp/Soak Settings Channel 2 Ramp Soak Run Command Ramp Soak Hold Command Ramp Soak Skip Forward Command Ramp Soak Skip backward Command Ramp Soak Reset Segment Command	1 = Run Profile 1 = Hold Profile 1 = Skip Forward 1 = Skip Backward 1 = Reset Profile
186	R	Profile Status	0 = Off 1 = Ramp 2 = Soak 3 = Retort Ramp 4 = Operator Hold 5 = Holdback Hold 6 = Retort Hold 7 = End
187 188 189	W R R/W	Extend Soak Time Command Remaining Segment Time Selected Program	2 = Extend Soak Time 0 to 9999 (0.0 to 999.9 Hours or Minutes) Select Channel 1 Program to Run, 1 to 10

...7 MODBUS REGISTERS

7.8 Totalizer Settings

Register Number	Read/Write	Description	Response/Entry	
191	R	Predetermined Value Channel 1* High Word	The Limit for High Word:Low Word linked together is 0 to 99,999,999	
192	R	Low Word		
193	R	Preset Value Channel 1* High Word		
194	R	Low Word		
195	R	Front-panel Totalizer Value Ch. 1* High Word		
196	R	Low Word		
197	R	Secure Totalizer Value Ch. 1* High Word		
198	R	Low Word		
199	R/W	Totalizer Stop/Go Command		0 = Stop, 1 = Go
200	W	Totalizer Front-Panel Reset Command		1 = Reset
201	R	Predetermined Value Ch. 2* High Word	The Limit for High Word:Low Word linked together is 0 to 99,999,999	
202	R	Low Word		
203	R	Preset Value Channel 2* High Word		
204	R	Low Word		
205	R	Front-panel Totalizer Value Ch. 2* High Word		
206	R	Low Word		
207	R	Secure Totalizer Value Ch. 2* High Word		
208	R	Low Word		
209	R/W	Totalizer Stop/Go Command		0 = Stop, 1 = Go
210	W	Totalizer Front-Panel Reset Command		1 = Reset
211	R	Predetermined Value Channel 3* High Word	The Limit for High Word:Low Word linked together is 0 to 99,999,999	
212	R	Low Word		
213	R	Preset Value Channel 3* High Word		
214	R	Low Word		
215	R	Front-panel Totalizer Value Ch. 3* High Word		
216	R	Low Word		
217	R	Secure Totalizer Value Channel 3* High Word		
218	R	Low Word		
219	R/W	Totalizer Stop/Go Command		0 = Stop, 1 = Go
220	W	Totalizer Front-Panel Reset Command		1 = Reset
221	R	Predetermined Value Channel 4* High Word	The Limit for High Word:Low Word linked together is 0 to 99,999,999	
222	R	Low Word		
223	R	Preset Value Channel 4* High Word		
224	R	Low Word		
225	R	Front-panel Totalizer Value Ch. 4* High Word		
226	R	Low Word		
227	R	Secure Totalizer Value Channel 4* High Word		
228	R	Low Word		
229	R/W	Totalizer Stop/Go Command		0 = Stop, 1 = Go
230	W	Totalizer Front-Panel Reset Command		1 = Reset

*These values are a combination of the High Word and Low Word.

7.9 Holding Registers – Pasteurizer Versions Only

Register Number	Read/Write	Description	Response/Entry
91	R	Second RTD	-9999 to +9999
92	R	RTD Deviation	0.0 to 100.0
93	R	Cold Set Point (C1953 Only)	-999.9 to +999.9
94	R	Hot Water Temperature (C1952/3 Only)	-9999 to +9999
95	R	Hot Product Temperature	-9999 to +9999
96	R	Cold Product Temperature	-9999 to +9999
Single or Multiple Divert 1			
231	R/W	Divert Temperature 1	-999.9 to +999.9
232	R/W	Multiple Divert/ Hot Water Set Point 1	-999.9 to +999.9
Multiple Divert 2			
233	R/W	Divert Temperature 2	-999.9 to +999.9
234	R/W	Multiple Divert/ Hot Water Set Point 2	-999.9 to +999.9
Multiple Divert 3			
235	R/W	Divert Temperature 3	-999.9 to +999.9
236	R/W	Multiple Divert/ Hot Water Set Point 3	-999.9 to +999.9
Multiple Divert 4			
237	R/W	Divert Temperature 4	-999.9 to +999.9
238	R/W	Multiple Divert/ Hot Water Set Point 4	-999.9 to +999.9
Multiple Divert 5			
239	R/W	Divert Temperature 5	-999.9 to +999.9
240	R/W	Multiple Divert/ Hot Water Set Point 5	-999.9 to +999.9
Multiple Divert 6			
241	R/W	Divert Temperature 6	-999.9 to +999.9
242	R/W	Multiple Divert/ Hot Water Set Point 6	-999.9 to +999.9
Multiple Divert 7			
243	R/W	Divert Temperature 7	-999.9 to +999.9
244	R/W	Multiple Divert/ Hot Water Set Point 7	-999.9 to +999.9
Multiple Divert 8			
245	R/W	Divert Temperature 8	-999.9 to +999.9
246	R/W	Multiple Divert/ Hot Water Set Point 8	-999.9 to +999.9

NOTES

PRODUCTS & CUSTOMER SUPPORT

A Comprehensive Instrumentation Range

Analytical Instrumentation

- **Transmitters**
On-line pH, conductivity, and dissolved oxygen transmitters and associated sensing systems.
- **Sensors**
pH, redox, selective ion, conductivity and dissolved oxygen.
- **Laboratory Instrumentation**
pH and dissolved oxygen meters and associated sensors.
- **Water Analyzers**
For water quality monitoring in environmental, power generation and general industrial applications including: pH, conductivity, ammonia, nitrate, phosphate, silica, sodium, chloride, fluoride, dissolved oxygen and hydrazine.
- **Gas Analyzers**
Zirconia, katharometers, hydrogen purity and purge-gas monitors, thermal conductivity.

Controllers & Recorders

- **Controllers**
Digital display, electronic, pneumatic. Discrete single-loop and multi-loop controllers which can be linked to a common display station, process computer or personal computer.
- **Recorders**
Circular and strip-chart types (single and multi-point) for temperature, pressure, flow and many other process measurements.

Electronic Transmitters

- **Smart & Analog Transmitters**
For draft, differential, gauge and absolute pressure measurement. Also, liquid level and temperature.
- **I to P Converters and Field Indicators**

Flow Metering

- **Magnetic Flowmeters**
Electromagnetic, insertion type probes and watermeters.
- **Turbine Flowmeters**
- **Wedge Flow Elements**
- **Mass Flow Meters**
Transmitters, sensors, controllers and batch/display units.

Level Control

- **Submersible, Capacitance & Conductivity.**

Pneumatic Instrumentation

- **Transmitters**
- **Indicating Controllers**
- **Recording Controllers**

Customer Support

ABB Instrumentation provides a comprehensive after sales service via a Worldwide Service Organization. Contact one of the following offices for details on your nearest Service and Repair Centre.

United Kingdom

ABB Instrumentation Limited
Tel: +44 (0)1480 475321
Fax: +44 (0)1480 470787

United States of America

ABB Instrumentation Inc.
Tel: +1 716 292 6050
Fax: +1 716 273 6207

Italy

ABB Instrumentation
Tel: +39 (0) 344 58111
Fax: +39 (0) 344 58278

Client Warranty

Prior to installation, the equipment referred to in this manual must be stored in a clean, dry environment, in accordance with the Company's published specification. Periodic checks must be made on the equipment's condition.

In the event of a failure under warranty, the following documentation must be provided as substantiation:

1. A listing evidencing process operation and alarm logs at time of failure.
2. Copies of operating and maintenance records relating to the alleged faulty unit.



The Company's policy is one of continuous product improvement and the right is reserved to modify the information contained herein without notice.

© ABB 1999

Printed in UK (4.99)

ABB Instrumentation Ltd

St. Neots
Cambs.
England, PE19 3EU
Tel: +44 (0) 1480 475321
Fax: +44 (0) 1480 217948

ABB Instrumentation Inc.

PO Box 20550, Rochester
New York 14602-0550
USA
Tel: +1 716 292 6050
Fax: +1 716 273 6207

ABB Instrumentation

22016 Lenno
Como
Italy
Tel: +39 (0) 344 58111
Fax: +39 (0) 344 58278