



# ABB

## The Company

We are an established world force in the design and manufacture of instrumentation for industrial process control, flow measurement, gas and liquid analysis and environmental applications.

As a part of ABB, a world leader in process automation technology, we offer customers application expertise, service and support worldwide.

We are committed to teamwork, high quality manufacturing, advanced technology and unrivalled service and support.

The quality, accuracy and performance of the Company's products result from over 100 years experience, combined with a continuous program of innovative design and development to incorporate the latest technology.

The UKAS Calibration Laboratory No. 0255 is just one of the ten flow calibration plants operated by the Company and is indicative of our dedication to quality and accuracy.

EN ISO 9001:2000



Cert. No. Q 05907

EN 29001 (ISO 9001)



Lenno, Italy – Cert. No. 9/90A

Stonehouse, U.K.



## Electrical Safety

This equipment complies with the requirements of CEI/IEC 61010-1:2001-2 'Safety Requirements for Electrical Equipment for Measurement, Control and Laboratory Use'. If the equipment is used in a manner NOT specified by the Company, the protection provided by the equipment may be impaired.

## Symbols

One or more of the following symbols may appear on the equipment labelling:

	<b>Warning</b> – Refer to the manual for instructions		Direct current supply only
	<b>Caution</b> – Risk of electric shock		Alternating current supply only
	Protective earth (ground) terminal		Both direct and alternating current supply
	Earth (ground) terminal		The equipment is protected through double insulation

Information in this manual is intended only to assist our customers in the efficient operation of our equipment. Use of this manual for any other purpose is specifically prohibited and its contents are not to be reproduced in full or part without prior approval of the Technical Publications Department.

### Health and Safety

To ensure that our products are safe and without risk to health, the following points must be noted:

1. The relevant sections of these instructions must be read carefully before proceeding.
2. Warning labels on containers and packages must be observed.
3. Installation, operation, maintenance and servicing must only be carried out by suitably trained personnel and in accordance with the information given.
4. Normal safety precautions must be taken to avoid the possibility of an accident occurring when operating in conditions of high pressure and/or temperature.
5. Chemicals must be stored away from heat, protected from temperature extremes and powders kept dry. Normal safe handling procedures must be used.
6. When disposing of chemicals ensure that no two chemicals are mixed.

Safety advice concerning the use of the equipment described in this manual or any relevant hazard data sheets (where applicable) may be obtained from the Company address on the back cover, together with servicing and spares information.

## Contents

<b>1</b>	<b>Introduction .....</b>	<b>2</b>	<b>6</b>	<b>Exception Responses .....</b>	<b>13</b>
			6.1	Examples .....	13
<b>2</b>	<b>Electrical Installation .....</b>	<b>3</b>	<b>7</b>	<b>Modbus Registers .....</b>	<b>14</b>
2.1	Selection of Serial Communication Adaptors for Personal Computers .....	3	7.1	Coils .....	14
2.2	Recommended OPTO22 Boards .....	3	7.2	Holding Registers .....	16
2.3	Pull-up and Pull-down Resistors .....	3	7.3	Alarm Settings .....	17
2.4	Termination Resistors .....	5	7.4	Chart Settings .....	18
2.5	RS485/422 Standard .....	5	7.5	Totalizer Settings .....	19
2.6	Serial Connections .....	6			
<b>3</b>	<b>Modbus Configuration .....</b>	<b>7</b>			
3.1	Modbus Configuration .....	7			
<b>4</b>	<b>Modbus Protocol .....</b>	<b>8</b>			
4.1	Introduction to Modbus Protocol .....	8			
4.2	Modbus Function Codes .....	8			
<b>5</b>	<b>Modbus Functions .....</b>	<b>9</b>			
5.1	Read Coil Status – Function Code 01 .....	9			
5.1.1	Read Coil Status Query .....	9			
5.1.2	Read Coil Status Response .....	9			
5.2	Read Holding Register – Function Code 03 .....	9			
5.2.1	Read Holding Register Query .....	9			
5.2.2	Read Holding Register Response .....	10			
5.3	Force Single Coil – Function Code 05 .....	10			
5.3.1	Force Single Coil Query .....	10			
5.3.2	Force Single Coil Response .....	10			
5.4	Preset Single Register – Function Code 06 .....	11			
5.4.1	Preset Single Register Query .....	11			
5.4.2	Preset Single Register Response .....	11			
5.5	Loopback Test – Function Code 08 .....	11			
5.5.1	Loopback Test Query .....	11			
5.5.2	Loopback Test Response .....	11			
5.6	Write Multiple Registers – Function Code 16 .....	12			
5.6.1	Write Multiple Registers Query .....	12			
5.6.2	Write Multiple Registers Response .....	12			
				<b>Notes</b>	<b>20</b>

## 1 Introduction

The C1300 can be enhanced by the addition of a serial data communication option for use with SCADA systems with:

- RS422/485 communication standard
- Modbus® protocol – for master (host computer) to slave (C1300) system
- Isolated (500V) from rest of instrument
- 3- and 5-wire communication supported
- Baud rate – from 1200 to 9600
- Parity-checking – of message available

This supplement describes how to connect and configure the C1300 for operation on a Modbus network and must be read in conjunction with the *User Guide (IM/C1300)*.

## 2 Electrical Installation

### 2.1 Selection of Serial Communication Adaptors for Personal Computers

**Note.**

- An RS422/485 communication board is required in the host PC.
- Observe the limitations outlined in the Installation Guide – the maximum serial data transmission line length for both RS422 and RS485 systems is 1200m (3,937 ft).

An RS422/485 communications adaptor is required for serial links. Ensure that the card used has galvanic isolation to protect the computer from lightning damage and increase its immunity to noise pick-up.

### 2.2 Recommended OPTO22 Boards

The following OPTO22 boards are recommended for use with the C1300:

Part No.	Computer Type
AC24 AT	AT Bus IBM® PC compatible
AC34	Microchannel IBM® PC

### 2.3 Pull-up and Pull-down Resistors – Figs. 2.1 and 2.2

To prevent false triggering of the slave (C1300) by the presence of noise when the master (host computer) is inactive, 1.8kΩ pull-up and pull-down resistors must be fitted to the RS422/485 adaptor card – see Figs. 2.1 and 2.2.

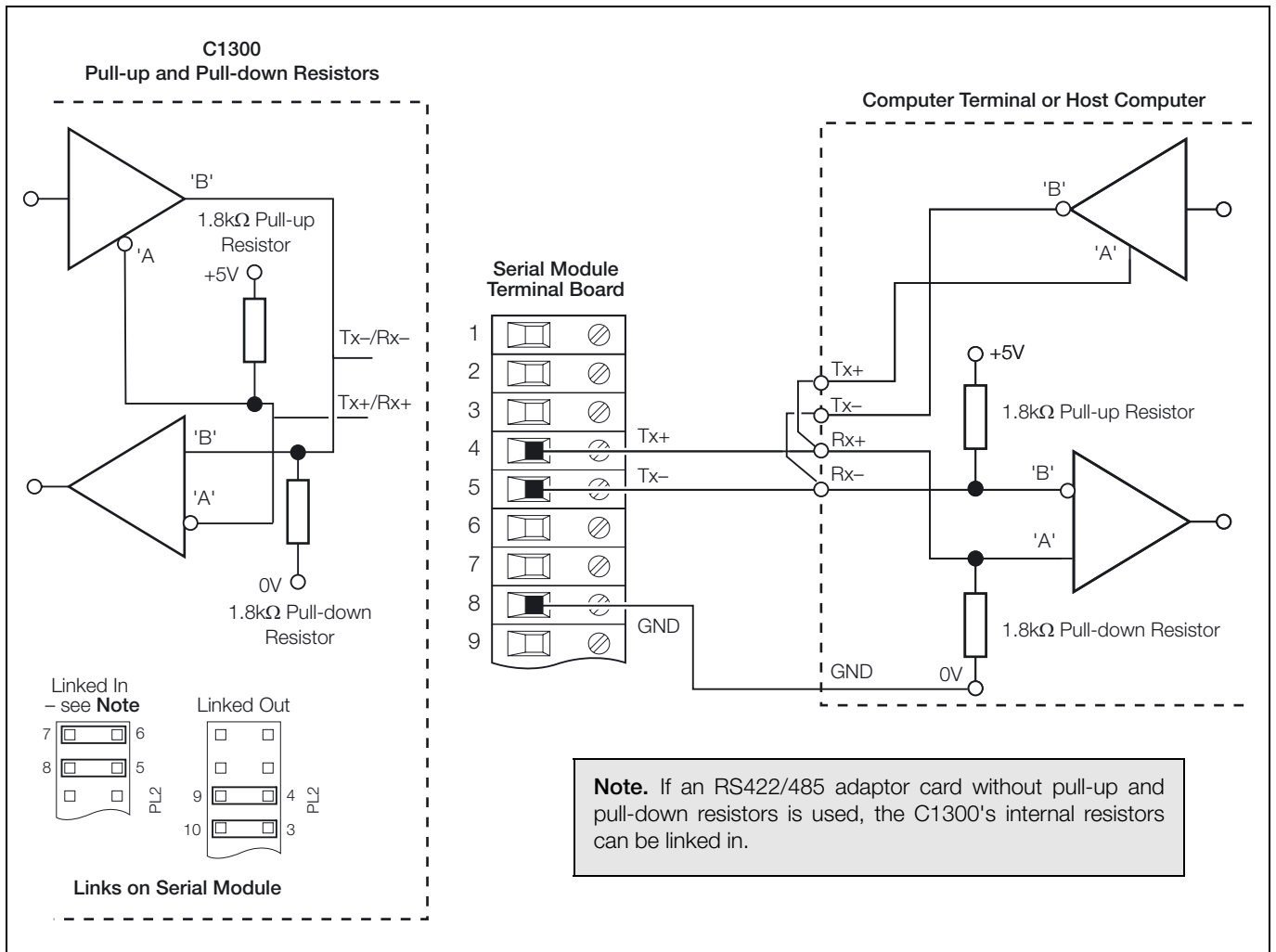
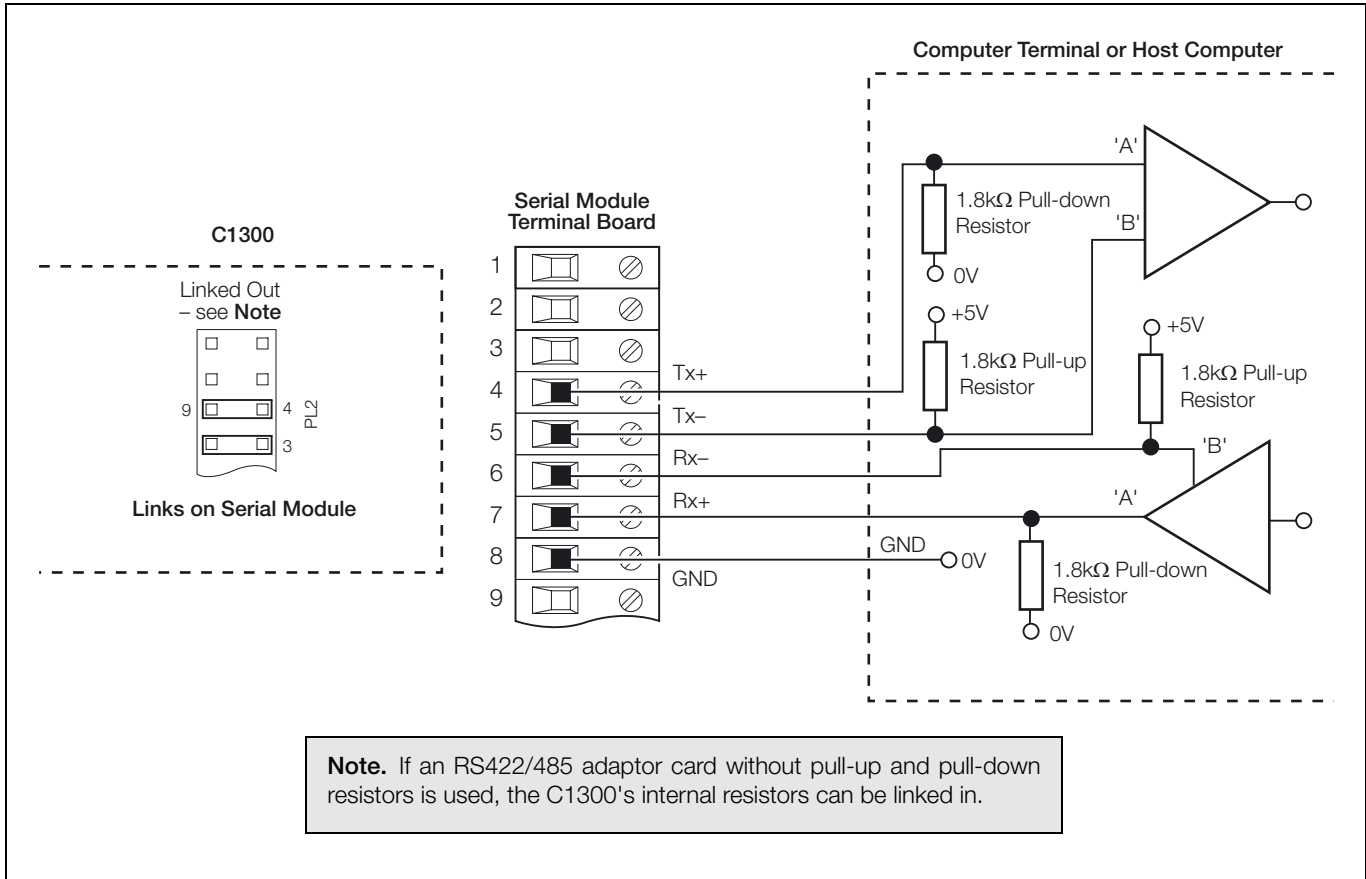

Fig. 2.1 Pull-up and Pull-down Resistors (3-wire Operation)



**Note.** If an RS422/485 adaptor card without pull-up and pull-down resistors is used, the C1300's internal resistors can be linked in.

Fig. 2.2 Pull-up and Pull-down Resistors (5-wire Operation)

### 2.4 Termination Resistors – Fig. 2.3

For long transmission lines, termination resistors are required on the last slave in the chain and the host computer/computer terminal – see Fig. 2.3. Under normal operating conditions the resistors are required at the receive inputs only. For 2-wire operation the slave termination resistor is fitted to the serial module terminal board – see Fig. 2.3A. For 4-wire operation the slave termination resistor is selected using plug-in links on the serial module – see Fig. 2.3B.

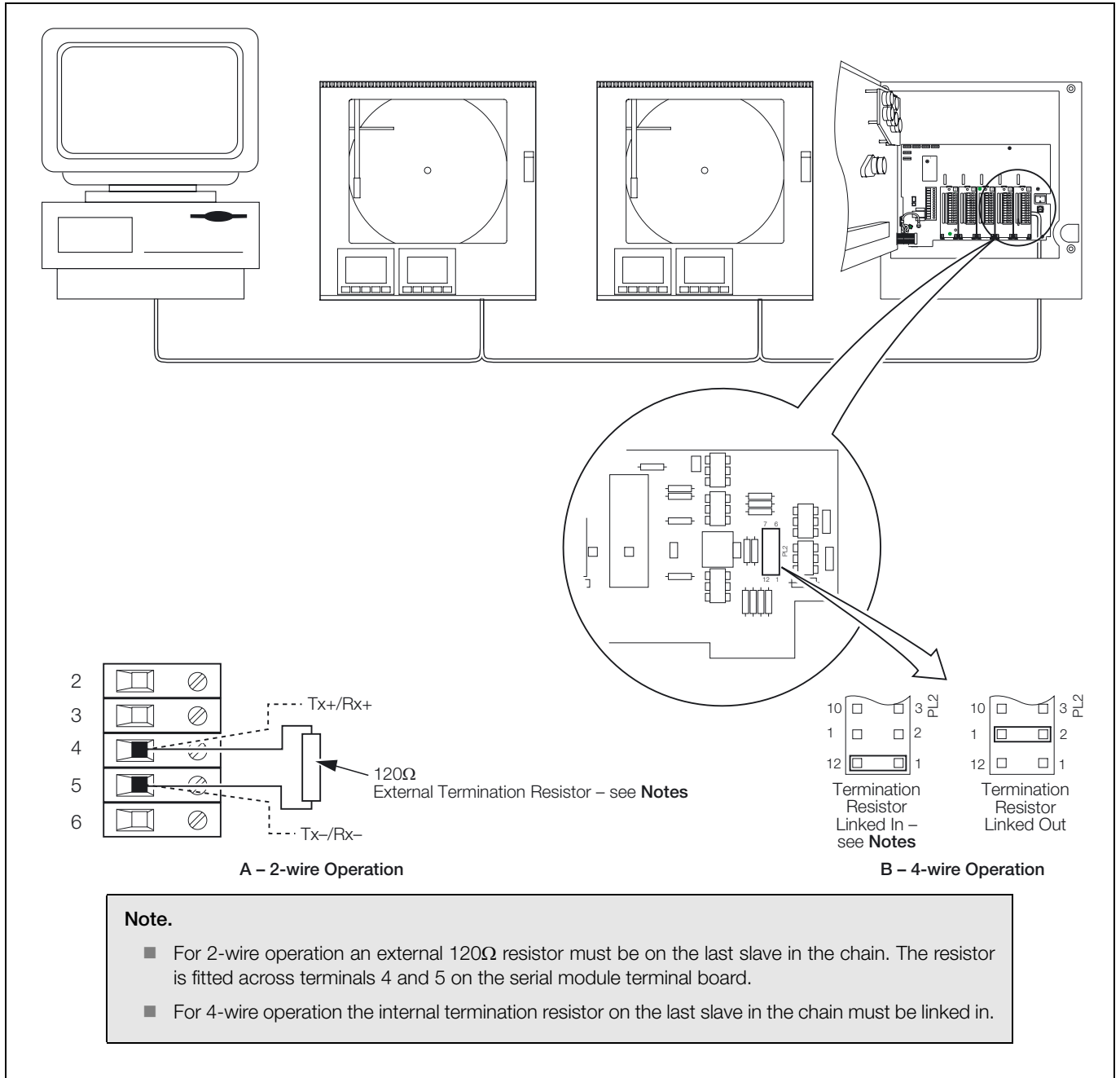

Fig. 2.3 Slave Termination Resistors

### 2.5 RS485/422 Standard

The RS485 standard quotes connection of thirty two slaves maximum, to any single driver (computer terminal or host computer); the RS422 standard quotes connection of up to ten slaves. However, these numbers can be increased if the driver's serial port permits.

2.6 Serial Connections – Fig. 2.4

Note.

- Up to **10 slaves** can be connected to a single **RS422** adaptor card on a PC.
- Up to **32 slaves** can be connected to a single **RS485** adaptor card on a PC.
- The maximum serial data transmission line length for both **RS422** and **RS485** systems is 1200m (3,937 ft).

All connections, apart from those for serial data communication, are made as shown in Section 5 of the User Guide (IM/C1300).

Make serial data connections as shown in Fig. 2.4. The type of cable used is dependent on the cable length:

- Up to 6m (20 ft)** – standard screened or twisted pair cable
- Up to 300m (984 ft)** – twin twisted pair with overall foil screen and an integral drain wire, e.g. Belden 9502 or equivalent
- Up to 1200m (3,937 ft)** – twin twisted pair with separate foil screens and integral drain wires for each pair, e.g. Belden 9729 or equivalent

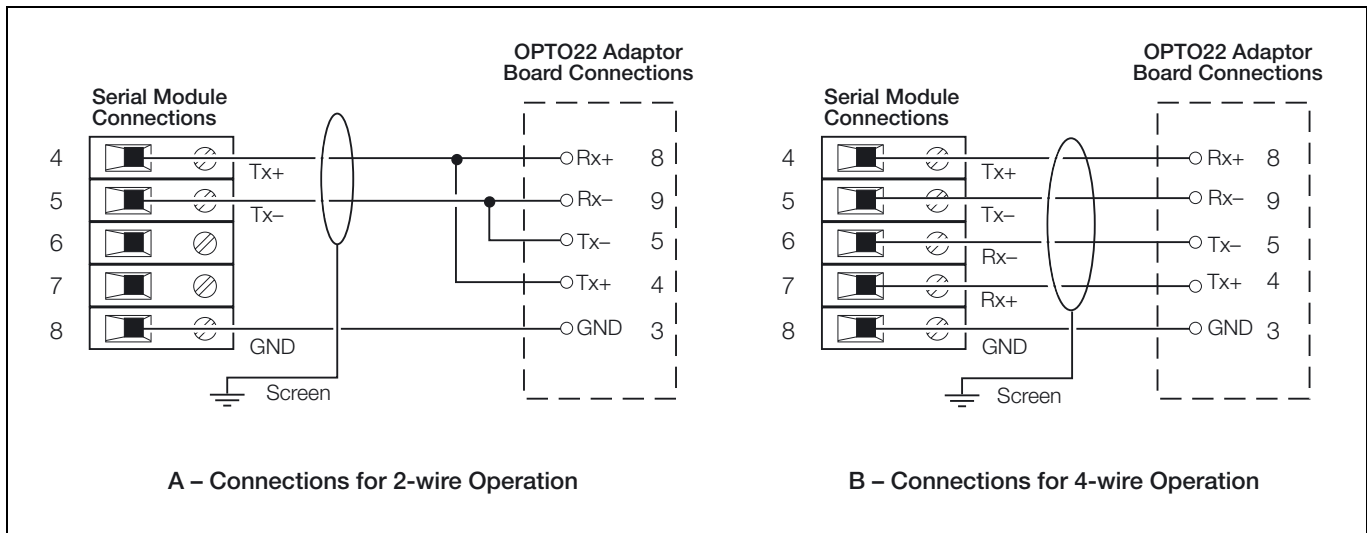

Fig. 2.4 Serial Module Connections

C1300 Serial Module Terminal Board		OPTO22 Board Pin Identification	
Terminal Number	Connections	Part Number AC24 AT & AC34	Connections
4	TX+	4	TX+
		8	RX+
5	TX-	5	TX-
		9	RX-
8	GND	3	GND

Table 2.1 Terminal and Pin Identification for 2-wire Operation

C1300 Serial Module Terminal Board		OPTO22 Board Pin Identification	
Terminal Number	Connections	Part Number AC24 AT & AC34	Connections
4	TX+	8	RX+
5	TX-	9	RX-
6	RX-	5	TX-
7	RX+	4	TX+
8	GND	3	GND

Table 2.2 Terminal and Pin Identification for 4-wire Operation



## 3 Modbus Configuration

### 3.1 Modbus Configuration

**Note.**

- Programmable for 2- or 4-wire connections.
- Programmable baud rate (1200 to 9600 baud).
- Odd or even parity.

All other instrument configuration procedure is detailed in the *User Guide (IM/C1300)*.

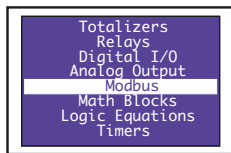

#### Modbus Configuration

Press the  key to open the **Main Menu**.

Highlight **Modbus**.

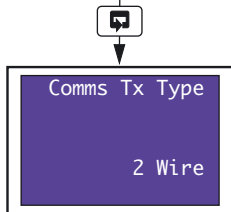

#### Communications Transmission Type

Select the required number of transmission wires, 2-wire or 4-wire.

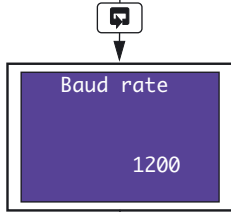

#### Baud Rate

Select the transmission rate required (1200 slowest, 9600 fastest).

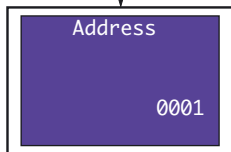

#### Address

Assign the instrument an address between 1 and 99.

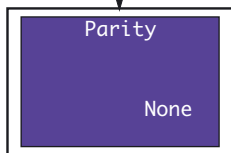

#### Parity

Select the appropriate parity to match the computer terminal or host computer.

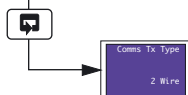

Return to top of page.

## 4 Modbus Protocol

### Note.

- The C1300 operates as a Modbus, Remote Terminal Unit (RTU) slave.
- Parity checking – used to detect transmission errors in individual characters.
- Cyclic redundancy checking – used to detect errors in the master messages and slave responses.
- Non-volatile memory save command.

### 4.1 Introduction to Modbus Protocol

Modbus communication is based on a master and a slave arrangement. The master sends a message to one slave at a time and waits for a reply.

The slave cannot accept a new message until the existing message is processed and a reply sent to the master (maximum response time 250 milliseconds). The slave monitors the elapsed time between receipt of characters. If the elapsed time without a new character is 3½ character times, the slave assumes the next character received is the start of a new message.

To allow the master to differentiate between more than one slave in a system, each slave is given a unique identity address (between 1 and 99).

A broadcast address (address zero) can be used to access all slave devices with one command. This is limited to write messages only and there is no slave acknowledgment.

**Note.** Modbus RTU requires 1 start bit, 8 data bits, 1 parity bit (optional) and 1 or 2 stop bits.

### 4.2 Modbus Function Codes

The function code field instructs the addressed slaves what function to perform. Table 4.1 shows the function codes, their meaning, and the action they initiate.

Modbus Function Code	Modbus Message Name	C1300 Definition
01	Read Coil Status	Read up to 16 consecutive discrete (boolean) points from a specific starting point. The C1300 returns zeros for points which do not contain defined data and NAKs* any request for point numbers greater than 200.
03	Read Holding Register	Read up to 8 consecutive registers from a specific starting register. The C1300 returns zeros from registers which do not contain defined data and NAKs* any request for register numbers greater than 250.
05	Force Single Coil	Write one discrete (boolean) point. The C1300 NAKs* this if the point is not currently writeable.
06	Preset Single Register	Write one register. The C1300 NAKs* if the register is not currently writeable. This function code also applies to any currently applicable limits to the value before storage in the database.
08	Loopback Diagnostic Test	Echo the message; only 'Return of Query' is supported.
16	Preset Multiple Registers	Write up to 8 consecutive registers from a specified starting register. The C1300 NAKs* if any of the registers are not currently writeable, but still carries out all the writes which are valid, applying any currently applicable limits to the value before storage in the database.

\*NAK = Negative Acknowledgement

Table 4.1 Modbus Function Codes

## 5 Modbus Functions

This section shows typical examples of Modbus function codes 01, 03, 05, 06, 08 and 16.

### 5.1 Read Coil Status – Function Code 01

#### 5.1.1 Read Coil Status Query

This function allows the user to obtain the ON/OFF status of logic coils used to control discrete outputs from the addressed slave only. Broadcast mode is not supported with this function code. In addition to the slave address and function fields, the message requires that the information field contain the initial coil offset address to be read (starting address) and the number of locations to be interrogated must obtain status data.

**Note.** The coil offset address is the coil number minus one, e.g. to start at coil 31 the data start value must be set to 30 (1EH).

**Example** – a read coil status request to read 16 coils from slave (01) starting at coil 31 (alarm A status channel 1) is shown below.

Address	Function	Coil Start Offset		Number of Coils		Error Check Field	(CRC-16)
		High	Low	High	Low		
01	01	00	1E	00	10	5D	C0

#### 5.1.2 Read Coil Status Response

The data is packed one bit for each coil (1 = ON, 0 = OFF). The response includes the slave address, function code, quantity of data characters, the data characters and error checking. The low order bit of the first character contains the first addressed coil and the remainder follow. For coil quantities that are not even multiples of eight, the last characters are filled in with zeros at high order end.

**Example** – the response to the read coil status query shows the following:

Alarm A status channel 1 ON  
 Alarm B status channel 1 OFF  
 Alarm C status channel 1 ON  
 Alarm D status channel 1 OFF  
 Alarm A,B,C,D status channel 2 all OFF  
 Alarm A,B,C,D status channel 3 all OFF  
 Alarm A,B,C,D status channel 4 all OFF

Address	Function	Byte Count	Data Coil Status 31 to 38	Data Coil Status 39 to 46	Error Check Field	(CRC-16)
01	01	02	05	00	BA	AC

### 5.2 Read Holding Register – Function Code 03

#### 5.2.1 Read Holding Register Query

The Read holding registers allow the user to obtain the binary contents of holding registers in the addressed slave.

**Note.** The data start register must contain the offset address of the first register to be accessed, e.g. to start at register 121 the data start register must contain 120 (78H).

Broadcast mode is not allowed.

**Example** – a read holding register request to read 6 holding registers from slave (01) starting at holding address 121 (alarm trip A1) is shown below.

Address	Function	Register Start Offset		Data Number of Registers		Error Check Field	(CRC-16)
		High	Low	High	Low		
01	03	00	78	00	06	45	D1

### 5.2.2 Read Holding Register Response

The addressed slave responds with its address and function code, followed by the information field. The information field contains 1 byte describing the quantity of data bytes to be returned. The contents of each register requested (DATA) is two bytes, the first byte includes the high order bits and the second the low order bits.

**Example** – the response to the read holding register query shows the following:

- Alarm trip A1 – 150
- Alarm trip B1 – 50
- Alarm trip C1 – 100
- Alarm trip D1 – 400
- Alarm trip A2 – 0
- Alarm trip B2 – 0

Address	Function	Byte Count	Holding Register 121		Holding Register 122		Holding Register 123		Holding Register 124		Holding Register 125		Holding Register 126		Error Check Field (CRC-16)	
			High	Low	High	Low	High	Low	High	Low	High	Low	High	Low		
01	03	0C	00	96	00	32	00	64	00	90	00	00	00	00	D9	91

### 5.3 Force Single Coil – Function Code 05

#### 5.3.1 Force Single Coil Query

This message forces a single coil either ON or OFF. The data value 65,280 (FF00 HEX) sets the coil ON and the value zero turns it OFF. All other values are illegal and do not affect the coil.

**Note.** To write to a coil the coil offset address must be used, e.g. to write to coil 149, the coil address 148(94H) is transmitted.

The use of slave address zero (broadcast mode) forces all attached slaves to modify the desired coil.

**Example** – a force single coil request to switch ON coil address 149 (auto/manual state, channel 1) in slave 01 is shown below.

Address	Function	Coil Offset		Data Value High		Error Check Field (CRC-16)	
		High	Low	High	Low		
01	05	00	94	FF	00	CD	D6

#### 5.3.2 Force Single Coil Response

The response is confirmation of the query after the coil state has been altered.

**Example:**

Address	Function	Coil Offset		Data Value High		Error Check Field (CRC-16)	
		High	Low	High	Low		
01	05	00	94	FF	00	CD	D6

## 5.4 Preset Single Register – Function Code 06

### 5.4.1 Preset Single Register Query

The preset single register allows the user to modify the contents of a holding register.

**Note.** Function codes 5, 6 and 16 are the only messages that are recognized as valid for broadcast.

**Example** – a preset single register request to write the value 500 to holding register address 121 (alarm trip A1) in slave 01 is shown below.

**Note.** To write to a register, the register's offset address must be used, e.g. to write to register 121, the offset address 120(78H) is transmitted.

Address	Function	Register Offset		Data Value		Error Check Field (CRC-16)	
		High	Low	High	Low		
01	06	00	78	01	F4	09	C4

### 5.4.2 Preset Single Register Response

The normal response to a preset single register request is to retransmit the query message after the register has been altered.

**Example:**

Address	Function	Register Offset		Data Value		Error Check Field (CRC-16)	
		High	Low	High	Low		
01	06	00	78	01	F4	09	C4

## 5.5 Loopback Test – Function Code 08

### 5.5.1 Loopback Test Query

The purpose of the loopback test is to test the Modbus system, it does not affect the content of the controller. Variations in the response may indicate faults in the Modbus system. The information field contains 2 bytes for the designation of the diagnostic code followed by 2 bytes to designate the action to be taken.

**Example:**

Address	Function	Data Diagnostic Code		Data*	Data*	Error Check Field (CRC-16)	
		High	Low				
01	08	00	00	A5	37	DA	8D

\*These are considered to be the information fields for diagnostic mode.

### 5.5.2 Loopback Test Response

The response always echoes the query, only diagnostic code 0 (bytes 3 and 4) can be used.

**Example:**

Address	Function	Data Diagnostic Code		Data*	Data*	Error Check Field (CRC-16)	
		High	Low				
01	08	00	00	A5	37	DA	8D

\*These are considered to be the information fields for diagnostic mode.

## 5.6 Write Multiple Registers – Function Code 16

### 5.6.1 Write Multiple Registers Query

Holding registers existing within the controller can have their contents changed by this message (a maximum of 8 registers). When used with slave address zero (broadcast mode) all slave controllers load the selected registers with the contents specified.

**Example** – a write multiple register request to write the value 10 to the register address 121 and the value 100 to the register address 122 in slave 01 is shown below.

Address	Function	Register Start Offset		Number of Registers		Byte Count	Holding Register 121		Holding Register 122		Error Check Field (CRC-16)	
		High	Low				High	Low	High	Low		
01	10	00	78	00	02	04	00	0A	00	64	D4	C4

### 5.6.2 Write Multiple Registers Response

The response confirms slave identification, function code, starting register address and quantity only.

**Example:**

Address	Function	Register Start Offset		Number of Registers			Error Check Field (CRC-16)	
		High	Low					
01	10	00	78	00	02	00	10	90

## 6 Exception Responses

The exception response codes sent by the slave are shown in Table 6.1. When a slave detects one of these errors, it sends a response message to the master consisting of slave address, function code, error code and error check fields.

Exception Response Code	Exception Response Name	Exception Response Definition
01	Illegal Function	The message function received is not an allowable action for the C1300.
02	Illegal Data Address	The address reference in the data field is not an allowable address for the C1300.
03	Illegal Data Value	The value referenced in the data field is not allowable in the addressed slave location.
07	Negative Acknowledgment	The function just requested cannot be performed.
08	Memory Parity Error	Parity check indicates an error in one or more of the characters received.

Table 6.1 Exception Response Codes

### 6.1 Examples

A read register request to read holding register address 251 of slave 01 (undefined address for slave, beyond address limit) is shown below.

Slave Address	Function	Register Start Offset		Number of Registers		Error Check Field (CRC-16)	
		High	Low	High	Low		
01	03	00	FA	00	06	E5	F9

The response returns exception response code 02, 'Illegal Data Address'. To indicate that the response is a notification of an error, the most significant bit of the function code is set to 1.

Slave Address	Function	Exception Code	Error Check Field (CRC-16)	
01	83	02	C0	F1

## 7 Modbus Registers

### 7.1 Coils

Coil Number	Read/Write	Description	Response/Entry
<b>Input Failure States</b>			
011	R	Main Input	0 = Active 1 = Failed
012	R	Module 2	
013	R	Module 3	
014	R	Module 4	
015	R	Module 5	
<b>A to D Converter Failure States</b>			
021	R	Main Converter	0 = Active 1 = Failed
022	R	Module 2	
023	R	Module 3	
024	R	Module 4	
025	R	Module 5	
<b>Alarm Status</b>			
031	R	Alarm A Channel 1	0 = Inactive 1 = Active
032	R	Alarm B Channel 1	
033	R	Alarm C Channel 1	
034	R	Alarm D Channel 1	
035	R	Alarm A Channel 2	
036	R	Alarm B Channel 2	
037	R	Alarm C Channel 2	
038	R	Alarm D Channel 2	
039	R	Alarm A Channel 3	
040	R	Alarm B Channel 3	
041	R	Alarm C Channel 3	
042	R	Alarm D Channel 3	
043	R	Alarm A Channel 4	
044	R	Alarm B Channel 4	
045	R	Alarm C Channel 4	
046	R	Alarm D Channel 4	
<b>Digital Input States</b>			
051	R	Main Module Digital Input 1	0 = Inactive 1 = Active
052	R	Main Module Digital Input 2	
061	R	Module 2 Digital Input 1	
062	R	Module 2 Digital Input 2	
071	R	Module 3 Digital Input 1	
072	R	Module 3 Digital Input 2	
081	R	Module 4 Digital Input 1	
082	R	Module 4 Digital Input 2	
083	R	Module 4 Digital Input 3	
084	R	Module 4 Digital Input 4	
085	R	Module 4 Digital Input 5	
086	R	Module 4 Digital Input 6	
087	R	Module 4 Digital Input 7	
088	R	Module 4 Digital Input 8	
091	R	Module 5 Digital Input 1	
092	R	Module 5 Digital Input 2	
093	R	Module 5 Digital Input 3	
094	R	Module 5 Digital Input 4	
095	R	Module 5 Digital Input 5	
096	R	Module 5 Digital Input 6	
097	R	Module 5 Digital Input 7	
098	R	Module 5 Digital Input 8	

Table 7.1 Coils



Coil Number	Read/Write	Description	Response/Entry
<b>Logic Equation Results</b>			
121	R	Logic Equation 1	0 = Inactive 1 = Active
122	R	Logic Equation 2	
123	R	Logic Equation 3	
124	R	Logic Equation 4	
125	R	Logic Equation 5	
126	R	Logic Equation 6	
127	R	Logic Equation 7	
128	R	Logic Equation 8	
<b>Real Time States</b>			
131	R	Channel 1	0 = Inactive 1 = Active
132	R	Channel 2	

Table 7.1 Coils (Continued)

## 7.2 Holding Registers

Register Number	Read/Write	Description	Response/Entry
011	R	<b>Analog Input 1</b> High Word	Engineering Units Range -99999 to +99999
012	R	Low Word	
		<b>Analog Input 2</b>	
013	R	High Word	
014	R	Low Word	
		<b>Analog Input 3</b>	
015	R	High Word	
016	R	Low Word	
		<b>Analog Input 4</b>	
017	R	High Word	
018	R	Low Word	
		<b>Analog Input 5</b>	
019	R	High Word	
020	R	Low Word	
		<b>Analog Input 6</b>	
021	R	High Word	
022	R	Low Word	
		<b>Math Result 1</b>	
023	R	High Word	
024	R	Low Word	
		<b>Math Result 2</b>	
025	R	High Word	
026	R	Low Word	
		<b>Math Result 3</b>	
027	R	High Word	
028	R	Low Word	
		<b>Math Result 4</b>	
029	R	High Word	
030	R	Low Word	
		<b>Engineering Ranges Decimal Point Position</b>	
041	R	Input 1	
042	R	Input 2	
043	R	Input 3	
044	R	Input 4	
045	R	Input 5	
046	R	Input 6	
047	R	Math Block 1	
048	R	Math Block 2	
049	R	Math Block 3	
050	R	Math Block 4	

Table 7.2 Holding Registers

### 7.3 Alarm Settings

Register Number	Read/Write	Description	Response/Entry
<b>Alarm Settings</b>			
121	R/W	Alarm A Trip Value Channel 1 (High)	
122	R/W	Alarm A Trip Value Channel 1 (Low)	
123	R/W	Alarm B Trip Value Channel 1 (High)	
124	R/W	Alarm B Trip Value Channel 1 (Low)	
125	R/W	Alarm C Trip Value Channel 1 (High)	
126	R/W	Alarm C Trip Value Channel 1 (Low)	
127	R/W	Alarm D Trip Value Channel 1 (High)	
128	R/W	Alarm D Trip Value Channel 1 (Low)	
129	R/W	Alarm A Trip Value Channel 2 (High)	
130	R/W	Alarm A Trip Value Channel 2 (Low)	
131	R/W	Alarm B Trip Value Channel 2 (High)	
132	R/W	Alarm B Trip Value Channel 2 (Low)	
133	R/W	Alarm C Trip Value Channel 2 (High)	
134	R/W	Alarm C Trip Value Channel 2 (Low)	
135	R/W	Alarm D Trip Value Channel 2 (High)	
136	R/W	Alarm D Trip Value Channel 2 (Low)	
137	R/W	Alarm A Trip Value Channel 3 (High)	
138	R/W	Alarm A Trip Value Channel 3 (Low)	
139	R/W	Alarm B Trip Value Channel 3 (High)	
140	R/W	Alarm B Trip Value Channel 3 (Low)	
141	R/W	Alarm C Trip Value Channel 3 (High)	
142	R/W	Alarm C Trip Value Channel 3 (Low)	
143	R/W	Alarm D Trip Value Channel 3 (High)	
144	R/W	Alarm D Trip Value Channel 3 (Low)	
145	R/W	Alarm A Trip Value Channel 4 (High)	
146	R/W	Alarm A Trip Value Channel 4 (Low)	
147	R/W	Alarm B Trip Value Channel 4 (High)	
148	R/W	Alarm B Trip Value Channel 4 (Low)	
149	R/W	Alarm C Trip Value Channel 4 (High)	
150	R/W	Alarm C Trip Value Channel 4 (Low)	
151	R/W	Alarm D Trip Value Channel 4 (High)	
152	R/W	Alarm D Trip Value Channel 4 (Low)	
			-99999 to +99999 for High/Low Process Alarms 5 to 5000 (0.5 to 500.0%) for Fast/Slow Rate Alarms
161	R	Alarm A Type Channel 1	
162	R	Alarm B Type Channel 1	
163	R	Alarm C Type Channel 1	
164	R	Alarm D Type Channel 1	
165	R	Alarm A Type Channel 2	
166	R	Alarm B Type Channel 2	
167	R	Alarm C Type Channel 2	
168	R	Alarm D Type Channel 2	
169	R	Alarm A Type Channel 3	
170	R	Alarm B Type Channel 3	
171	R	Alarm C Type Channel 3	
172	R	Alarm D Type Channel 3	
173	R	Alarm A Type Channel 4	
174	R	Alarm B Type Channel 4	
175	R	Alarm C Type Channel 4	
176	R	Alarm D Type Channel 4	
			0 = Alarm Off 1 = High Process 2 = Low Process 3 = Fast Rate 4 = Slow Rate

Table 7.3 Alarm Settings

#### 7.4 Chart Settings

Register Number	Read/Write	Description	Response/Entry
181 182	R/W R	<b>Chart Settings</b> Chart Rotation Time Pen Lift Status	1 to 167 Hrs, 168 = 7 Days to 193 = 32 Days 0 = Pen down, 1 = Pen up

Table 7.4 Chart Settings

### 7.5 Totalizer Settings

Register Number	Read/Write	Description	Response/Entry
191 192 193 194 195 196 197 198	R R R R R R R R	<b>Predetermined Value Channel 1*</b> High Word Low Word <b>Preset Value Channel 1*</b> High Word Low Word <b>Front-panel Totalizer Value Ch. 1*</b> High Word Low Word <b>Secure Totalizer Value Ch. 1*</b> High Word Low Word	The Limit for High Word:Low Word linked together is 0 to 99,999,999
201 202 203 204 205 206 207 208	R R R R R R R R	<b>Predetermined Value Ch. 2*</b> High Word Low Word <b>Preset Value Channel 2*</b> High Word Low Word <b>Front-panel Totalizer Value Ch. 2*</b> High Word Low Word <b>Secure Totalizer Value Ch. 2*</b> High Word Low Word	The Limit for High Word:Low Word linked together is 0 to 99,999,999
211 212 213 214 215 216 217 218	R R R R R R R R	<b>Predetermined Value Channel 3*</b> High Word Low Word <b>Preset Value Channel 3*</b> High Word Low Word <b>Front-panel Totalizer Value Ch. 3*</b> High Word Low Word <b>Secure Totalizer Value Channel 3*</b> High Word Low Word	The Limit for High Word:Low Word linked together is 0 to 99,999,999
221 222 223 224 225 226 227 228	R R R R R R R R	<b>Predetermined Value Channel 4*</b> High Word Low Word <b>Preset Value Channel 4*</b> High Word Low Word <b>Front-panel Totalizer Value Ch. 4*</b> High Word Low Word <b>Secure Totalizer Value Channel 4*</b> High Word Low Word	The Limit for High Word:Low Word linked together is 0 to 99,999,999

\*These values are a combination of the High Word and Low Word.

Table 7.5 Totalizer Settings

## Notes

# PRODUCTS & CUSTOMER SUPPORT

## Products

### Automation Systems

- for the following industries:
  - Chemical & Pharmaceutical
  - Food & Beverage
  - Manufacturing
  - Metals and Minerals
  - Oil, Gas & Petrochemical
  - Pulp and Paper

### Drives and Motors

- AC and DC Drives, AC and DC Machines, AC Motors to 1kV
- Drive Systems
- Force Measurement
- Servo Drives

### Controllers & Recorders

- Single and Multi-loop Controllers
- Circular Chart and Strip Chart Recorders
- Paperless Recorders
- Process Indicators

### Flexible Automation

- Industrial Robots and Robot Systems

### Flow Measurement

- Electromagnetic Flowmeters
- Mass Flowmeters
- Turbine Flowmeters
- Wedge Flow Elements

### Marine Systems & Turbochargers

- Electrical Systems
- Marine Equipment
- Offshore Retrofit and Refurbishment

### Process Analytics

- Process Gas Analysis
- Systems Integration

### Transmitters

- Pressure
- Temperature
- Level
- Interface Modules

### Valves, Actuators and Positioners

- Control Valves
- Actuators
- Positioners

### Water, Gas & Industrial Analytics Instrumentation

- pH, Conductivity and Dissolved Oxygen Transmitters and Sensors
- Ammonia, Nitrate, Phosphate, Silica, Sodium, Chloride, Fluoride, Dissolved Oxygen and Hydrazine Analyzers
- Zirconia Oxygen Analyzers, Katharometers, Hydrogen Purity and Purge-gas Monitors, Thermal Conductivity

## Customer Support

We provide a comprehensive after sales service via a Worldwide Service Organization. Contact one of the following offices for details on your nearest Service and Repair Centre.

### United Kingdom

ABB Limited  
Tel: +44 (0)1480 475321  
Fax: +44 (0)1480 217948

### United States of America

ABB Inc.  
Tel: +1 215 674 6000  
Fax: +1 215 674 7183

### Client Warranty

Prior to installation, the equipment referred to in this manual must be stored in a clean, dry environment, in accordance with the Company's published specification.

Periodic checks must be made on the equipment's condition. In the event of a failure under warranty, the following documentation must be provided as substantiation:

1. A listing evidencing process operation and alarm logs at time of failure.
2. Copies of all storage, installation, operating and maintenance records relating to the alleged faulty unit.

Modbus is a registered trademark of the Modbus-IDA organization  
IBM is a registered trademark of International Business Machines Corporation

**ABB** has Sales & Customer Support expertise  
in over 100 countries worldwide

[www.abb.com](http://www.abb.com)

The Company's policy is one of continuous product  
improvement and the right is reserved to modify the  
information contained herein without notice.

Printed in UK (11.06)

© ABB 2006



**ABB Limited**  
Howard Road, St. Neots  
Cambridgeshire  
PE19 8EU  
UK  
Tel: +44 (0)1480 475321  
Fax: +44 (0)1480 217948

**ABB Inc.**  
125 E. County Line Road  
Warminster  
PA 18974  
USA  
Tel:+1 215 674 6000  
Fax:+1 215 674 7183