

**FULSCOPE® ER/C
MICROPROCESSOR-BASED RECORDING CONTROLLER
with Automatic Tuning**

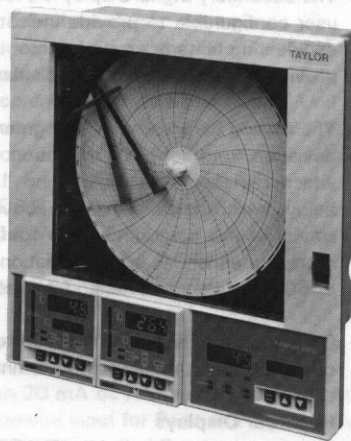

- Isolated Process Inputs
- ± 0.1% Accuracy
- Control up to 2 Variables
- Automatic Tuning
- NEMA 3 Enclosure
- Integration and Totalization
- Ramp/Soak Profile

PRODUCT DESCRIPTION

GENERAL

The FULSCOPE® ER/C Recording Controller is a microprocessor-based instrument that can be used to record and control up to two measured process variables, and record a third. Process input capability for each pen is user selectable for direct connection of thermocouple, RTD, mV dc, V dc, or mA dc input. Ranging is automatic. All process inputs are galvanically isolated from the rest of the instrument. All thermocouple and RTD linearization is automatically performed. Square-law linearization is user configurable. A 24V dc, nonisolated, transmitter power supply is provided on each pen for use with two-wire mA dc inputs.

Open Input Detection is provided for each pen (all input types). Upon detection of an open input, indication of this fault condition is displayed: the respective pen moves to the 0% position; and the controller output, if a controlled pen, moves to a user preset value.

Record functions, control functions, alarm settings, and other parameters are easily configured via front face mounted keys and easily understood display prompts. All configuration is protected via the instrument's security access system and is contained within nonvolatile memory.

CONTROL CAPABILITY

Each control unit specified on the FULSCOPE ER/C is user configurable to provide either on/off, P, PI, PD, or full PID control response with **automatic tuning** of all PID parameters. The instrument's control output is selectable as either SPDT relay or 4 to 20 mA dc. The SPDT relay provided with each control unit can be used as either a control output or as a single-alarm output.

User-selectable control implementations for the FULSCOPE ER/C include:

- **On/Off** (SPDT relay) cycles the relay on and off. This control implementation is provided with a user-configurable, differential gap setting. It is user selectable on each control unit specified. The 4 to 20 mA dc output is inactive in this control implementation.
- **Time Proportioning** (SPDT relay) cycles the relay on and off in proportion to the PID algorithm. It is user selectable on each control unit specified. The 4 to 20 mA dc output is inactive in this control implementation.
- **Current Proportioning** (4 to 20 mA dc) supplies a variable current output in proportion to the PID algorithm. It is user selectable on

each control unit specified. The SPDT relay is active as a single-alarm output in this control implementation.

- **Dual Output (Heat/Cool)** with one Current Proportioning output (heat) and one Time Proportioning output (cool). It is user selectable on each control unit specified. This control implementation uses both the 4 to 20 mA dc and SPDT relay outputs provided with each controlled pen specified.
- **Dual Output (Heat/Cool)** with two Time Proportioning outputs (SPDT relays). It is user selectable on each control unit when the controlled pen is specified with its respective Digital Option Module. This control implementation uses the two SPDT relays provided with the Digital Option Module for control. The standard SPDT relay is used as a single-alarm output and the 4 to 20 mA dc output is inactive in this control implementation.
- **Position Proportioning** (SPDT relays) positions an electric valve motor in proportion to the PID algorithm. It is user selectable on the red pen only and requires the optional valve position slidewire feedback input provided on the Analog Option Module, and the pen's respective Digital Option Module. This implementation uses the two SPDT relays provided with the Digital Option Module for control. The standard SPDT relay is used as a single-alarm output and the 4 to 20 mA dc output is inactive in this control implementation.
- **Ramp/Soak Profile** option complements any type of control implementation and adds a ramp/soak profile with up to 10 segments of set-point ramp (up or down) or soak. The profile is run in either hours or minutes and each segment can be up to 999.9 units of time. Ramp/Soak features include: repeating profile, resetting profile, skipping segments, guaranteed ramps and soaks, and segment event state (requires digital option module). Up to three profiles can be linked to form one profile 30 segments long.

Control features, for each control unit, include automatic tuning of all PID parameters, bumpless auto/manual transfer, output limiting, set-point limiting, set-point tracking, anti-reset windup control, and a configurable cold-start value. The automatic tuning feature is an on-demand, user-activated feature that eliminates time-consuming manual tuning routines. Once tuning parameters are automatically set, they can be easily and quickly changed manually. If manual tuning is required, automatic tuning need not be used. Anti-reset windup control and the configurable cold-start value are included to eliminate overshoot that commonly occurs during and after process startup.

File 11-8

In addition to the standard features mentioned above, the FULSCOPE ER/C is also available with an **Analog Option Module that provides all of the following control features for the red pen:**

- **Remote Set-Point Input** – This input accepts a 4 to 20 mA dc remote signal which can be taken directly as the control set-point or conditioned with both a Ratio and Bias adjustment before being used as a control set-point. In this configuration, the instrument can be used in Cascade, Ratio, and Biasing applications.
- **Slidewire Feedback Input** – This input is a resistance input of 2,000 ohms maximum. It is required for the Position Proportioning control implementation and allows the instrument to accept a valve position feedback.
- **Retransmission Output** – The instrument's Analog Option Module (any one pen) is also provided with a linear and scaled 4 to 20 mA dc retransmission of the measured process variable. In addition, if red or green pens are installed, but used to record only, their outputs can be used as retransmission and assigned to any installed pen. This process variable output provides additional load capability for transmitting the measured variable to a remote location.

Each controlled pen is available with a **Digital Option Module that provides the following control features:**

- **Digital Input** – This input accepts a remote signal that will change auto/manual status on the red and green pens.
- **(2) SPDT Relays** – These relays are used to perform either Heat/Cool control with two Time Proportioning outputs or Position Proportioning control (red pen only). If not being used for control, these relays are used for independent HI and LO alarm outputs.

Also, when the FULSCOPE ER/C is specified with two Pens (red and green) controlled, a Cascade control implementation is user configurable. This implementation uses the red pen as the Master control unit and the green pen as the Slave control unit.

RECORDER CAPABILITY

The instrument incorporates a 10-in. circular chart for use with up to three pens: red, green, and blue.

Each pen is also user selectable as an event marker if not selected as control pen. The event pen(s) will record on the outside edge of the chart. Upon an event occurrence, the pen will drive inward to a preset position and record at that point for the duration of the event, and the alarm relay will change state.

A convenient Pen Change/Chart Change switch provides quick and unobstructed access to the instrument chart or pens for easy replacements. A snapdown chart hub allows for convenient chart changes.

Totalization with user configurable 7 digit counter and provisions for: Displayed Negative Sign, Reset Function, Predetermining Counter, Count Direction and Preset Values.

DISPLAYS**Control Unit Displays**

Each pen that is specified as controlled is provided with an operator interface that includes two digital displays, one analog bargraph, and a variety of status and alarm indications.

The Main Digital Display is a four-digit red LED display used solely to indicate the measured process variable. This display is in linear engineering units. Display resolution for thermocouple and RTD inputs is user configurable to either 0.1 or 1 degree. For mV dc, V dc, and mA dc inputs, the decimal point is user configurable for

fixing resolution at either 0001., 000.1, 00.01, or 0.001 engineering units. Configuration of the decimal point position sets the display's minimum and maximum engineering unit limits. Engineering unit identification is user selectable using labels provided with each instrument.

The Secondary Digital Display is a four-digit red LED display that is user configurable to provide indication of controller set-point in engineering units or control output in %. A LED status indication provides identification of this display.

The Analog Bargraph is a 21-segment LED bargraph that provides deviation from set-point indication. There is a green center bar, which represents set-point, and 10 red segments above and below, which indicate deviation above or below set-point. The sensitivity of this bargraph is user configurable for each segment to represent either 1% or 5% deviation. This provides either $\pm 10\%$ or 50% maximum deviation from set-point indication.

Other status LEDs provide indication of auto tuning, manual mode of operation, remote analog input, communications status, and alarms.

Recorder Displays

The recorder functions of the FULSCOPE ER/C Recording Controller, in addition to the charting functions previously discussed, are provided with a unique set of LED displays. This includes two digital displays and alarm status indications.

The Main Digital Display is a four-digit red LED display used to indicate the measured process variable of either of the pens specified as well as display prompts during instrument configuration. Status LEDs are provided to indicate which pen is being displayed.

The Secondary Digital Display is a four-digit red LED display used for display prompts during instrument configuration.

ALARMS

The FULSCOPE ER/C is provided with HI and LO red alarm LED indication on the front of the instrument for each pen. Alarm settings include both Process and Deviation (controlled pens only) types. The standard SPDT relay is user selectable as a single-alarm output. All alarm settings will activate this output. For the red and green pens, the respective Digital Option Module can be added for independent HI and LO alarm outputs (two SPDT relays). If the Digital Option Module is being used for control purposes (Heat/Cool Time Proportioning or Position Proportioning), then the respective pen will not be available with independent HI and LO alarm outputs. In this case, the standard SPDT relay will be used as a single alarm output.

Alarm acknowledgement is user configurable. Alarm relays are also user configurable as either on/off or latching action. Relays are provided as "fail safe" (instrument power loss results in relay alarm condition).

HOUSING

The instrument housing is a molded, glass fiber filled reinforced polyester that provides excellent corrosion resistance. The instrument meets NEMA 3 requirements.

Instrument installation is quickly and easily accomplished via use of either the standard panel and surface mounting configurations, or the optional mounting kits specified in Specification Sheet File 16-24 for panel, surface, pipe, and existing installations.

COMMUNICATIONS

An optional RS-422 serial communications port provides bidirectional communication with read/write capability. This communications port can be quickly and easily added to any FULSCOPE ER/C recording controller at any time.

FEATURES

- Microprocessor control of linearization, ranging, control functions, alarms, and other parameters
- Universal input capabilities include: thermocouples, RTDs, mV dc, V dc, and mA dc
- Galvanic isolation of process inputs
- Record and control up to two variables, and record a third
- Auto tuning of control parameters
- Full PID control in four forms. With single or dual control output.
- Anti-reset windup control
- Glass fiber filled reinforced polyester housing meets NEMA 3 requirements
- Two digital displays and one analog display for each control loop
- Tactile feedback keys and configuration prompts
- Nonvolatile memory and security access
- RS-422 communications port

BENEFITS

- Improved accuracy and ease of operation
- Standardization saves money
- Allows grounded inputs and reduces measurement errors
- Reduces plant process control costs
- Saves startup time and expense
- A universal controller — easily adapted to changing process requirements
- Minimizes overshoot for improved process control
- No need for special housing outside the control room — increases installation flexibility
- Presents all critical control parameters at a single glance, reducing operator interface time
- Simplifies and speeds configuration; reduces errors
- Ensures control integrity
- Communications capability for improved process quality via remote monitoring and control

SPECIFICATIONS

FUNCTIONAL CHARACTERISTICS

General

Power Supply 120/240V ac ± 10%, 50/60 Hz **Power Consumption** 40W

Inputs

Ranging of all inputs is automatic.

	Min.	Max.	Min. Span
Voltage			
mV dc	0	100	20
V dc	0	10	0.2

Thermocouples

Type	Measuring Range Limit
Type J	-328 to 2192 °F (-200 to 1200 °C)
Type K	-328 to 2498 °F (-200 to 1370 °C)
Type R	32 to 3002 °F (0 to 1650 °C)
Type S	32 to 3002 °F (0 to 1650 °C)
Type E	-328 to 1832 °F (-200 to 1000 °C)
Type T	-328 to 752 °F (-200 to 400 °C)

	Min.	Max.	Min. Span
Current			
mA dc	4	20	1

Input Impedance	10M ohms minimum
Millivolt	10M ohms minimum
Volt	100 ohms nominal
Current	

Linearization Automatic for thermocouple and RTD inputs. Configurable for square law. Per NBS125 and IEC584 standards Per IEC751 and DIN 43760 standards

Input Resolution 14 bit (1 part in 16,000).

Isolation Galvanic isolation; 10M ohms minimum on process inputs

RTD (Resistance Temperature Detector)

Type 3-wire platinum, 100-ohm
Measuring Range Limits -328 to 1562 °F (-200 to 850 °C)

Transmitter Power Supply Nonisolated 24V dc supply for 20-mA loop. Loop should not be externally grounded.

Control

Each control unit is provided with P, PI, PD, or full PID control responses with Auto Tuning and Anti-Reset Windup control. A second set of tuning constants is provided when Dual Output (Heat/Cool) control is selected.

Auto Tuning	On-demand automatically determines appropriate PID values for optimum process control on primary output.	Differential Gap (On-Off Control)	0 to 100% in 0.1% steps
Proportional Band	0.1 to 999.9% in 0.1% steps	Position Feedback Slidewire	130 ohms minimum; 2,000 ohms maximum
Integral (Reset)	0.9 to 999.9 seconds in steps of 0.1 Sec	Anti-Reset Windup	Minimizes overshoot by inhibiting integral action. Standard on all control forms except On/Off.
Derivative (Rate)	0 to 999.9 seconds in steps of 0.1 Sec 0.0 = OFF	Auto/Manual	Procedureless, bumpless transfer
Cycle Time	1.0 to 300 seconds in steps of 0.1 Sec	Manual Output	0 to 100% in 0.1% steps
Cold Start Value	0 to 100% in steps of 0.1%	Set-Point Limiting	Minimum and maximum limits can be set
Bias (Remote Set-Point)	-999 to 9999 (Engineering Units)	Remote Set-Point Input	4 to 20 mA dc; 250-ohms input impedance. Scaleable in engineering units.
Ratio (Remote Set-Point)	0.01 to 99.99 in 0.01 steps	Digital Input	TTL compatible; optically isolated 0V dc = OFF 5-24V dc = ON
Dead Band (Valve Control)	0.2 to 10% in 0.1% steps	Control Action	Direct or reverse
Output Limiting			
High Limit	Low limit to 100% in 0.1% steps		
Low Limit	0 to high limit in 0.1% steps		

Control Display

Up to two Control Units may be present. Each Control Unit is provided with the following displays.

Main Digital Display		Status Display	Yellow LEDs for status indication
Type	4-digit, 0.56-in. high red LEDs	Secondary Display	OUT – Output being displayed
Digits	7-segment: -999 to 9999, automatic positioning of (-)	Other	REM – Remote Analog Input or Ramp/Soak active when flashing MAN – Manual mode of operation COM – RS-422 Communications AUTO – Automatic Tuning; flashes TUNE when auto tuning is in progress
Secondary Digital Display		Alarm Display	Red LEDs for HI and LO alarm indication
Type	4-digit, 0.3-in. high red LEDs		
Digits	7-segment: -999 to 9999, automatic positioning of (-) and decimal		
Deviation Bargraph Display	21-segment LEDs configurable to either 1% or 5% deviation per segment. Red indicators with green center bar.		

Record Display

Chart	10 in. circular chart; 100 charts furnished with each instrument if standard range; 4 1/4 in. record length	Status Display	3 LEDs provide identification of main digital display indication for pen 1, 2, or 3; pen numbers and colors are cross-referenced
Chart Drive	DC stepper motor	Alarm Display	Red LEDs for HI and LO alarm indication
Chart Rotation	Configurable from 1 revolution per hour to 1 revolution per 168 hours (7 days) in increments of 1 hour	Pens	
		Type	Disposable, fiber-tipped
		Color	
		Pen 1	Red
		Pen 2	Green
		Pen 3	Blue
Digital Displays		Pen Resolution	0.1% of full scale
Main Digital Display		Event Marker	Each pen is user selectable as an event marker if not used for control
Type	4-digit, 0.56-in. high red LEDs		
Digits	7-segment: -999 to 9999, automatic positioning of (-)		
Secondary Digital Display			
Type	4-digit, 0.3-in. high red LEDs		
Digits	7-segment: -999 to 9999, automatic positioning of (-)		

Outputs

Current (red and green pens)	4 to 20 mA dc into 750 ohms maximum load	Optional (Cont'd) Retransmission	4 to 20 mA dc into 750 ohms maximum load applies to analog board, I/O board 1, and I/O board 2 RS-422 serial communications port providing bidirectional communication.
Relay Type	SPDT	Communications Link	
Contact Rating	5A at 120/240V ac		
Optional (red and green pens)			
Relay Type	2 SPDT, available for use as either heat/cool dual output time proportioning control, position proportioning open/close output or as dual alarm outputs		
Contact Rating	5A at 120/240V ac		

PERFORMANCE CHARACTERISTICS

Maximum Error Limits Voltage (V dc)	± 0.1% of actual input value or 20 mV, whichever is greater, for zero based input spans from 1.0 to 10V dc	Supply Voltage Influence	± 0.1% for ± 15% variations typical								
Millivolts	± 0.2% of actual input value or 20 µV, whichever is greater, for zero based spans, including volt inputs less than 1.0V dc	Sample Time	866 ms.								
Current	± 0.2% of actual input value or 20 µA, whichever is greater, for zero based spans	Linearizer Accuracy	± 0.1 °C (0.2 °F) typical								
RTD	± 0.2% of actual temperature input or 1.0 °C (1.8 °F), whichever is greater over the range of 0 to 600 °C (32 to 1112 °F)	Set-Point Resolution	<table border="1"> <thead> <tr> <th>Set-Point Type</th> <th>Resolution</th> </tr> </thead> <tbody> <tr> <td>Local</td> <td>± 1 digit</td> </tr> <tr> <td>Com Link</td> <td>± 1 digit</td> </tr> <tr> <td>Remote</td> <td>± 0.1%</td> </tr> </tbody> </table>	Set-Point Type	Resolution	Local	± 1 digit	Com Link	± 1 digit	Remote	± 0.1%
Set-Point Type	Resolution										
Local	± 1 digit										
Com Link	± 1 digit										
Remote	± 0.1%										
Thermocouple Type J, K, E, T	For ranges which are zero based or elevated above zero (°F, or, °C): ± 0.2% of actual temperature input or 1.0 °C (1.8 °F), whichever is greater	Data Retention	Typically 10 years with instrument unpowered. Data stored in nonvolatile memory. Approximately 10,000 cycles permitted.								
Type R, S	± 0.3% of span	Electrical Codes	General Purpose, Taylor Standard General Purpose, CSA certified								
Temperature Calibration	A user-configurable, single-point calibration facility is provided to reduce RTD and Thermocouple measurement error to 0.0° or any user-desired offset; Calibration adjustment is ± 15.0°.	Open Input Detection Description	Detection provided for thermocouple, RTD, mA, mV, and V dc inputs: Display indicates failure; pen goes to zero.								
Pen Response Time	9 seconds typically for full scale deflection	Output	0 to 100% in 1% steps								
Operating Conditions Temperature	32 to 131 °F (0 to 55 °C)	Common Mode Rejection	120 dB at 50/60 Hz								
Humidity	5 to 90% RH	Normal Mode Rejection	60 dB at 50/60 Hz								
Thermocouple Resistance	1,000 ohms maximum	Maximum Normal Mode Voltage	15V dc on thermocouple, mV, and volts								
RTD Resistance	10 ohms per lead (3-wire connection)	Line Interruption	No effect from ½ cycle dropout at nominal line voltage								
Temperature Stability	± 0.02% per °C typical	Line Interference	No effect from 500V for 125 µs								
		Security Access	User-configurable, 4-digit number; configurable read-only mode and hardware override; Switch on chart plate with hardware override								

PHYSICAL CHARACTERISTICS

Overall Size (approximate)		Housing Materials Door and Case	Glass fiber filled reinforced polyester molded for excellent corrosion resistance
Height	15.23 in. (387 mm)	Control Unit Face	
Width	15.04 in. (382 mm)		
Depth	5.57 in. (141 mm)		ABS plastic molded bezel with polycarbonate crystal overlay
Weight (approximate)	18 lb (8.2 kg)	Mounting	Panel or surface
Housing Protection	Meets NEMA 3 requirements		

DIMENSIONS

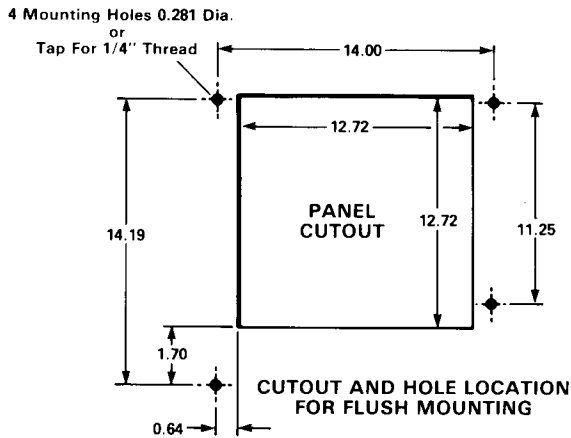
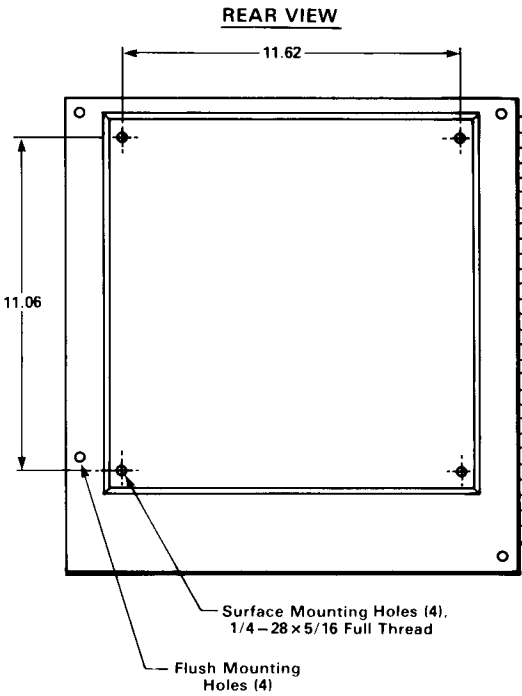
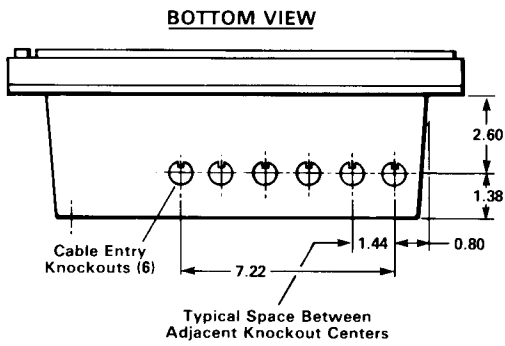
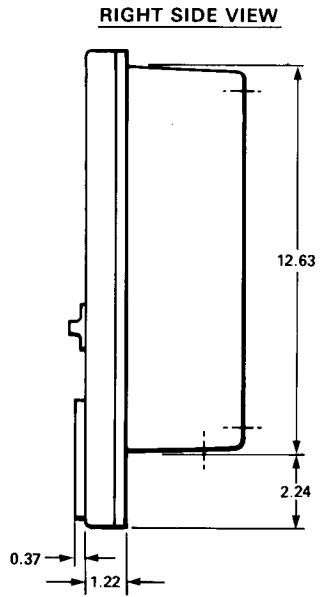
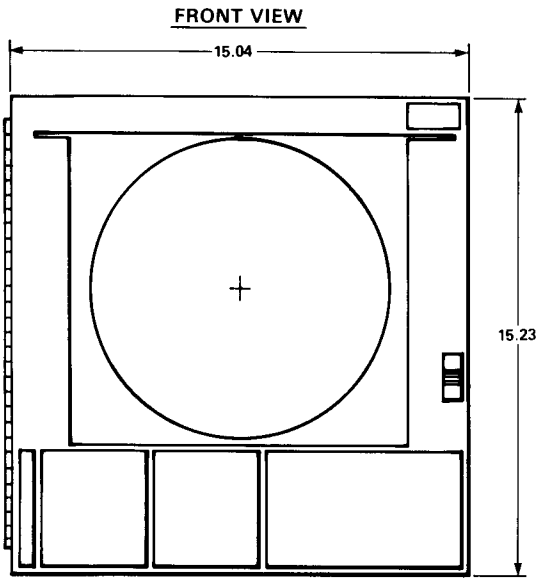

All dimensions in inches.
Not for construction purposes.

E-1107-839

ORDERING INFORMATION

1. Select one character or set of characters from each category and specify complete catalog number as per sample below.
2. Refer to File 16-24 for Accessories. Specify accessories as separate item(s) on order form.
3. Refer to File 9-13 for charts. Specify as separate item on order form. If not specified, 0 to 100 24-hr rotation charts will be provided.

BASE NUMBER – 1st thru 5th characters

- 1911R FULSCOPE® ER/C Recording Controller: One Control Unit (Red), One Pen (Red)
- 1912R FULSCOPE ER/C Recording Controller: One Control Unit (Red), Two Pens (Red, Green)
- 1913R FULSCOPE ER/C Recording Controller: One Control Unit (Red), Three Pens (Red, Green, Blue)
- 1922R FULSCOPE ER/C Recording Controller: Two Control Units (Red, Green), Two Pens (Red, Green)
- 1923R FULSCOPE ER/C Recording Controller: Two Control Units (Red, Green), Three Pens (Red, Green, Blue)

ELECTRICAL CODE – 6th character

- B General Purpose, CSA Certified No Extra

OPTION MODULE – 7th character

- 0 None No Extra
- 1 Analog Option Module on Red Pen
 - Includes: - Remote Analog input
 - 4 to 20 mA dc retransmission of measured variable
 - Slidewire input for Position Proportioning control
- 2 Digital Option Module on Red Pen
 - Includes: - Digital Input
 - Two Form C (SPDT) relays
 - Required for Heat/Cool dual relay output control, Position Proportioning control, or for use as dual alarm outputs
- 3 Analog and Digital Option Modules on Red Pen
 - Includes: - All capability as listed in 1 and 2 above
 - Required for Position Proportioning control
- 4 Digital Option Module on Green Pen
 - Includes: - All capability as listed in 2 above, except used for Green Pen
- 5 Combination of 1 and 4
- 6 Combination of 2 and 4
- 7 Combination of 3 and 4

OPTIONS – 8th character

- 0 None No Extra
- 1 RS-422 Serial Communications Port
- 3 Integrator/Totalizer
- 4 Combination of 1 and 3
- 5 Ramp/Soak Profile
- 6 Combination of 1 and 5
- 7 Combination of 3 and 5
- 8 Combination of 1, 3 and 5

DOOR – 9th character

- 1 Without Door Lock No Extra
- 2 With Door Lock

FIRMWARE VERSION – 10th and 11th characters

- 03 Version 3 No Extra

MODEL (Design Level) – 12th character

- A Model A

1911R B 1 0 1 03 A SAMPLE CATALOG NUMBER

RELATED INFORMATION

Instruction Book IB-11D101
 Quick Reference Guide 98354

Specifications subject to change without notice.