

INSTRUCTIONS

HI-FLOW™ VALVE WITH LIN-E-AIRE® ACTUATOR

2000V thru 2005V and 2010V thru 2015V Model A

with Actuator Termination No. 220, 221, 222, 223, 230, 231 or 233

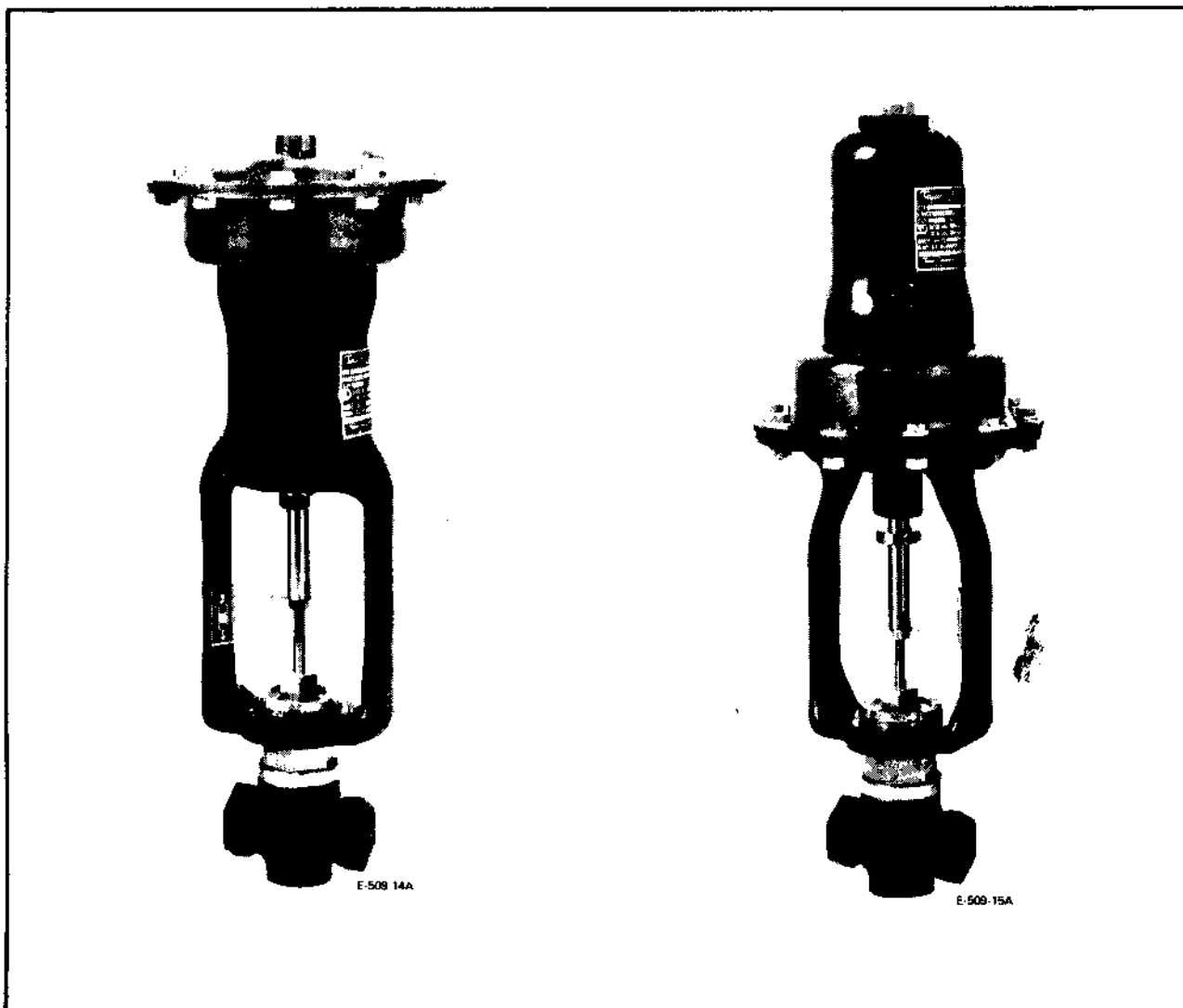

NOTICE

Information in this manual is intended only to assist our customers in the efficient operation of our equipment. Use of this manual for any other purpose is specifically prohibited and its contents are not to be reproduced in full or part without prior approval of Marketing Communications Department, Taylor Instrument Company, Division of Sybron Corporation.

Use of **DANGER, WARNING, CAUTION** and **NOTE**

This publication includes **DANGER, WARNING, CAUTION** and **NOTE** information where appropriate to point out safety related or other important information.

- DANGER** — Hazards which will result in severe personal injury or death.
- WARNING** — Hazards which could result in personal injury.
- CAUTION** — Hazards which could result in equipment or property damage.
- NOTE** — Alerts user to pertinent facts and conditions.

Although **DANGER** and **WARNING** hazards are related to personal injury, and **CAUTION** hazards are associated with equipment or property damage, it should be understood that operation of damaged equipment could, under certain operational conditions, result in degraded process system performance leading to personal injury or death. Therefore, comply fully with all **DANGER, WARNING** and **CAUTION** notices.

Prepared by:
MARKETING COMMUNICATIONS DEPARTMENT
TAYLOR INSTRUMENT COMPANY • DIVISION OF SYBRON CORPORATION
95 Ames Street, Rochester, New York 14601 U.S.A. 716-235-5000

TABLE OF CONTENTS

Para	Page	Para	Page
1 INTRODUCTION		4.4.1 Push-to-Close Valve with Air-to-Lower Actuator	27
1.1 Description	5	4.4.2 Push-to-Close Valve with Air-to-Raise Actuator or Push-to-Open with Air-to-Lower Actuator	28
1.1.1 General	5	4.5 Replacing Actuator Diaphragm	28
1.1.2 Hi-Flow Valve	5	4.5.1 Air-to-Lower Actuator	28
1.1.3 Lin-E-Aire Actuator	6	4.5.2 Air-to-Lower Actuator with Manual Operator	28
1.2 Serial and Catalog Numbers	8	4.5.3 Air-to-Raise Actuator	30
1.3 Technical Characteristics	9	4.6 Changing Actuator Range Spring	30
2 INSTALLATION		4.6.1 Air-to-Lower Actuator	30
2.1 Mounting	11	4.6.2 Air-to-Lower Actuator with Manual Operator	30
2.2 Pneumatic Connections	11	4.6.3 Air-to-Raise Actuator	32
3 OPERATION		4.7 Adjusting Actuator Range-Shop Procedure	33
3.1 Checking Valve Travel	18	4.7.1 Air-to-Lower Actuator with Push-to-Close Valve (ATC)	33
3.2 Adjusting Actuator Range	18	4.7.2 Air-to-Lower Actuator with Push-to-Open Valve (ATO)	33
3.2.1 Air-to-Lower Actuator	18	4.7.3 Air-to-Lower Actuator with Hand Wheel	34
3.2.2 Air-to-Lower Actuator with Manual Operator	19	4.7.4 Air-to-Raise Actuator with Push-to-Close Valve (ATO)	35
3.2.3 Air-to-Raise Actuator	20		
4 MAINTENANCE			
4.1 Test Equipment and Tools Required	21		
4.2 Disassembling Valve	21		
4.3 Assembling Valve	24		
4.4 Adjusting Valve Plug Travel	25		

ILLUSTRATIONS

Fig.	Page	Fig.	Page
1 Push-to-Close Valve	5	11 Travel Indicator Plate Showing Valve Plug Travel	18
2 Push-to-Open Valve	5	12 Adjusting Actuator Range	19
3 Air-to-Lower Actuator	6	13 Taylor Seat Ring Removal Tool, Part No. 153S22	22
4 Air-to-Raise Actuator	7	14 Exploded View of Control Valve	23
5 Removal Clearance Required	12	15 Taylor Valve Packing Tool, Part No. 153P9	25
6 Mounting Dimensions for Air-to-Lower Actuator	13	16 Standard Packing Spring Loaded TFE V-Ring	25
7 Mounting Dimensions for Air-to-Lower Actuator with Manual Operator (Accessory C)	14	17 Optional Packing Catalog No. Code J2 Spring Loaded Graphite	26
8 Mounting Dimensions for Air-to-Raise Actuator	15	18 Optional Packing Catalog No. Code J3 Lubricated Graphite with Lubricator	26
9 Mounting Dimensions for 2000V thru 2005V Hi-Flow Valves	16	19 Optional Packing Catalog No. Code J7 TFE V-Ring for Vacuum Service	26
10 Mounting Dimensions for 2010V thru 2015V Hi-Flow Valves	17		

TABLE OF CONTENTS

ILLUSTRATIONS (Cont'd)

Fig.	Page	Fig.	Page
20	Optional Packing Catalog No. Code J8 Double TFE V-Ring for Positive Pressure	28	Valve with Air-to-Lower Actuator Showing Air-to-Open (ATO) Action
	26		33
21	Optional Packing Catalog No. Code J9 Double TFE V-Ring for Negative Pressure	29a.	Actuator Input Pressure Versus Maxi- mum Differential Pressure for Termi- nation Nos. 220, 230 (20 Sq. In. Std)
	27		34
22	Optional Packing Catalog No. Code J10 Double TFE V-Ring for Alternate Positive and Negative Pressure	29b.	Actuator Input Pressure Versus Maxi- mum Differential Pressure for Termi- nation Nos. 221, 221C, 231 (45 Sq. In. Senior), 222, 222C (45 Sq. In. Std)
	27		35
23	Adjusting Valve Plug Travel	29c.	Actuator Input Pressure Versus Maxi- mum Differential Pressure for Termi- nation Nos. 223, 233C, 233 (80 Sq. In. Senior)
	27		36
24	Exploded View of Air-to-Lower Actuator	30	Valve with Air-to-Raise Actuator Showing Air-to-Open (ATO) Action
	29		36
25	Exploded View of Air-to-Raise Actuator		
	31		
26	Test Hookup		
	32		
27	Valve with Air-to-Lower Actuator Showing Air-to-Close (ATC) Action		
	33		

TABLES

Table	Page	Table	Page
1	Maximum Air Supply Pressure and Maximum Stroke	2	Tools Required
	10	3	Torque Values for Assembling Valve
			24

1

INTRODUCTION

1.1 DESCRIPTION

1.1.1 General

The primary function of Taylor 2-Way Hi-Flow valve is to accurately throttle fluid for process control purposes. The ability of the valve to shutoff tightly is a secondary function. The Hi-Flow valve with standard 316 stainless steel trim (seat ring, disc and stem assembly) has a leakage classification of ANSI Standard B16.104, Class IV.

The valve is available in a wide selection of constructions to meet process needs. Restricted trim allows for significant change in flow rates with only a trim change to the valve. No reduction in pipe size is necessary when using valves with restricted trim.

The Lin-E-Aire Valve Actuator is used for automatic operation of the Hi-Flow valve. The opening, closing or throttling of the valve plug in the valve body is accomplished by varying the air pressure to the diaphragm in the actuator.

The actuator spring and diaphragm are completely enclosed to protect them from dirt, dust or other foreign matter. Spring adjustments are made with a ball bearing spring adjustment sleeve. Diaphragm and spring assembly may easily be removed for replacement or substitution.

The construction and operating pressure range for the valve and actuator are listed on a data plate mounted on the actuator. Actuator size and spring are selected to meet the requirements of the application. In service the actuator should move the valve plug through its full travel when the pressure range stamped on the data plate is applied. This pressure range is generally 3 to 15 psi (20 to 100 kPa), but other ranges are available.

For precise control of valve plug position or where two valves are to be operated in sequence by one control device, a Taylor valve positioner, Catalog Number 100N, is recommended.

1.1.2 Hi-Flow Valve

There are two types of valves, Push-to-Close and Push-to-Open. Selection depends upon the valve action required in case of actuator air supply failure.

Push-to-Close type, Figure 1 — In this type of valve the valve stem moves downward, pushing the valve plug closer to its seat in the valve body. This movement decreases the flow through the valve.

Push-to-Open type, Figure 2 — In this type of valve the valve stem moves downward, pushing the valve plug away from its seat in the valve body. This movement increases the flow through the valve.

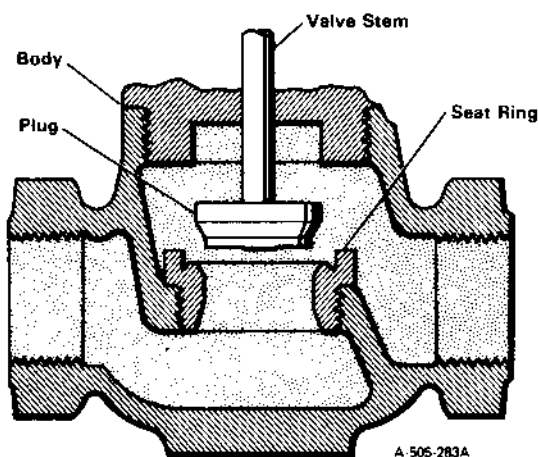

Figure 1. Push-to-Close Valve

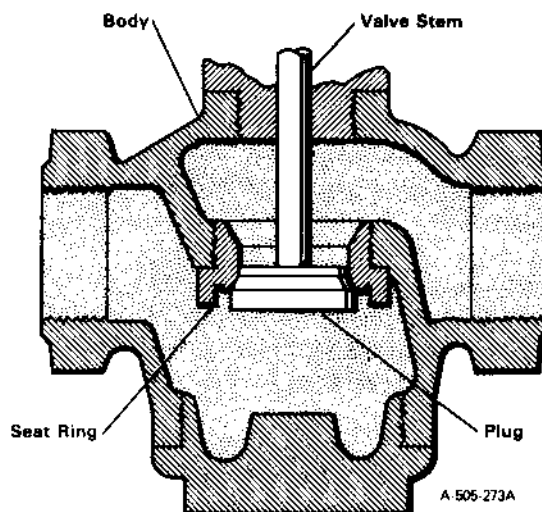

Figure 2. Push-to-Open Valve

INTRODUCTION

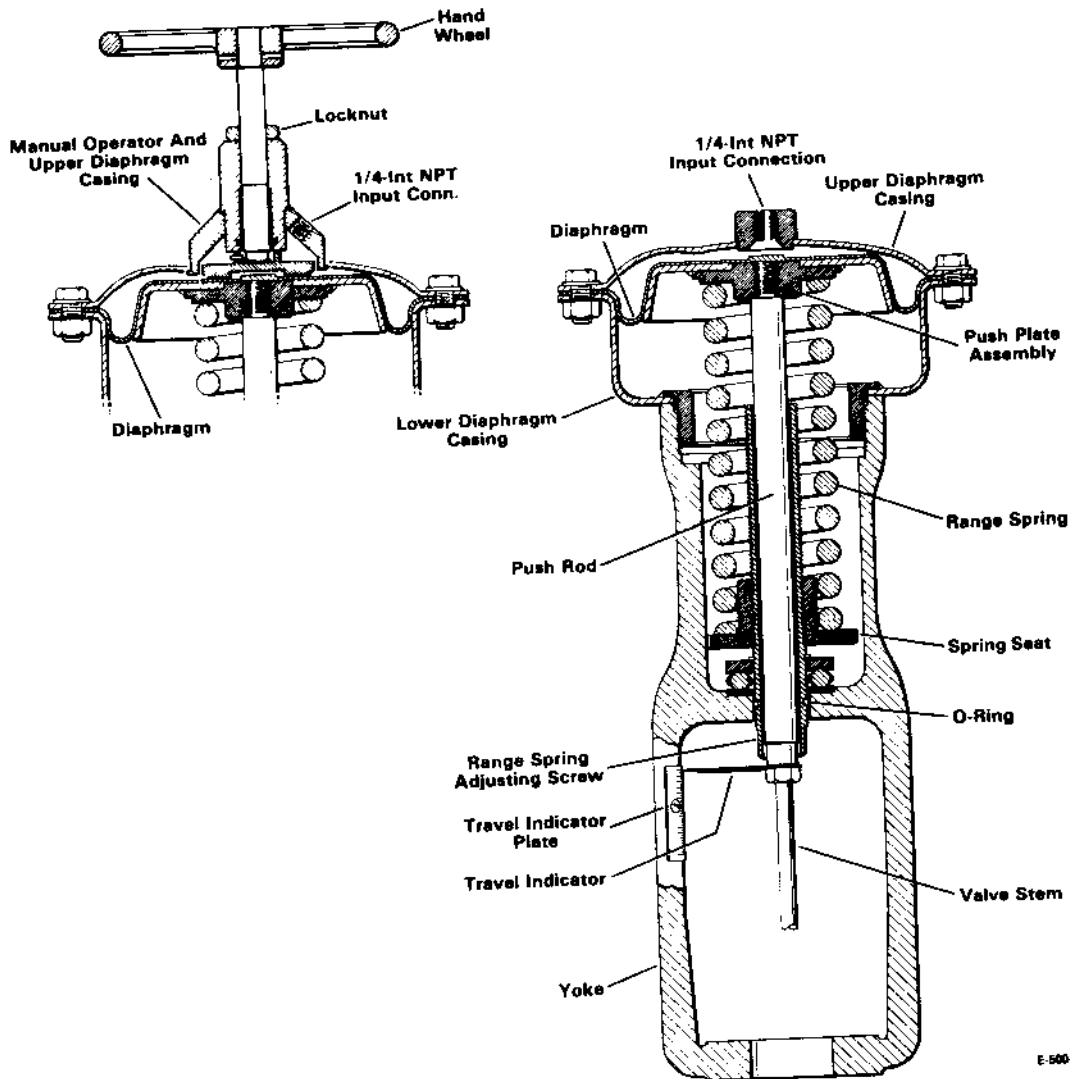

Figure 3. Air-to-Lower Actuator

1.1.3 Lin-E-Aire Actuator

There are two types of actuators, Air-to-Lower and Air-to-Raise. Selection depends upon the direction of push rod motion required in case of air supply failure.

Air-to-Lower type, Figure 3 — In this type of actuator, an increase in air pressure moves the push rod downward, compressing the spring. In the event of air failure, the push rod moves to its extreme upward position.

This actuator can also be supplied with a top mounted manual operator. The manual operator is often used as an adjustable travel stop. If it is used on

a push-to-close valve, full opening can be restricted by manually setting the operator at a required position. If used on a push-to-open valve, full closing can be restricted.

Air-to-Raise type, Figure 4 — In this type of actuator, an increase in air pressure moves the push rod upward, compressing the spring. In the event of air failure the push rod moves to its extreme downward position.

Thus, by selection of actuator and control valve plug action, either push-to-close or push-to-open, the control valve will either open or close on failure of air pressure to the actuator diaphragm.

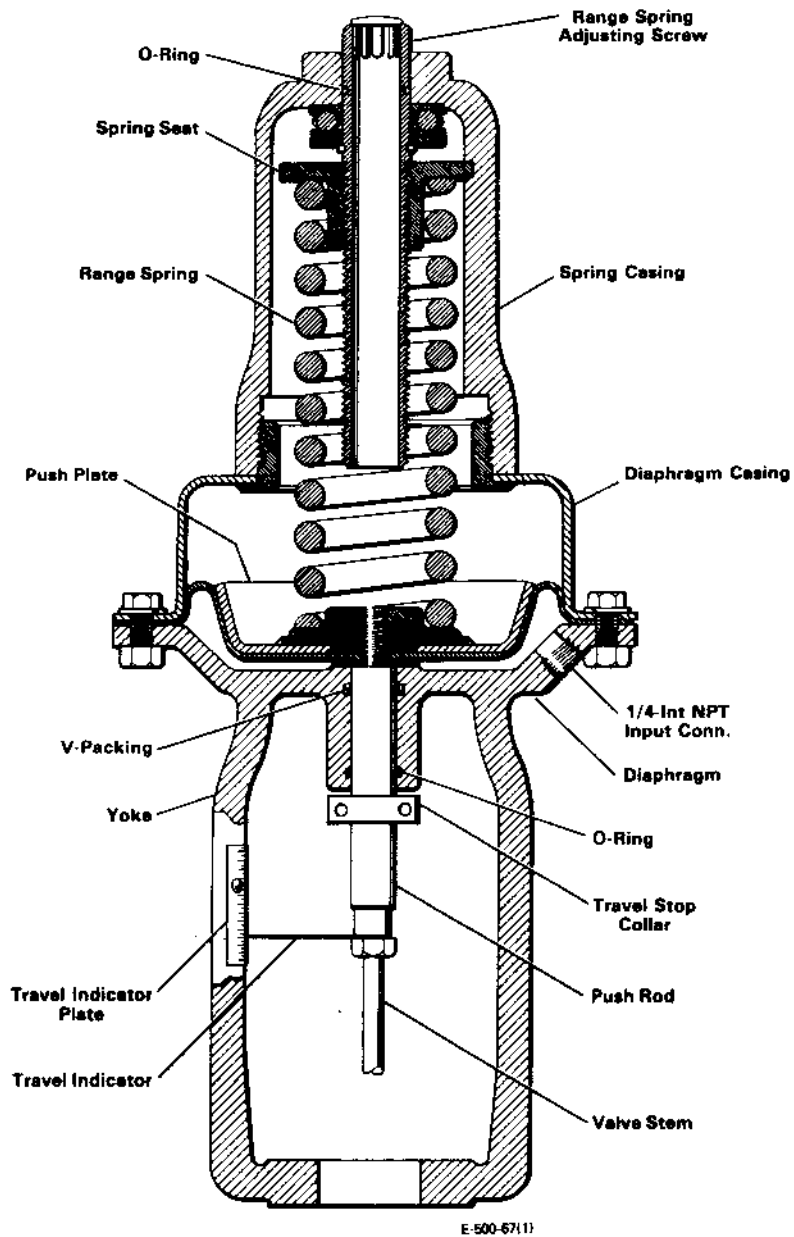

Figure 4. Air-to-Raise Actuator

INTRODUCTION

1.2 SERIAL AND CATALOG NUMBERS

The serial number stamped on the data plate consists of catalog number and a sequential identification number. The catalog number describes the construction of the valve and actuator. The data plate is attached to the actuator.

An X before the serial number indicates that the instrument has been built to meet a customer's special requirements.

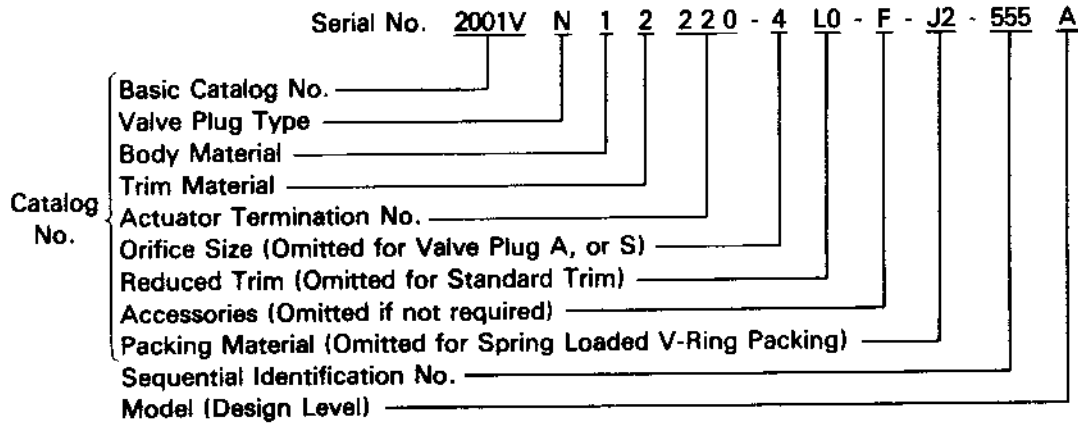

Sample Serial Numbers

- Valve with Linear Plug: 2001VA12230-F-J2-555A
- Valve with Linear Plug, Reduced Trim: 2001VA12230-LO-F-J2-555A
- Valve with Needle Plug: 2001VL12230-4F-J2-555A

BASIC CATALOG NO.

- 2000V – Hi-Flow Valve, 1/2 inch
Push-to-Close
- 2001V – Hi-Flow Valve, 3/4 inch
Push-to-Close
- 2002V – Hi-Flow Valve, 1 inch
Push-to-Close
- 2003V – Hi-Flow Valve, 1-1/4 inch
Push-to-Close
- 2004V – Hi-Flow Valve, 1-1/2 inch
Push-to-Close
- 2005V – Hi-Flow Valve, 2 inch
Push-to-Close
- 2010V – Hi-Flow Valve, 1/2 inch
Push-to-Open
- 2011V – Hi-Flow Valve, 3/4 inch
Push-to-Open
- 2012V – Hi-Flow Valve, 1 inch
Push-to-Open
- 2013V – Hi-Flow Valve, 1-1/4 inch
Push-to-Open
- 2014V – Hi-Flow Valve, 1-1/2 inch
Push-to-Open
- 2015V – Hi-Flow Valve, 2 inch
Push-to-Open

VALVE PLUG TYPE

- A – Linear
- L – Linear Needle
- N – Equal Percentage Needle
- S – Equal Percentage

BODY MATERIAL

- 1 – Ductile Iron
- 3 – Bronze
- 4 – Type 316 SST

TRIM MATERIAL

- 2 – Type 316 SST

ACTUATOR TERMINATION NO.

- 220 – Standard Air-to-Lower
20 in² Effective Area
- 221 – Senior Air-to-Lower
45 in² Effective Area
- 222 – Standard Air-to-Lower
45 in² Effective Area
- 223 – Senior Air-to-Lower
80 in² Effective Area
- 230 – Standard Air-to-Raise
20 in² Effective Area

INTRODUCTION

- 231 — Senior Air-to-Raise
45 in² Effective Area
- 233 — Standard Air-to-Raise
80 in² Effective Area

ORIFICE SIZE

- 2 — 1/8 inch
3 — 3/16 inch
4 — 1/4 inch
5 — 5/16 inch
6 — 3/8 inch
7 — 1/32 inch
8 — 1/16 inch
9 — 3/32 inch

REDUCED TRIM

- L0 — 3/4 to 1/2 inch (2001V)
L0 — 1 to 1/2 inch (2002V)
L1 — 1 to 3/4 inch (2002V)

ACCESSORIES

- A — Valve Positioner
C — Top Mounted Manual Operator
F — Extension Bonnet
M — Limit Switches
M1 - Dust Proof
M2 - Explosion Proof
M3 - Plug-in
N — Air Set Mounting
N103 - 1004F Air Set
N103 - 1004F Air Set with Gauge
P — Travel Limiter
Z — Special Operating Range

OPTIONAL PACKING MATERIAL

- J2 — Spring Loaded Graphite Packing
J3 — Lubricated Graphite Packing with Lubricator
J7 — TFE V-Ring Packing for Vacuum Service
J8 — Double TFE V-Ring Packing for Positive Pressure
J9 — Double TFE V-Ring Packing for Negative Pressure
J10 — Double TFE V-Ring Packing for Alternate Positive and Negative Pressures

EXAMPLE:

Serial No. 2001VA12230-F-J2-555A identifies a 3/4-inch push-to-close valve (2001V), with a linear valve plug (A). The body material is ductile iron (1), trim material is type 316 SST (2), and the actuator is

air-to-raise (230). The orifice size and reduced trim digits do not apply and are omitted from this serial number. The valve has an extension bonnet (F), and spring loaded graphite packing (J2). The sequential identification number is 555 and the design level is Model A.

1.3 TECHNICAL CHARACTERISTICS

VALVE BODY PRESSURE RATING

- Ductile Iron: 250 psig at 400°F
(1725 kPa at 204°C)
- Bronze: 250 psig at 400°F
(1725 kPa at 204°C)
- Type 316 SST: 300 psig at 400°F
(2070 kPa at 204°C)

AMBIENT TEMPERATURE LIMITS

–32°F min, 150°F max (–36°C, 66°C)

PROCESS TEMPERATURE LIMITS

–150°F (–66°C) min (with Extension Bonnet),
400°F (204°C) max

MAXIMUM ACTUATOR AIR PRESSURE

Refer to Table 1

MAXIMUM STROKE

Refer to Table 1

ACTUATOR MATERIALS

- Frame: Cast Iron, Baked Enamel Finish
Diaphragm Case: Steel, Baked Enamel Finish
Diaphragm: Buna-N-rubber, Nylon reinforced
Range Spring: Plated spring steel
Range Spring Seat: }
Adjusting Screw: } Plated cold rolled steel
Push Rod: }

VALVE MATERIALS

- Body: } Refer to Paragraph 1.2
Trim: }
Standard Packing: Three spring loaded TFE
V-Rings with wiper ring
Optional Packing: Refer to Paragraph 1.2
Packing Bonnet: Brass on ductile iron or bronze
body; type 316 SST on 316 SST
body

INTRODUCTION

Table 1. Maximum Air Supply Pressure and Maximum Stroke

Actuator Termination Number		Actuator Part No.		Max. Air Supply Pressure		Max. Stroke	
		Without Hand Wheel	With Hand Wheel	psig	kPa	Inches	mm
Air to Lower	220	15S620	—	100	700	1	25.4
	221	15S621	15S721	50	350	1	25.4
	222	15S622	15S722	100	700	1-1/2	38.1
	223	15S623	15S723	50	350	1-1/2	38.1
Air to Raise	230	15S630	—	100	700	1	25.4
	231	15S631	—	50	350	1	25.4
	233	15S633	—	50	350	1-1/2	38.1

2**INSTALLATION****2.1 MOUNTING**

Mount the control valve in a location where it will be accessible for servicing. The valve can be mounted in any position in the pipeline, but the preferred position is in a horizontal pipe run with the actuator perpendicular to the pipeline and above the pipe. The ambient temperature of the mounting location must be within the limits listed in **1.3 Technical Characteristics**.

Clearance should be left above and below the control valve to permit removal of actuator and valve plug. Figure 5 shows removal clearance that is required. Mounting dimensions for these valves are shown in Figures 6, 7, 8, 9 and 10.

Before mounting, inspect valve body ports. Make sure ports are clean and threaded connections have not been damaged.

Mount the valve in the pipe line with flow in the direction indicated by the arrow cast on the body.

Apply a suitable thread lubricant to the male pipe threads before putting the valve in the line.

2.2 PNEUMATIC CONNECTIONS

Connect the input pressure to the 1/4-inch Int NPT port on the top of an air-to-lower actuator or under the diaphragm casing on an air-to-raise actuator, Figure 6, 7 or 8. Either pipe or tubing may be used for the air line. The input pressure must not exceed the limits listed in **1.3 Technical Characteristics**.

When there is a long distance between the actuator and the control device which produces the input pressure, or when a large actuator size is required, there may be excessive transmission lag in the control signal. A Taylor valve Positioner, Catalog Number 100N, can be used to reduce the lag. If a valve positioner is furnished with the actuator, connections between the positioner and actuator are made at the factory. Refer to the valve positioner instructions for additional connection information.

INSTALLATION

VALVE SIZE	DIMENSION A LINE-AIRE ACTUATOR												DIMENSION B			
	Push-to-Close Actuator				Push-to-Close Actuator with Mandwheel				Push-to-Open Actuator				Plain Bonnet		Ext. Bonnet	
	Term No.	Plain Bonnet	Ext. Bonnet	Term No.	Plain Bonnet	Ext. Bonnet	Term No.	Plain Bonnet	Ext. Bonnet	Term No.	Plain Bonnet	Ext. Bonnet	Plain Bonnet	Ext. Bonnet	Plain Bonnet	Ext. Bonnet
1/2	220	24-1/2	29	---	---	---	230	24-3/4	29-1/4	---	---	230	24-3/4	29-1/4	9-7/8	14-3/8
	221	25-1/8	29-5/8	---	---	---	231	25-3/8	29-7/8	---	---	231	25-3/8	29-7/8	9-7/8	14-3/8
	222	27-1/4	31-3/4	---	---	---	233	29-7/8	34-3/8	---	---	233	29-7/8	34-3/8	9-7/8	14-3/8
3/4	220	24-1/2	29	---	---	---	230	24-3/4	29-1/4	---	---	230	24-3/4	29-1/4	10-3/4	15-3/4
	221	25-1/8	29-5/8	221(C)	30-7/8	35-3/8	231	25-3/8	29-7/8	---	---	231	25-3/8	29-7/8	10-3/4	15-3/4
	222	27-1/4	31-3/4	---	---	---	233	29-7/8	34-3/8	---	---	233	29-7/8	34-3/8	10-3/4	15-3/4
1	220	24-1/2	29	---	---	---	230	24-3/4	29-1/4	---	---	230	24-3/4	29-1/4	10-3/4	15-3/4
	221	25-1/8	29-5/8	---	---	---	231	25-3/8	29-7/8	---	---	231	25-3/8	29-7/8	10-3/4	15-3/4
	222	27-1/4	31-3/4	---	---	---	233	29-7/8	34-3/8	---	---	233	29-7/8	34-3/8	10-3/4	15-3/4
1-1/4	220	24-5/8	29-1/8	---	---	---	230	24-7/8	29-3/8	---	---	230	24-7/8	29-3/8	10-7/8	15-7/8
	221	25-1/4	29-3/4	---	---	---	231	25-3/4	30	---	---	231	25-3/4	30	10-7/8	15-7/8
	222	27-1/8	31-5/8	222(C)	33-1/8	37-5/8	233	29-7/8	34-3/8	---	---	233	29-7/8	34-3/8	10-7/8	15-7/8
1-1/2	220	25	32	---	---	---	230	25-1/4	32-1/4	---	---	230	25-1/4	32-1/4	12-3/8	19-3/8
	221	25-5/8	32-5/8	221(C)	31-1/4	36-1/4	231	25-7/8	32-7/8	---	---	231	25-7/8	32-7/8	12-3/8	19-3/8
	222	27-1/2	34-1/2	222(C)	33-1/2	40-1/2	233	30-1/4	37-1/4	---	---	233	30-1/4	37-1/4	12-3/8	19-3/8
2	220	25-1/4	32-1/4	---	---	---	230	25-1/2	32-1/2	---	---	230	25-1/2	32-1/2	12-1/2	19-1/2
	221	25-7/8	32-7/8	221(C)	33-3/4	40-3/4	231	26-1/8	33-1/8	---	---	231	26-1/8	33-1/8	12-1/2	19-1/2
	222	27-3/4	34-3/4	222(C)	36-3/8	43-3/8	233	30-1/2	37-1/2	---	---	233	30-1/2	37-1/2	12-1/2	19-1/2

INCHES	mm	INCHES	mm	INCHES	mm	INCHES	mm	INCHES	mm
9-7/8	250.83	25-1/2	647.70	30-1/2	774.70	30-1/2	774.70	34-3/4	882.65
10-3/4	273.05	25-5/8	650.88	30-3/4	781.05	30-3/4	781.05	35-1/4	895.35
10-7/8	276.23	25-3/4	654.05	30-7/8	784.23	30-7/8	784.23	35-3/8	898.53
12-3/8	314.33	25-7/8	657.23	31-1/4	793.25	31-1/4	793.25	35-3/4	908.05
12-1/2	317.50	26-1/8	663.58	31-1/2	800.10	31-1/2	800.10	36-1/8	917.58
14-3/8	365.13	27-1/8	688.98	31-5/8	803.28	31-5/8	803.28	36-3/8	923.93
15-3/4	400.05	27-1/4	692.15	31-3/4	806.45	31-3/4	806.45	37-1/4	946.15
15-7/8	403.23	27-1/2	698.50	32	812.80	32	812.80	37-1/2	952.50
19-3/8	482.13	27-3/4	704.85	32-1/4	819.15	32-1/4	819.15	37-5/8	956.68
19-1/2	495.30	29	736.60	32-1/2	825.50	32-1/2	825.50	38-1/4	971.55
24-1/2	622.30	29-1/8	739.78	32-5/8	828.68	32-5/8	828.68	38-1/2	977.90
24-5/8	625.48	29-1/4	742.95	32-7/8	835.03	32-7/8	835.03	40-1/4	1022.35
24-3/4	628.65	29-3/8	746.13	33-1/8	841.38	33-1/8	841.38	40-1/2	1028.70
24-7/8	631.83	29-5/8	752.48	33-1/2	850.90	33-1/2	850.90	40-3/4	1035.05
25	635.00	29-3/4	755.65	33-3/4	857.25	33-3/4	857.25	43-1/8	1095.38
25-1/8	638.18	29-7/8	758.83	34-1/4	869.95	34-1/4	869.95	43-3/8	1101.53
25-1/4	641.35	30	762.00	34-3/8	873.13	34-3/8	873.13		
25-3/8	644.53	30-1/4	768.35	34-1/2	876.30	34-1/2	876.30		

All dimensions in inches
For reference only;
not for construction.

8-506-350

Figure 5. Removal Clearance Required

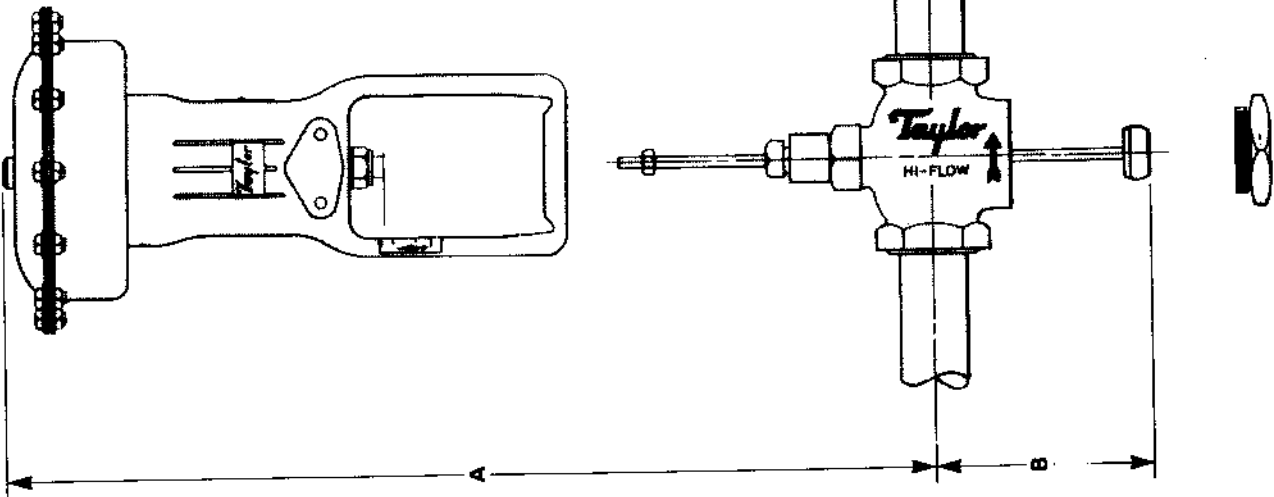

INSTALLATION

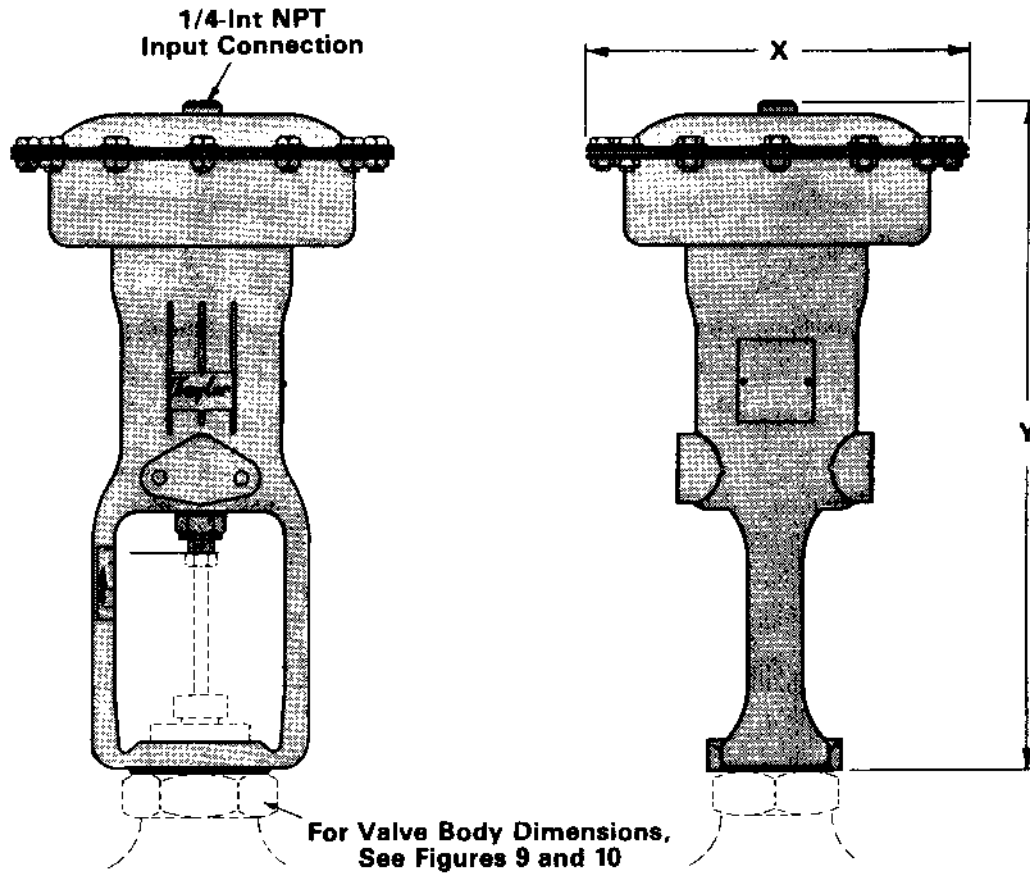

Actuator		Part No.	X	Y	No. of Bolts	Yoke Boss Hole Diam.
Type	Term No.					
Standard	220	15S620	7-3/4	15-7/8	10	1-1/2
	222	15S622	10-5/8	18-5/8	12	1-15/16
Senior	221	15S621	10-5/8	16-9/16	12	1-1/2
	223	15S623	13-3/8	20	18	1-15/16

INCHES	mm
1-1/2	38.10
1-15/16	49.21
7-3/4	196.85
10-5/8	269.88
13-3/8	339.73
15-7/8	403.23
16-9/16	420.69
18-5/8	473.08
20	508.00

All dimensions in inches.

For reference only;
not for construction

Figure 6. Mounting Dimensions for Air-to-Lower Actuator

INSTALLATION

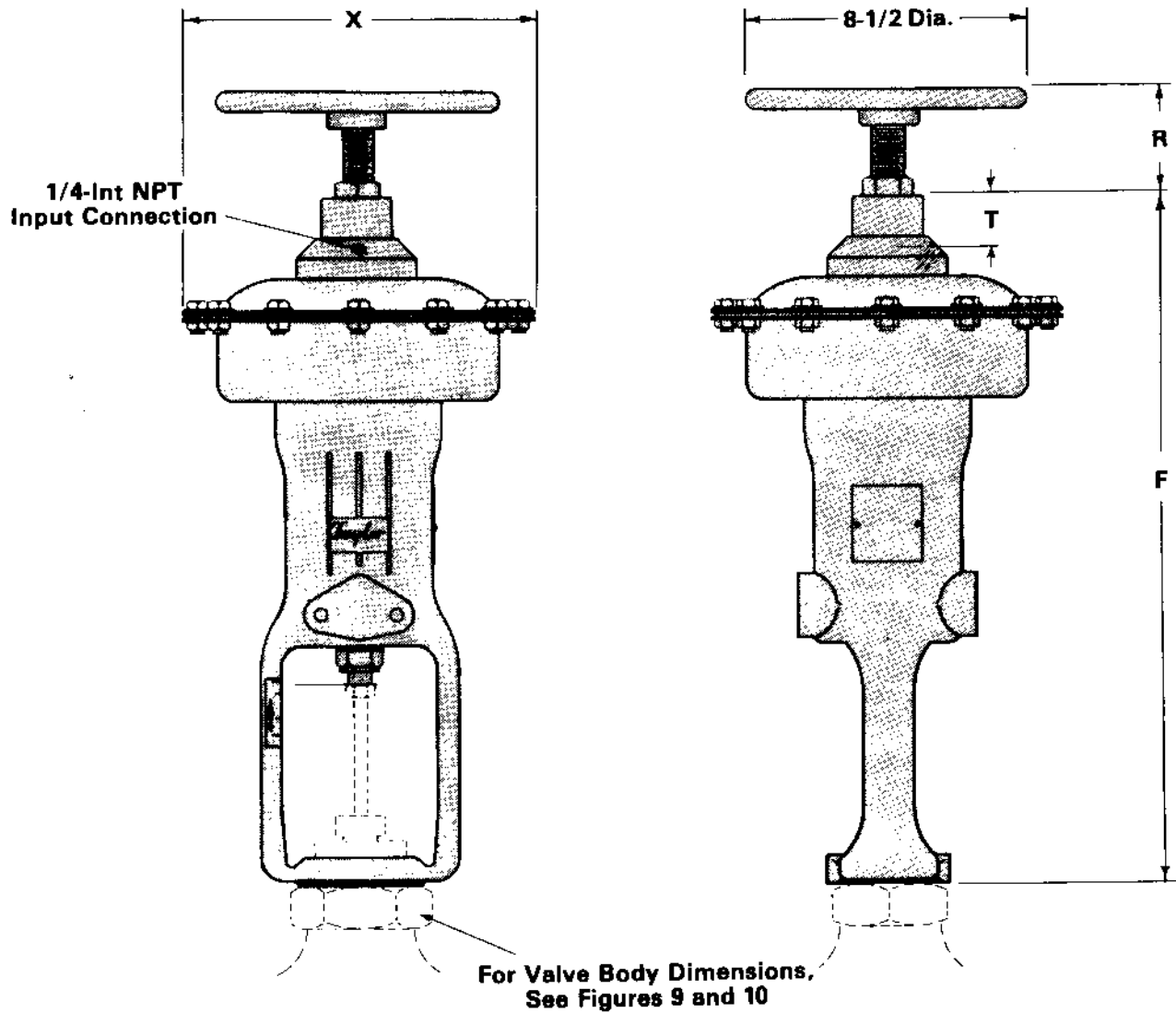

Actuator		Part No.	F	R (Max.)	T	X	No. of Bolts	Yoke Boss Hole Diam.
Type	Term. No.							
Standard	222	15S722	22-3/32	3-1/4	2-19/32	10-5/8	12	1-15/16
Senior	221	15S721	20-1/32	3-1/4	2-19/32	10-5/8	12	1-1/2
	223	15S723	24-1/8	4	3-9/32	13-3/8	18	1-15/16

All dimensions in inches.

For reference only;
not for construction

INCHES	mm
8-1/2	215.90
10-5/8	269.88
13-3/8	339.73
20-1/32	508.79
22-3/32	561.18
24-1/8	612.78

INCHES	mm
1-1/2	38.10
1-15/16	49.21
2-19/32	65.88
3-1/4	82.55
3-9/32	83.34
4	101.60

Figure 7. Mounting Dimensions for Air-to-Lower Actuator with Manual Operator (Accessory C)

INSTALLATION

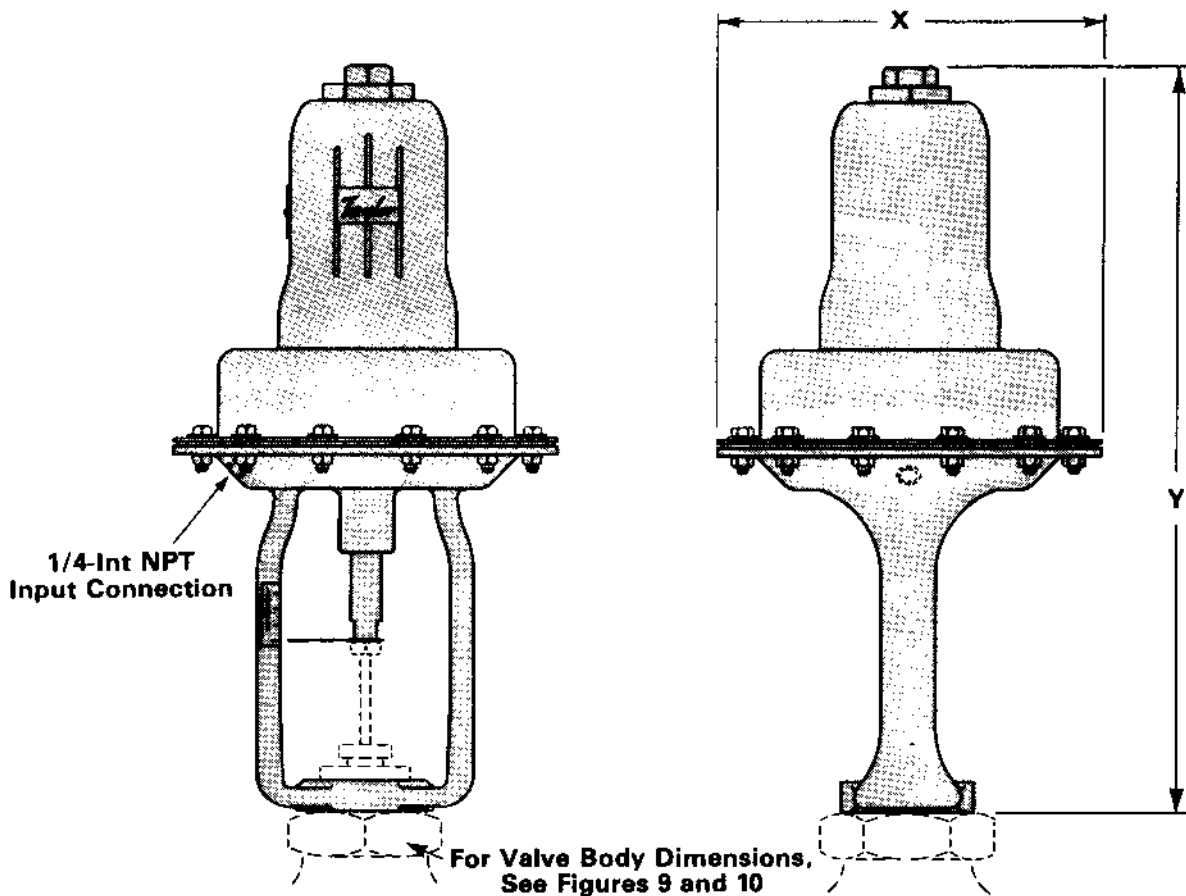

Actuator		Part No.	X	Y	No. of Bolts	Yoke Boss Hole Diam.
Type	Term No.					
Standard	230	15S630	7-3/4	17-3/16	10	1-1/2
Senior	231	15S631	10-5/8	17-13/16	12	1-1/2
	233	15S633	13-3/8	22-9/32	18	1-1/2

INCHES	mm
1-1/2	38.10
7-3/4	196.85
10-5/8	269.88
13-3/8	339.73
17-3/16	436.56
17-13/16	452.44
22-9/32	565.94

All dimensions in inches.

For reference only;
not for construction

Figure 8. Mounting Dimensions for Air-to-Raise Actuator

INSTALLATION

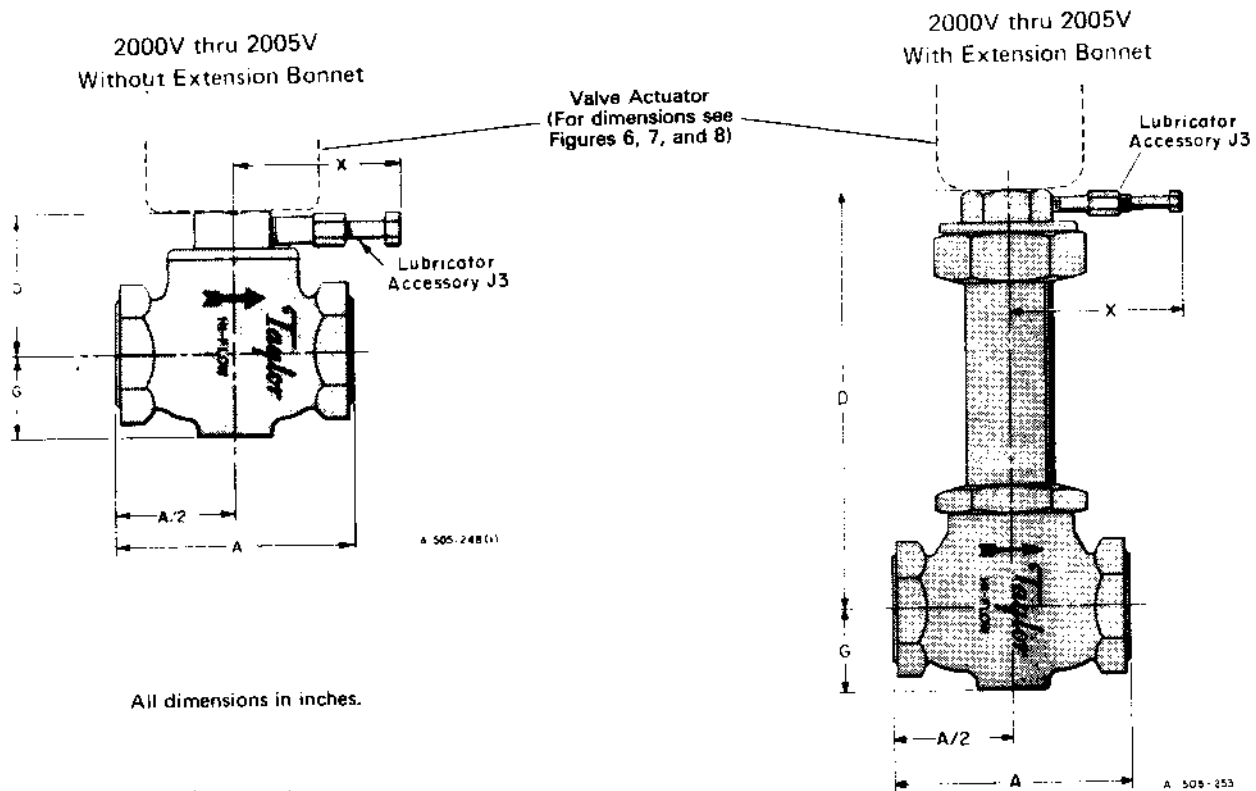

All dimensions in inches.

For reference only;
not for construction.

CATALOG NO.	VALVE SIZE	A		D		G	X
		Ductile Iron or Bronze Body	Type 316 SST Body	Without Extension	With Extension		
2000V	1/2"	3-3/4	4-3/16	2-9/16	7-1/16	1-3/8	4-7/8
2001V	3/4"	3-7/8	4-1/4	2-9/16	7-1/16	1-3/8	4-7/8
2002V	1"	4-3/4	5-1/4	3	7-1/2	1-5/8	4-7/8
2003V	1-1/4"	5	5-3/4	3-1/8	7-5/8	1-13/16	5-1/16
2004V	1-1/2"	5-1/2	6-1/8	3-1/2	10-1/2	2	5-1/16
2005V	2"	6-1/2	6-7/8	3-3/4	10-3/4	2-3/8	5-1/16

INCHES	mm	INCHES	mm	INCHES	mm
1/2	12.70	3	76.20	5-1/4	133.35
3/4	19.06	3-1/8	79.38	5-1/2	139.70
1	25.40	3-1/2	88.90	5-3/4	146.05
1-1/4	31.75	3-3/4	95.25	6-1/8	155.58
1-3/8	34.93	3-7/8	98.43	6-1/2	165.10
1-1/2	38.10	4-3/16	106.36	6-7/8	174.63
1-5/8	41.28	4-1/4	107.95	7-1/16	179.39
1-13/16	46.04	4-3/4	120.65	7-1/2	190.50
2	50.80	4-7/8	123.83	7-5/8	193.68
2-3/8	60.33	5	127.00	10-1/2	266.70
2-9/16	65.09	5-1/16	128.59	10-3/4	273.05

Figure 9. Mounting Dimensions for 2000V thru 2005V Hi-Flow Valves

INSTALLATION

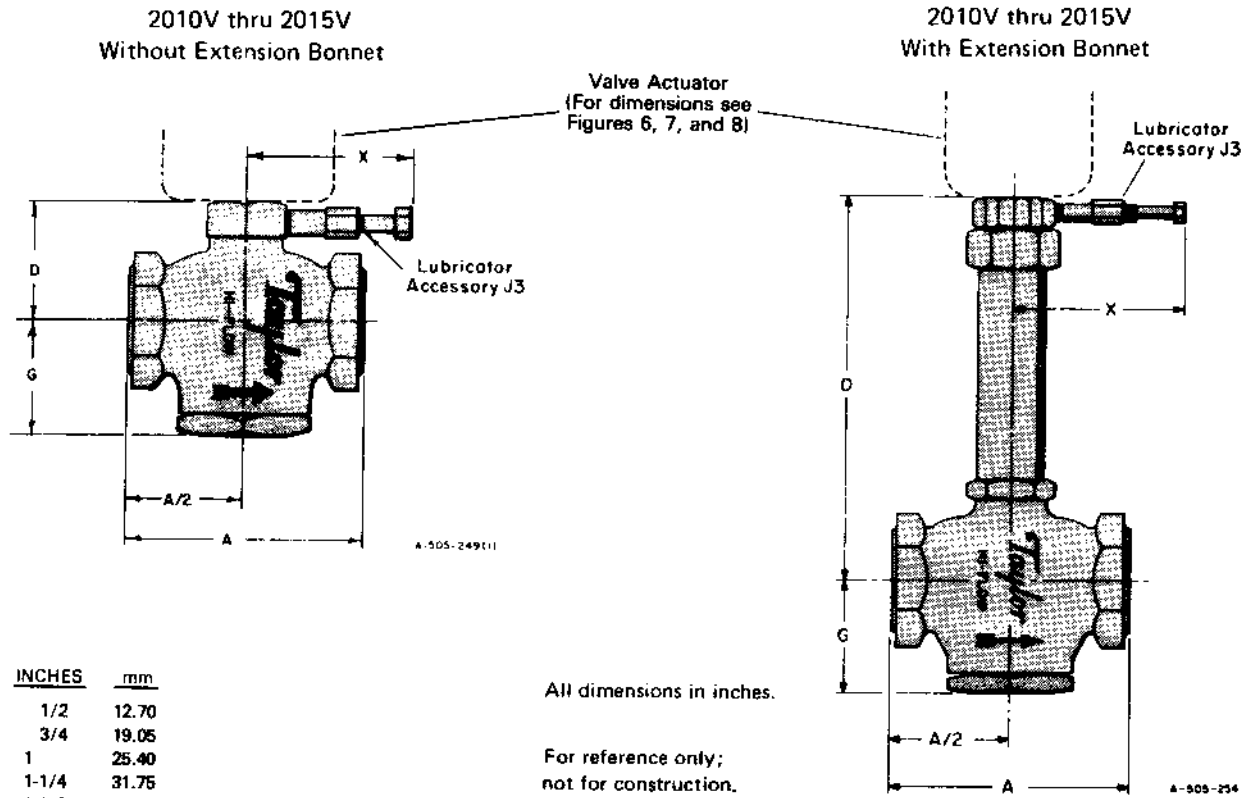

INCHES	mm
1/2	12.70
3/4	19.05
1	25.40
1-1/4	31.75
1-1/2	38.10
1-13/16	46.04
2	50.80
2-3/16	55.56
2-3/8	60.33
2-7/16	61.91
2-1/2	63.50
2-3/4	69.85
2-13/16	71.44
3	76.20
3-3/16	80.96
3-3/4	95.25
3-7/8	98.43
4-3/4	120.65
4-7/8	123.83
5	127.00
5-1/16	128.59
6-1/2	139.70
6-1/2	165.10
6-11/16	169.86
6-15/16	176.21
7	177.80
9-3/4	247.65
10-3/16	258.76

All dimensions in inches.

For reference only;
not for construction.

CATALOG NO.	VALVE SIZE	A	D		G	X
			Without Extension	With Extension		
2010V	1/2"	3-3/4"	2-3/16	6-11/16	1-13/16	4-7/8
2011V	3/4"	3-7/8	2-3/16	6-11/16	1-13/16	4-7/8
2012V	1"	4-3/4	2-7/16	6-15/16	2-3/16	4-7/8
2013V	1-1/4"	5	2-1/2	7	2-3/8	5-1/16
2014V	1-1/2"	5-1/2	2-3/4	9-3/4	2-13/16	5-1/16
2015V	2"	6-1/2	3-3/16	10-3/16	3	5-1/16

Figure 10. Mounting Dimensions for 2010V thru 2015V Hi-Flow Valves

OPERATION

3

OPERATION

3.1 CHECKING VALVE TRAVEL

The actuator spring has been selected to meet the requirements of the application and has been adjusted at the factory to the pressure range stamped on the data plate. The spring has a constant rate of compression, and adjustments shift the pressure span up or down to make stem travel coincide with this pressure range. When in service, the actuator should yield the required travel when pressure range stamped on data plate is applied. This diaphragm pressure range is generally 3 to 15 psi (20 to 100 kPa), but other ranges may be used.

When the actuator is completely installed and connected to the control device, it should be checked with normal working line pressure conditions for correct travel. Apply the pressure range listed on the data plate to the actuator. Note that travel indicator should have moved the distance marked on indicator plate, Figure 11.

The pressure drop across the valve body ports has a direct effect on the actual operating pressure range. In some instances, the valve operating range may be different from the indicated range. This is because the pressure conditions in the valve body are different from those originally specified and for which the control valve has been set at the factory. If this

difference is small, a spring adjustment is all that is required to obtain correct operating range, refer to 3.2 Adjusting Actuator Range.

3.2 ADJUSTING ACTUATOR RANGE

NOTE

When using this procedure, be sure that the valve is operating under normal line pressure conditions. Refer to 4.7 Adjusting Actuator Range-Shop Procedure if valve is not in pipe line. If necessary, make test hookup as shown in Figure 26.

3.2.1 Air-to-Lower Actuator

1. Slowly increase input pressure until stem just begins to move. Stem motion can be accurately detected by feeling stem or push rod as pressure is applied.

WARNING

If valve is used for steam service or where line process is hot, use visual means of detecting movement to avoid injury.

2. Note input pressure at which stem moves.

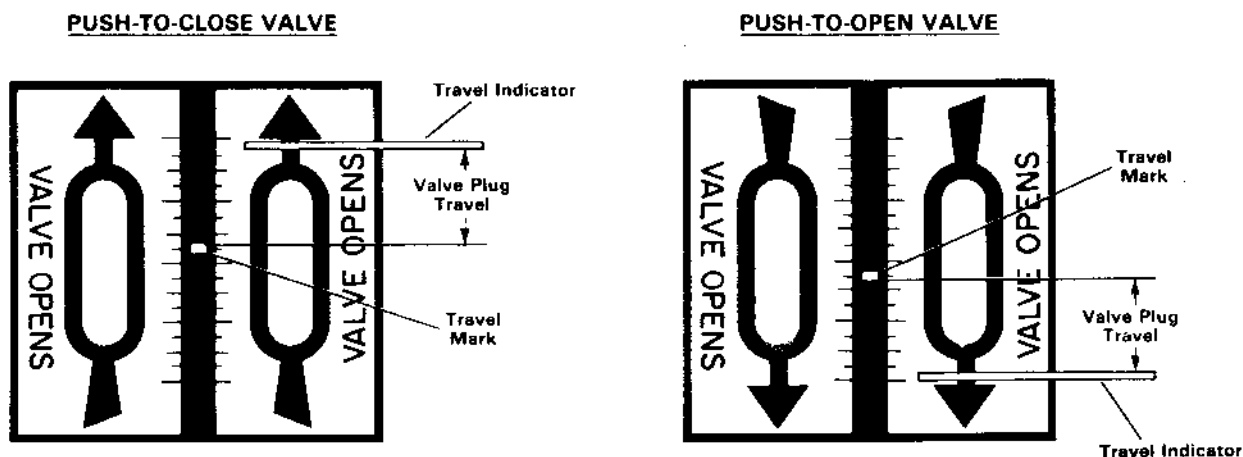

A-505-355

Figure 11. Travel Indicator Plate Showing Valve Plug Travel

3. If input pressure is not the same as lower range value on data plate, spring adjusting screw must be adjusted.

If pressure is high, turn adjusting screw, Figure 12, counterclockwise as viewed from the valve top.

If pressure is low, turn adjusting screw clockwise as viewed from the valve top.

4. Release input pressure and repeat Steps 1, 2 and 3 until valve stem moves at the lower range value.

3.2.2 Air-to-Lower Actuator with Manual Operator

1. Loosen locknut under hand wheel, Figure 3 and turn hand wheel counterclockwise to relieve all force on diaphragm.
2. Slowly increase input pressure until stem just begins to move. Stem motion can be accurately

detected by feeling stem or push rod as pressure is applied.

WARNING

If valve is used for steam service or where line process is hot, use visual means of detecting movement to avoid injury.

3. Note input pressure at which stem moves.
4. If input pressure is not the same as lower range value on data plate, spring adjusting screw must be adjusted.

If pressure is high, turn adjusting screw, Figure 12, counterclockwise as viewed from the valve top.

If pressure is low, turn adjusting screw clockwise as viewed from the valve top.

5. Release input pressure and repeat Steps 2, 3 and 4 until valve stem moves at the lower range value.

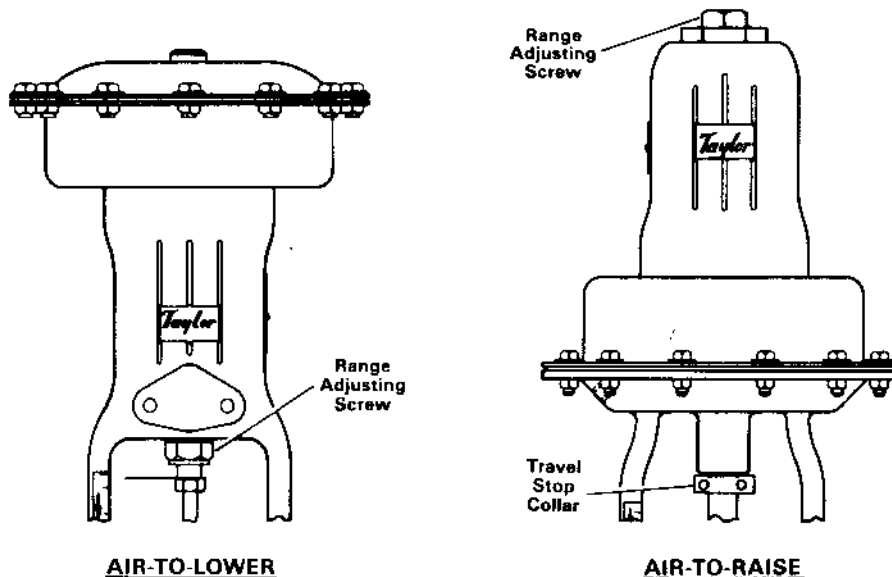

E 500 76

Figure 12. Adjusting Actuator Range

OPERATION

6. Turn hand wheel clockwise to required setting and tighten locknut under hand wheel.

3.2.3 Air-to-Raise Actuator

1. Loosen the four set screws on travel stop collar, Figure 12, collar should move freely on push rod.
2. Slowly increase input pressure until stem just begins to move. Stem motion can be accurately detected by feeling stem or push rod as pressure is applied.

WARNING

If valve is used for steam service or where line process is hot, use visual means of detecting movement to avoid injury.

3. Note input pressure at which stem moves.

4. If input pressure is not the same as lower range value on data plate, spring adjusting screw must be adjusted.

If pressure is high, turn adjusting screw clockwise as viewed from the valve top.

If pressure is low, turn adjusting screw counterclockwise as viewed from the valve top.

5. Release input pressure and repeat Steps 2, 3 and 4 until valve stem moves at lower range value.
6. Apply the upper range value input pressure stamped on data plate. Slide travel stop collar up on push rod right to yoke and tighten the four set screws.

4

MAINTENANCE

4.1 TEST EQUIPMENT AND TOOLS REQUIRED

The only test equipment required for valve and actuator maintenance is an air supply source, gage and regulator. The tools required are shown in Table 2.

4.2 DISASSEMBLING VALVE

The control valve has only three parts which normally require maintenance. They are the packing, valve plug and stem assembly, and seat ring. Use this procedure to disassemble the valve and check these components for wear or damage. It is recommended that the packing always be replaced following disassembly of the valve.

cedure to disassemble the valve and check these components for wear or damage. It is recommended that the packing always be replaced following disassembly of the valve.

WARNING

Before attempting any maintenance on control valve, make sure valve has been relieved of all pressure.

Table 2. Tools Required

Valve Size	Tool	Size	Use
All	Screwdriver	3/16-inch	Travel Indicator Plate
		1/4-inch	
	Open End Wrenches	1/2-inch 9/16-inch 5/8-inch	Diaphragm Casing Mounting Screw and Nut
		7/8-inch 1-1/4-inch	Range Spring Adjusting Screw
		9/16-inch 11/16-inch	Actuator Push Rod
		1/2-inch	Valve Stem Locknut
		31/32-inch	Valve Packing Nut
		1-13/16-inch 2-13/16-inch	Bonnet, Push-to-Close Valve
		1-3/4-inch 2-1/4-inch	Bonnet, Push-to-Open Valve
		1/2" & 3/4" 1" 1-1/4" 1-1/2" 2"	2-3/8-inch 2-5/8-inch 2-7/8-inch 3-1/8-inch 3-5/8-inch
All	Hammer	—	Valve Mounting Nut
	Drive Pin	—	
	Seat Ring Tool Taylor Part No. 153S22 (Figure 13)	—	Valve Seat Ring
	Valve Packing Tool Taylor Part No. 153P9 (Figure 15)	—	TFE V-Ring Valve Packing

MAINTENANCE

1. Measure length of thread showing below stem locknut, Figure 14 and record this dimension. Loosen stem locknut.
2. On push-to-close valves with air-to-raise actuator or push-to-open valves with air-to-lower actuator, apply just enough air pressure to actuator to move valve plug off valve seat, approximately 1/8 inch (3.2 mm). Loosen valve mounting nut.

On push-to-close valves with air-to-lower actuator or push-to-open valves with air-to-raise actuator, it is not necessary to apply air to the actuator to loosen valve mounting nut.

3. Shutoff pressure to actuator and disconnect air line.

WARNING

Make sure all pressure has been relieved from actuator.

4. Unscrew mounting nut.
5. Unscrew valve stem and plug assembly from push rod by rotating actuator. It may be necessary to use pliers to hold valve stem. If necessary, grip stem near threads to avoid scoring lower portion of stem.
6. Lift actuator off valve body.
7. Remove stem locknut and loosen packing nut.
8. Unscrew bonnet from valve body. On push-to-close valves, the valve plug and stem assembly may come out with bonnet.
9. Unscrew packing nut and remove packing follower from bonnet. Remove valve plug and stem assembly. On push-to-open valves, remove bottom plug and pull valve plug and stem assembly from bottom of valve body. This may damage the packing and the packing should be replaced.

NOTE

Check valve plug and stem assembly as well as seat rings for damage. If stem valve plug or seat ring is badly scratched or nicked they must be replaced when

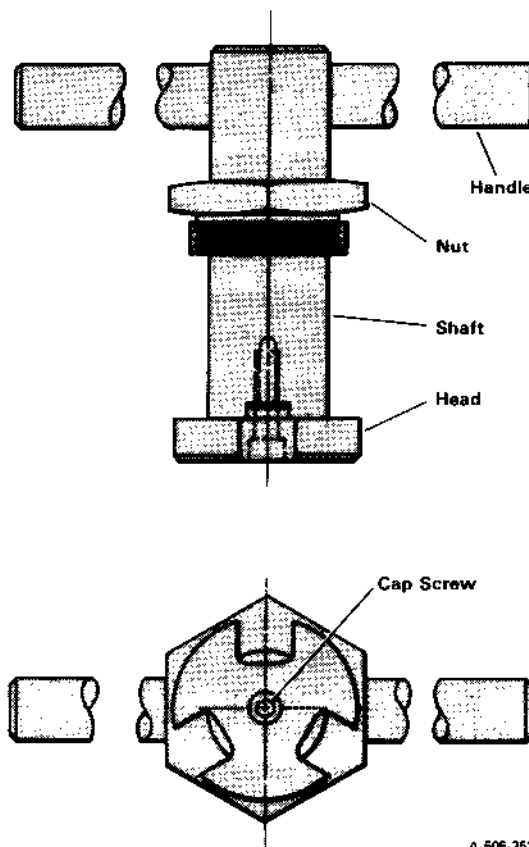

Figure 13. Taylor Seat Ring Removal Tool, Part No. 153S22

valve is reassembled. Refer to 4.3 **Assembling Valve.**

CAUTION

When performing Step 10, be careful not to scratch the surface that guides the valve stem.

10. Form a wire hook and pull packing from bonnet, or push a rod through to force the parts out of upper part of bonnet.
11. The spring and washer can be removed by turning bonnet upside down and tapping or shaking it.
12. If seat ring is to be replaced, remove ring using Taylor tool Part Number 153S22, Figure 13.
13. Thoroughly clean bonnet after removing internal parts.

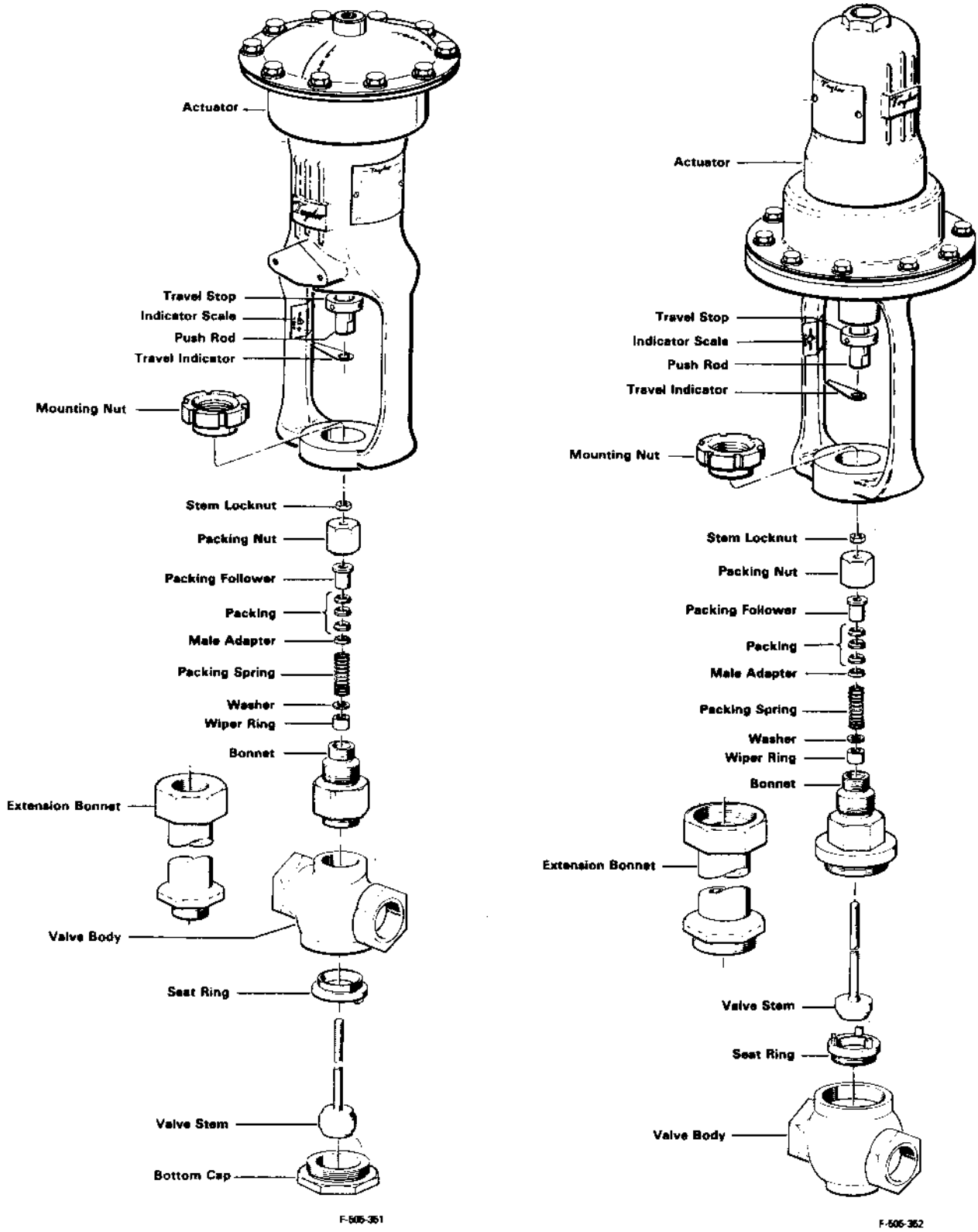

Figure 14. Exploded View of Control Valve

MAINTENANCE

4.3 ASSEMBLING VALVE

After disassembling the valve and checking for worn or damaged parts in 4.2 **Disassembling Valve**, use this procedure to install the required new parts and assemble the valve.

1. If new seat ring, Figure 14, is to be installed, proceed as follows:
 - a. Apply a coating of Plastic Lead Seal, Taylor Part Number 325M36 (John Crane Insoluble Number 2), to threads of new seat ring.
 - b. Using seat ring tool, Figure 13, screw seat ring into valve body. Tighten seat ring to torque specifications listed in Table 3.

NOTE

When installing valve plug and stem assembly in bonnet it is recommended that packing be replaced.

2. Install new valve plug and stem assembly in bonnet as follows:
 - a. **Push-to-close valve**, Figure 14 — Insert stem into bonnet. Coat threads of bonnet with Plastic Lead Seal and screw bonnet into valve body. Tighten bonnet to torque specifications listed in Table 3.
 - b. **Push-to-open valve** — Insert stem through bottom of valve. Apply coating of Plastic Lead Seal to threads of bottom cap and assemble to bottom of valve. Apply coating of Plastic Lead Seal to threads of bonnet, slide bonnet over valve stem and screw into

valve body. Tighten cap and bonnet to torque specifications listed in Table 3.

3. Install new packing as follows:
 - a. **TFE Packing** — Use packing tool, Taylor Part Number 153P9, Figure 15, to prevent damaging packing. Slide tool over valve stem threads. Lightly coat TFE packing with silicone grease, Taylor Part Number 353M27 (Dow Corning Corp. Number 17 compound). Slide packing over tool on stem in the order shown in Figure 16 or 19 thru 22, choosing the view that applies to the packing being replaced.

CAUTION

Never pound TFE packing to force it into bonnet.

- b. **Graphite Packing** — Install packing in the order shown in Figure 17 or 18, choosing the view that applies to the packing being replaced. Be careful not to damage packing on valve stem threads.
4. Install packing nut on valve stem as follows:
 - a. **TFE packing** — Tighten packing nut as far as it will go.
 - b. **Graphite packing** — Tighten packing nut finger tight. Make further adjustments to stop leakage after flow has been established.

Table 3. Torque Values for Assembling Valve

VALVE PART	VALVE SIZE	TORQUE	
		Foot-lbs	Newton-Metre
Seat Ring	1/2, 3/4, 1 & 1-1/4	100-125	135.6-169.5
	1-1/2 & 2	125-150	169.5-203.4
Bonnet Push-to-Close	1/2 & 3/4	100-125	135.6-169.5
	1 & 1-1/4	125-150	169.5-203.4
	1-1/2 & 2	200-250	271.2-339
Bonnet, Push-to-Open	ALL	100-125	135.6-169.5
Bottom Cap	1/2 & 3/4	100-125	135.6-169.5
	1 & 1-1/4	125-150	169.5-203.4
	1-1/2 & 2	200-250	271.2-339

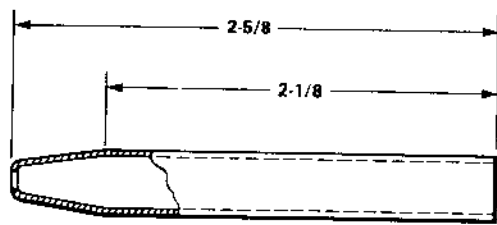

A-505-354

Figure 15. Taylor Valve Packing Tool,
Part No. 153P9

5. Install stem locknut and travel indicator on valve stem.
6. Mount actuator on valve body, install valve mounting nut over stem assembly as stem passes thru boss.

CAUTION

When performing Step 7, be careful not to rotate valve plug on seat ring.

7. Using dimension recorded in 4.2 Disassembling Valve Step 1 as reference, screw valve plug and stem assembly into push rod as follows:

- a. **Push-to-close valve with air-to-lower actuator** — Screw stem assembly into push rod by turning actuator until valve plug is about 1/4-inch (6.4 mm) above valve seat, tighten valve mounting nut.
- b. **Push-to-close valve with air-to-raise actuator** — Move valve plug to its fully closed position. Screw stem assembly into push rod by turning actuator until a gap of 1/8-inch (3.2 mm) exists between bonnet and actuator. Apply pressure to actuator until this gap closes and then tighten valve mounting nut. Remove pressure from actuator.
- c. **Push-to-open valve with air-to-raise actuator** — Move valve plug to its fully opened position. Screw stem assembly into push rod by turning actuator until bonnet is tight to actuator and then tighten valve mounting nut.

- d. **Push-to-open valve with air-to-lower actuator** — Place a mark on the push rod next to the actuator. Move valve plug to its fully closed position. Screw stem assembly into push rod by turning actuator until the push rod is pulled down 3/16-inch (4.8 mm). It may be necessary to grip valve stem with pliers, to keep valve plug from turning on seat. Then tighten valve mounting nut.

8. Align travel indicator with scale and tighten stem locknut.

9. Refer to 4.4 Adjusting Valve Plug Travel.

4.4 ADJUSTING VALVE PLUG TRAVEL

The purpose of this procedure is to adjust the length of valve stem engagement in the push rod so that the travel indicator is at the travel marks on the indicator plate when valve is fully closed.

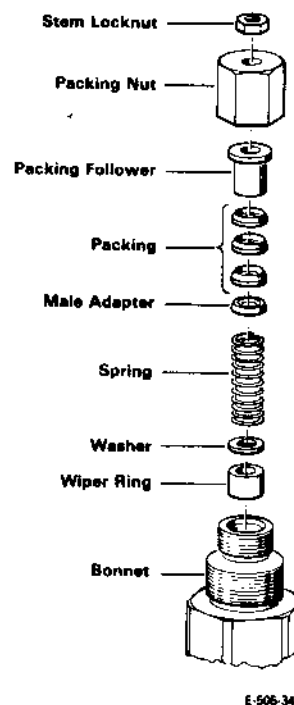

E-506-343

Figure 16. Standard Packing Spring Loaded
TFE V-Ring

MAINTENANCE

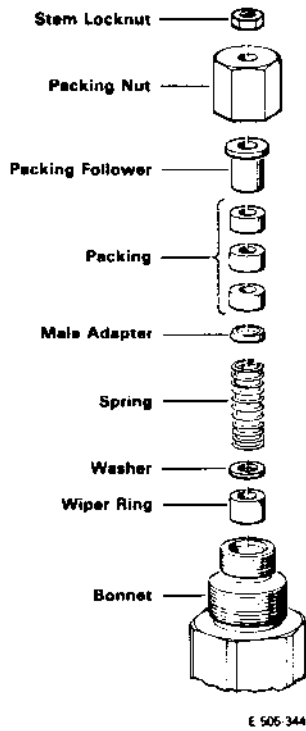

Figure 17. Optional Packing Catalog No. Code J2 Spring Loaded Graphite

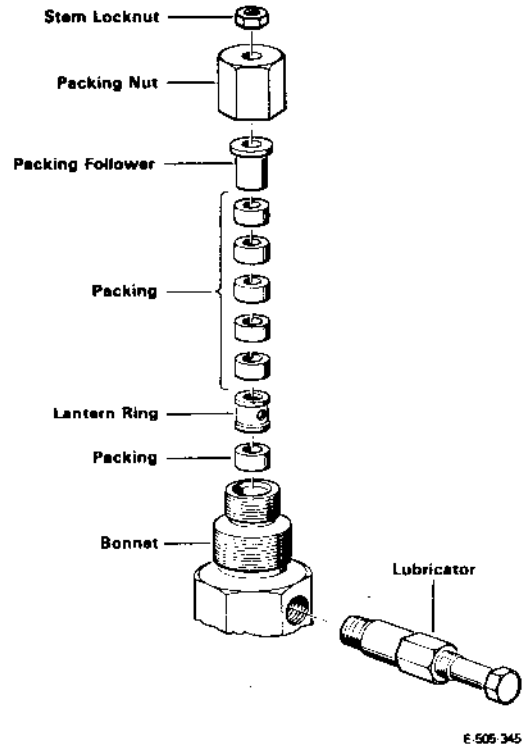

Figure 18. Optional Packing Catalog No. Code J3 Lubricated Graphite with Lubricator

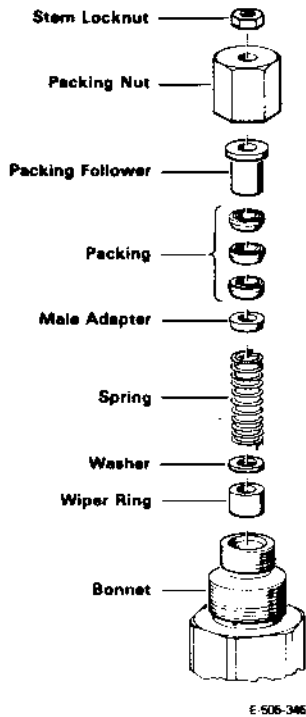

Figure 19. Optional Packing Catalog No. Code J7 TFE V-Ring for Vacuum Service

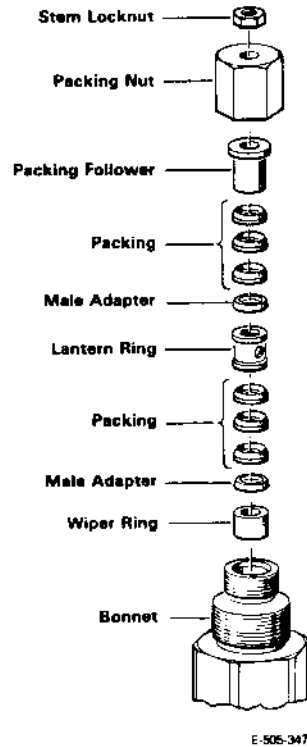

Figure 20. Optional Packing Catalog No. Code J8 Double TFE V-Ring for Positive Pressure

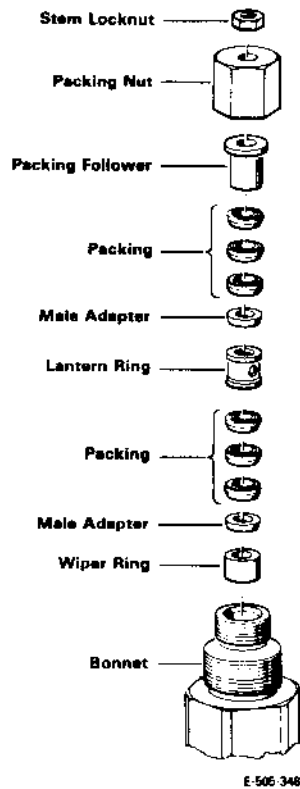

Figure 21. Optional Packing Catalog No. Code J9 Double TFE V-Ring for Negative Pressure

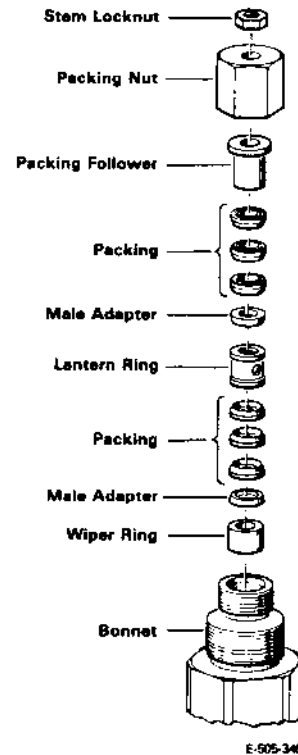

Figure 22. Optional Packing Catalog No. Code J10 Double TFE V-Ring for Alternate Positive and Negative Pressure

4.4.1 Push-to-Close Valve with Air-to-Lower Actuator

1. Apply air pressure to actuator to fully close valve and note location of travel indicator.
2. If indicator is not at travel marks on plate, Figure 11, measure distance between indicator and mark.

CAUTION
Do not make any adjustments when valve plug is on its seat.

3. Vent all pressure from actuator.
4. Loosen stem locknut, Figure 23. Grip valve stem near threads, and turn stem to move valve plug the distance measured in Step 2.
5. Position indicator toward travel indicator plate and tighten valve stem locknut.

6. Repeat Steps 1 thru 5 until travel indicator is at travel marks when valve is fully closed.

NOTE

If pressure range required to obtain full valve plug travel does not agree with range stamped on data plate, refer to 3.2 Adjusting Actuator Range.

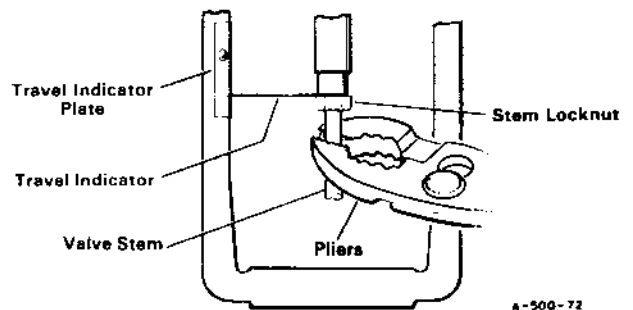

Figure 23. Adjusting Valve Plug Travel

MAINTENANCE

4.4.2 Push-to-Close Valve with Air-to-Raise Actuator or Push-to-Open Valve with Air-to-Lower Actuator

1. Apply air pressure to actuator to fully open valve and note location of travel indicator.
2. If indicator is not at travel marks on plate, Figure 11, measure distance between indicator and mark.

CAUTION

Do not make any adjustment when valve plug is on its seat.

3. Loosen stem locknut, Figure 23. Grip valve stem near threads, and turn stem to move valve plug the distance measured in Step 2.
4. Position indicator toward travel indicator plate and tighten valve stem locknut.
5. Vent all pressure from actuator.
6. Repeat Steps 1 thru 5 until travel indicator is at travel marks when valve is fully opened.

NOTE

If pressure range required to obtain full valve plug travel does not agree with range stamped on data plate, refer to **3.2 Adjusting Actuator Range**.

4.5 REPLACING ACTUATOR DIAPHRAGM

4.5.1 Air-to-Lower Actuator

1. Isolate or bypass the control valve in pipe line.
2. Shut off pressure to actuator and disconnect air line.
3. Turn range spring adjusting screw counterclockwise to relieve all spring compression.

WARNING

If all spring compression is not relieved, serious injury can occur when removing upper diaphragm casing.

4. Loosen and remove all diaphragm casing mounting screws, nuts and washers, Figure 24.

5. Lift off upper diaphragm casing from actuator assembly.
6. Remove old diaphragm and discard.
7. Install upper diaphragm casing with new diaphragm on actuator assembly. Fasten with bolts, nuts and washers removed in Step 4.
8. Reconnect pipe or tubing to pressure connection in upper diaphragm casing.
9. Readjust actuator travel, refer to **3.2 Adjusting Actuator Range**.

4.5.2 Air-to-Lower Actuator with Manual Operator

1. Isolate or bypass the control valve in pipe line.
2. Shutoff pressure to actuator and disconnect air line.
3. Turn manual operator hand wheel counterclockwise to relieve all pressure on diaphragm.
4. Turn range spring adjusting screw counterclockwise to relieve all spring compression.

WARNING

If all spring compression is not relieved, serious injury can occur when removing manual operator and upper diaphragm casing.

5. Loosen and remove all diaphragm casing mounting screws, nuts and washers, Figure 24.
6. Lift off manual operator and diaphragm casing from actuator assembly.
7. Remove old diaphragm and discard.
8. Install manual operator and diaphragm casing with new diaphragm on actuator assembly. Fasten with bolts, nuts and washers removed in Step 5.
9. Reconnect pipe or tubing to pressure connection in manual operator housing.
10. Readjust actuator travel, refer to **3.2 Adjusting Actuator Range**.

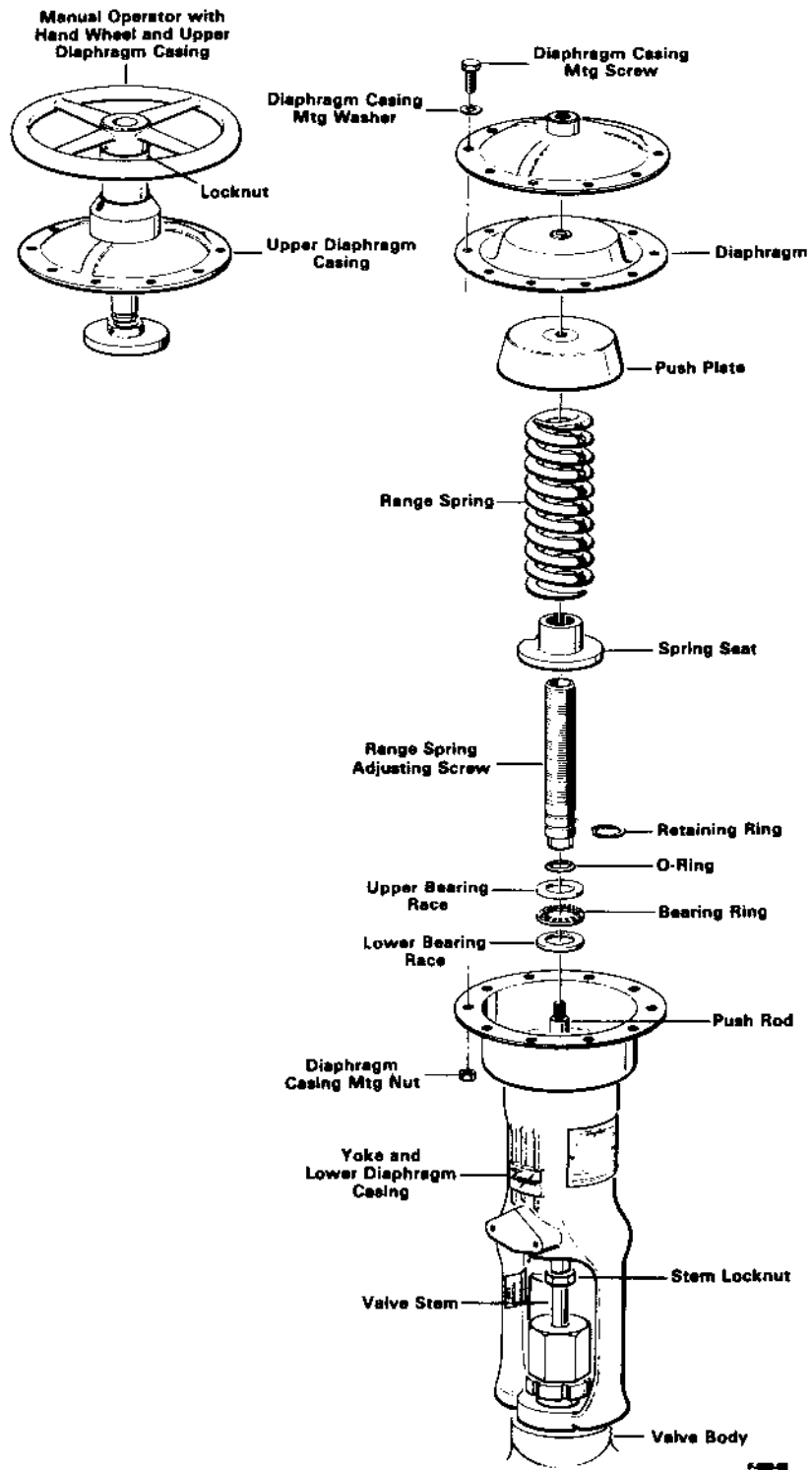

Figure 24. Exploded View of Air-to-Lower Actuator

MAINTENANCE

4.5.3 Air-to-Raise Actuator

1. Isolate or bypass the control valve in pipe line.
2. Shutoff pressure to actuator and disconnect air line.
3. Turn range spring adjusting screw clockwise to relieve all spring compression.

WARNING

If all spring compression is not relieved, serious injury can occur when removing spring and diaphragm casing.

4. Loosen and remove all diaphragm casing mounting screws, nuts and washers, Figure 25.
5. Lift off spring and diaphragm casing from actuator assembly.
6. Remove old diaphragm and discard.
7. Install spring and diaphragm casing with new diaphragm on actuator assembly. Fasten with bolts, nuts and washers removed in Step 4.
8. Reconnect pipe or tubing to pressure connection in yoke.
9. Readjust actuator travel, refer to 3.2 Adjusting Actuator Range.

4.6 CHANGING ACTUATOR RANGE SPRING

4.6.1 Air-to-Lower Actuator

1. Isolate or bypass the control valve in pipe line.
2. Shutoff pressure to actuator and disconnect air line.
3. Turn range spring adjusting screw counterclockwise to relieve all spring compression.

WARNING

If all spring compression is not relieved, serious injury can occur when removing upper diaphragm casing.

4. Loosen and remove all diaphragm casing mounting screws, nuts and washer, Figure 24.

5. Lift off upper diaphragm casing and diaphragm from actuator assembly.
6. Loosen valve stem locknut just enough to unscrew push rod with push plate from valve stem.

CAUTION

Do not rotate valve plug on seat ring. It may be necessary to use pliers to hold valve stem. If necessary grip stem near threads to avoid scoring stem.

7. Remove push rod and push plate with range spring from actuator assembly.
8. Install new range spring with push rod and push plate in actuator assembly.
9. Screw push rod on to valve stem to top of stem locknut and tighten locknut.
10. Install diaphragm casing with diaphragm on actuator assembly. Fasten with the bolts, nuts and washers removed in Step 4.
11. Reconnect pipe or tubing to pressure connection in upper diaphragm casing.
12. Readjust actuator travel, refer to 3.2 Adjusting Actuator Range.

4.6.2 Air-to-Lower Actuator with Manual Operator

1. Isolate or bypass the control valve in pipe line.
2. Shutoff pressure to actuator and disconnect air line.
3. Turn manual operator hand wheel counterclockwise to relieve all pressure on diaphragm.
4. Turn range spring adjusting screw counterclockwise to relieve all spring compression.

WARNING

If all spring compression is not relieved, serious injury can occur when removing manual operator and upper diaphragm casing.

5. Loosen and remove all diaphragm casing mounting screws, nuts and washers, Figure 24.

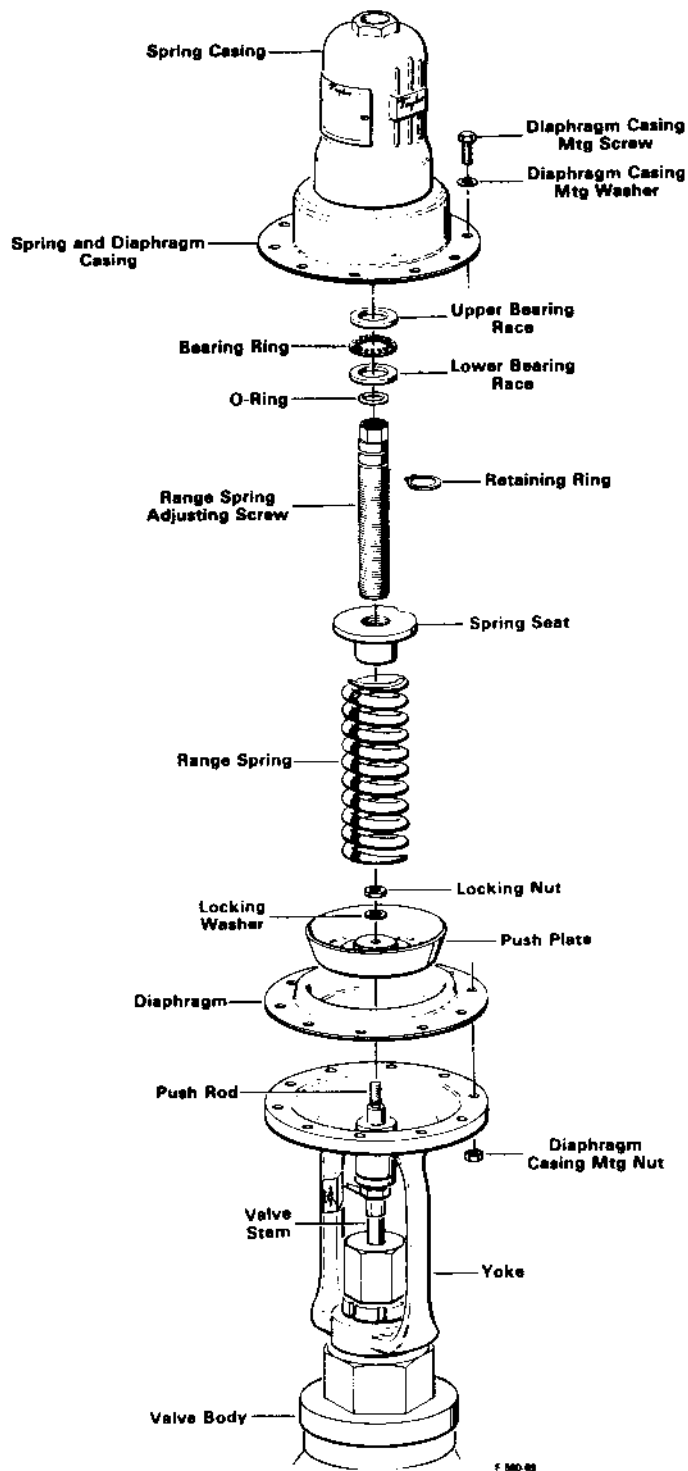

Figure 25. Exploded View of Air-to-Raise Actuator

MAINTENANCE

6. Lift off manual operator and diaphragm casing with diaphragm from actuator assembly.
7. Loosen valve stem locknut just enough to unscrew push rod with push plate from valve stem.

CAUTION

Do not rotate valve plug on seat ring. It may be necessary to use pliers to hold valve stem. If necessary grip stem near threads to avoid scoring stem.

8. Remove push rod and push plate with range spring from actuator assembly.
9. Install new range spring with push rod and push plate in actuator assembly.
10. Screw push rod on to valve stem to top of stem locknut and tighten locknut.
11. Install manual operator and diaphragm casing with diaphragm on actuator assembly. Fasten with bolts, nuts and washers removed in Step 5.
12. Reconnect pipe or tubing to pressure connection in manual operator housing.
13. Readjust actuator travel, refer to **3.2 Adjusting Actuator Range**.

4.6.3 Air-to-Raise Actuator

1. Isolate or bypass the control valve in pipe line.
2. Shutoff pressure to actuator and disconnect air line.
3. Turn range spring adjusting screw clockwise to relieve all spring compression.

WARNING

If all spring compression is not relieved, serious injury can occur when removing spring casing.

4. Unscrew spring casing with adjusting screw from diaphragm casing, Figure 25.
5. Remove old range spring and install new spring.
6. Screw spring casing with adjusting screw onto diaphragm casing.
7. Reconnect pipe or tubing to pressure connection in yoke.
8. Readjust actuator travel, refer to **3.2 Adjusting Actuator Range**.

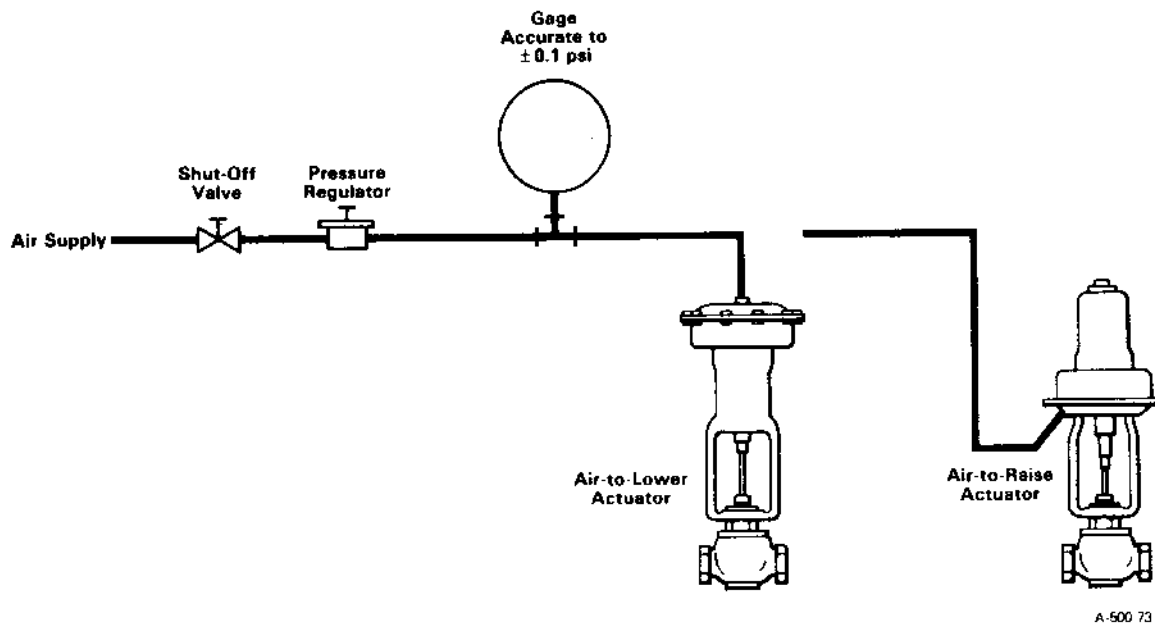

A-500 73

Figure 26. Test Hookup

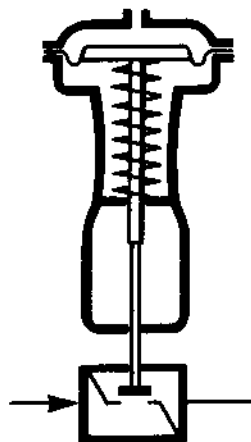

E-500-74

Figure 27. Valve with Air-to-Lower Actuator Showing Air-to-Close (ATC) Action

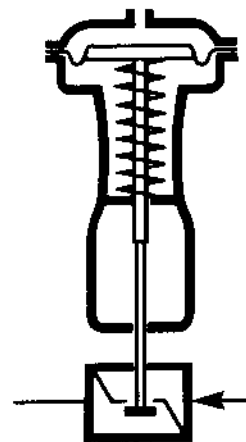

E-500-74(A)

Figure 28. Valve with Air-to-Lower Actuator Showing Air-to-Open (ATO) Action

4.7 ADJUSTING ACTUATOR RANGE-SHOP PROCEDURE

NOTE

Make test hookup as shown in Figure 26. When using this procedure the valve should be out of the pipe line or there should be no pressure in the line. Pipe line pressure will cause inaccurate spring adjustments.

4.7.1 Air-to-Lower Actuator with Push-to-Close Valve (ATC), Figure 27

1. Slowly increase input pressure until stem just begins to move. Stem motion can be accurately detected by feeling stem or push rod as pressure is applied.
2. Note input pressure at which stem moves.
3. If input pressure is not the same as lower range value on data plate, spring adjusting screw must be adjusted.

If pressure is high, turn adjusting screw, counter-clockwise as viewed from the valve top, Figure 12.

If pressure is low, turn adjusting screw clockwise as viewed from the valve top.

4. Release input pressure and repeat Steps 1, 2 and 3 until valve stem moves at the lower range value.

4.7.2 Air-to-Lower Actuator with Push-to-Open Valve (ATO), Figure 28

1. Determine input pressure at which stem should just begin to move from Figures 29a, 29b or 29c. Select the figure which covers the actuator termination number shown on the data plate under serial number.

Example:

Serial number on data plate reads 2012VA12222, which is a 1" size valve with an actuator termination number 222. Assume that the valve spring has been selected for use on a maximum differential pressure of 100 psig (690 kPa). Using Figure 29b, we can determine that valve stem movement should begin when actuator input reaches 5 psig (34 kPa) \pm 0.2 psig (1.4 kPa).

2. Slowly increase input pressure until stem begins to move. Stem motion can be accurately detected by feeling stem or push rod as pressure is applied.

MAINTENANCE

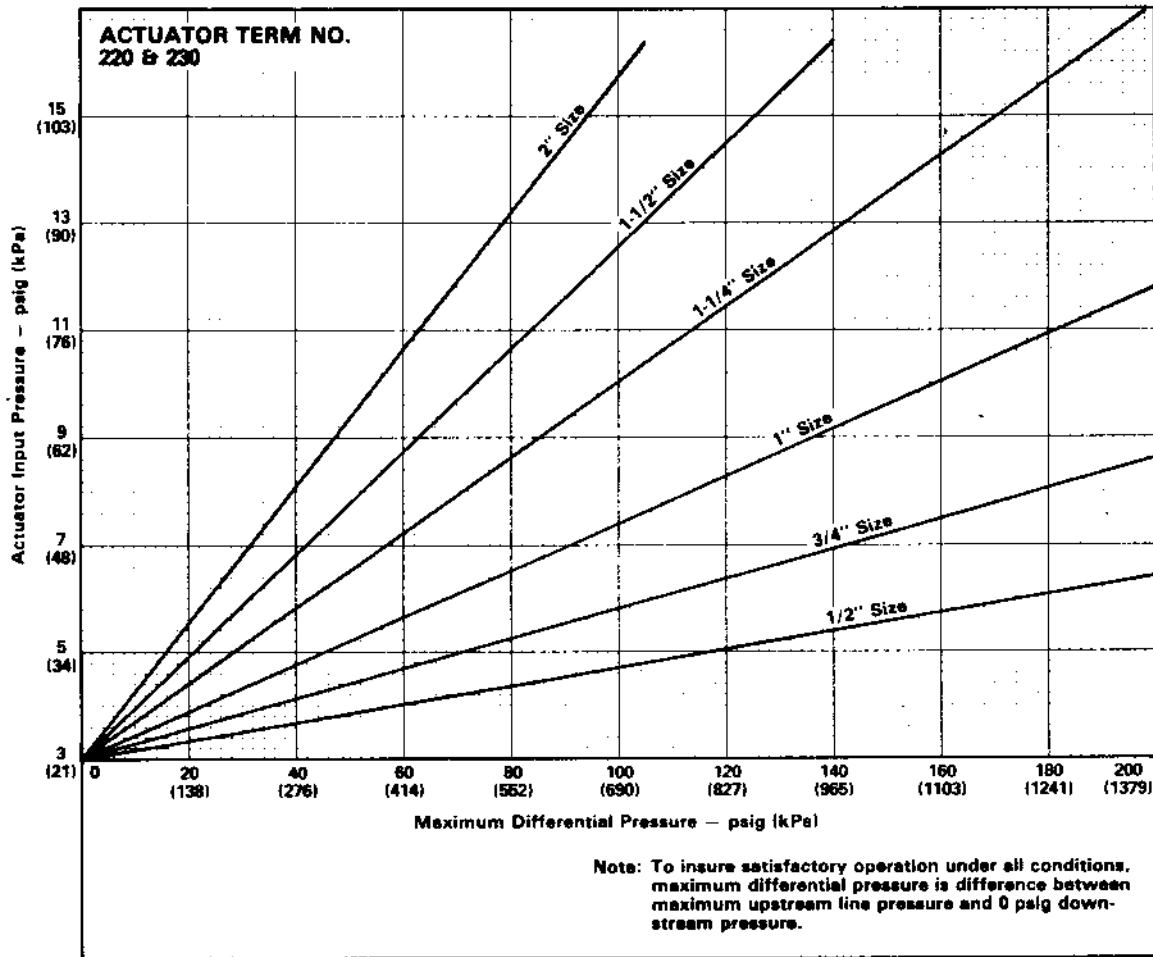

Figure 29a. Actuator Input Pressure Versus Maximum Differential Pressure for Termination Nos. 220, 230 (20 Sq. In. Std)

- Note input pressure at which stem just begins to move.
- If input pressure is not as found in Step 1, spring adjusting screw must be adjusted.

If pressure is high, turn adjusting screw counterclockwise as viewed from the valve top.

If pressure is low, turn adjusting screw clockwise as viewed from the valve top.
- Release input pressure and repeat Steps 2, 3 and 4 until valve stem moves at the pressure found in Step 1.

4.7.3 Air-to-Lower Actuator with Operator

- Loosen manual operator locknut, Figure 3, and turn hand wheel counterclockwise to relieve all force on diaphragm.
- Actuators with air-to-close valves, perform steps in 4.7.1 Air-to-Lower Actuator with Push-to-Close Valve (ATC).

Actuators with air-to-open valves, perform steps in 4.7.2 Air-to-Lower Actuator with Push-to-Open Valve (ATO).
- At end of adjustment procedure, turn hand wheel clockwise to required setting and tighten locknut under hand wheel.

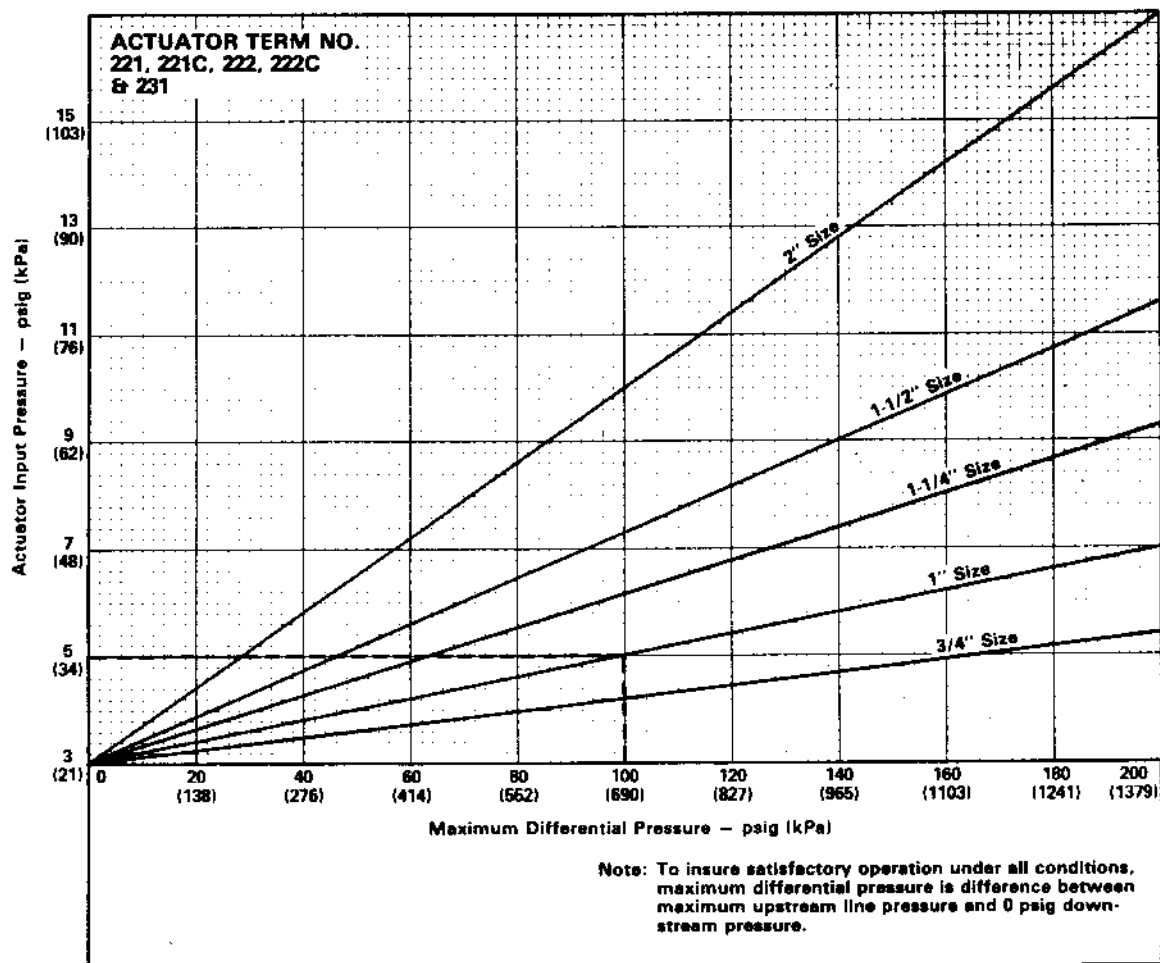

Figure 29b. Actuator Input Pressure Versus Maximum Differential Pressure for Termination Nos. 221, 221C, 231 (45 Sq. In. Senior), 222, 222C (45 Sq. In. Std)

4.7.4 Air-to-Raise Actuator with Push-to-Close Valve (ATO), Figure 30

1. Determine input pressure at which stem just begins to move from Figures 29a, 29b, or 29c. Select the figure which covers the actuator termination number shown on data plate under serial number.

Example:

Serial number on data plate reads 2002VA12231, which is a 1" size valve with an actuator termination number 231. Assume that the valve spring has been selected for use on a maximum differential pressure of 100 psig (690 kPa). Using Figure 29b we can determine that valve stem movement should begin when actuator input reaches 5 psig (34 kPa) \pm 0.2 psig (1.4 kPa).

2. Loosen the four set screws on travel stop collar, collar should move freely on push rod, Figure 12.
3. Slowly increase input pressure until stem just begins to move. Stem motion can be accurately detected by feeling push rod as pressure is applied.
4. Note input pressure at which stem moves.
5. If input pressure is not as found in Step 1, spring adjusting screw must be adjusted.

If pressure is high, turn adjusting screw clockwise as viewed from the valve top.

If pressure is low, turn adjusting screw counter-clockwise as viewed from the valve top.

MAINTENANCE

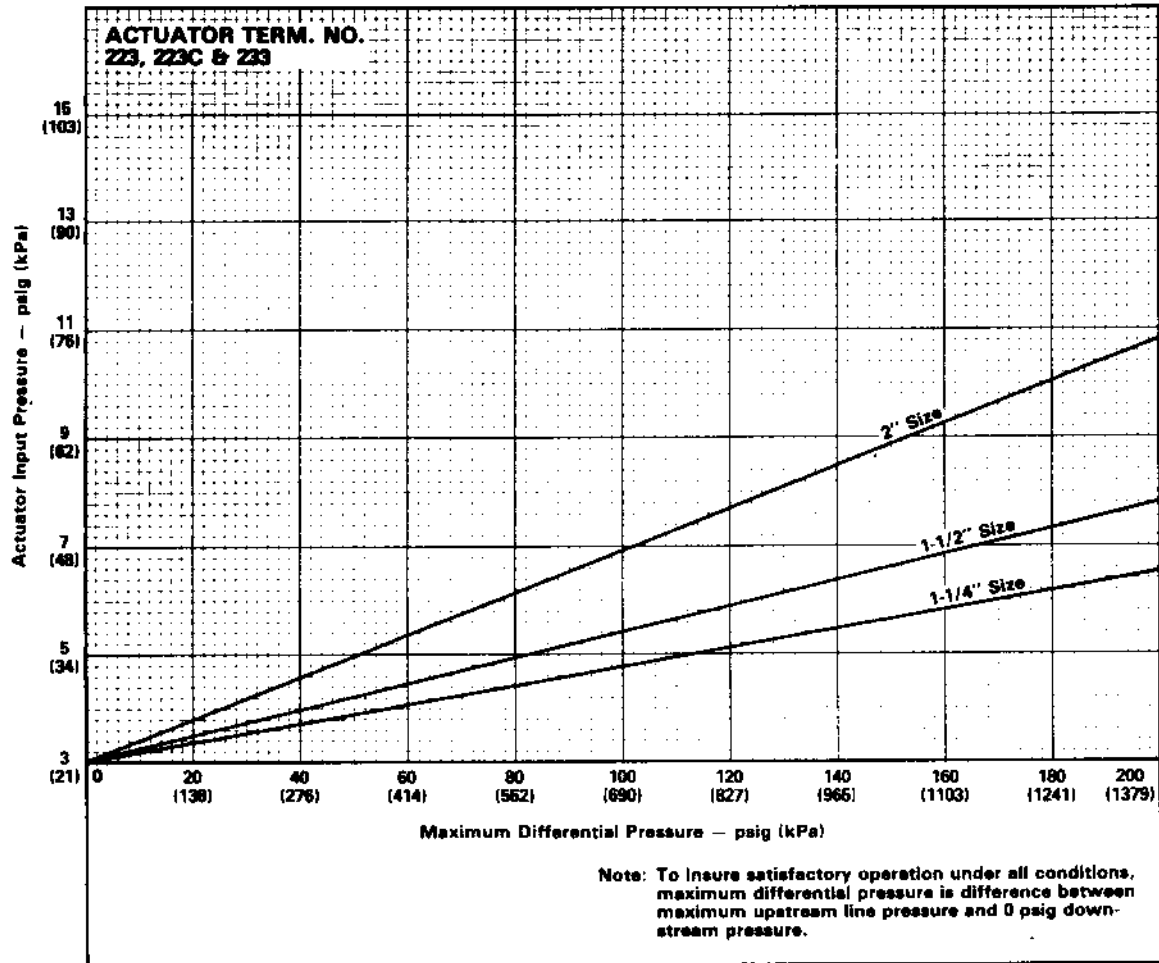

E-500-79A

Figure 29c. Actuator Input Pressure Versus Maximum Differential Pressure for Termination Nos. 223, 223C, 233 (80 Sq. In. Senior)

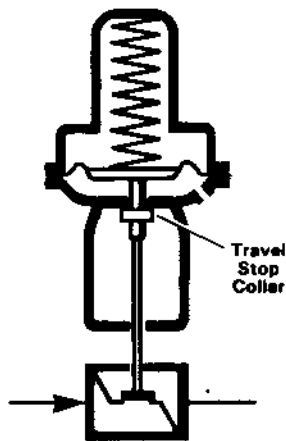

E-500-76

Figure 30. Valve with Air-to-Raise Actuator Showing Air-to-Open (ATO) Action

6. Release input pressure and repeat Steps 3, 4 and 5 until valve stem just begins to move at the pressure found in Step 1.
7. Determine span from range stamped on data plate. Add span to the value determined in Step 1 and apply this input pressure to actuator. Slide travel stop collar up on push rod tight against yoke and tighten the four set screws.