



The COMMANDER 350 can be configured and made ready for operation in three easy steps. This 'Getting Started' guide provides an overview of these steps and, where necessary, refers to the relevant section of the manual.

**Step 1 – Decide on the Application Template and the Output Configuration required**

**Step 2 – Connect the process inputs and outputs**

**Step 3 – Power up the instrument, set the template number and the output configuration details**

*Your COMMANDER 350 is now ready for operation*

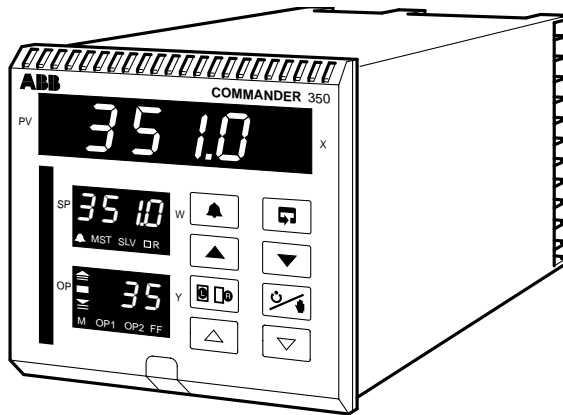

**Step 1 – Application Template and Output Configuration**

- Choose the Template which best suits your application from the list in Table A, located on the rear fold-out.
- Choose the Control Output Type required from the list of options in Table B on the rear foldout.

**Step 2 – Electrical Connections**

Using the labels on the back of the instrument as a guide, connect the process inputs, outputs and power supplies. Refer to Section 5.2 of this manual (Electrical Installation) for more information.

*Continued...*



Step 3 – Setting the Parameters (Fig. GS.1)

(A) Power-up the instrument. Press the [ ] and [ ] keys simultaneously and hold for 3 seconds to advance directly to Level 6 – Basic Configuration.

(B) Set the appropriate application template, output type and control action. Use the [ ] key to advance between frames and upper [ ] and [ ] keys to adjust the default values – see Section 4.2 for further information.

\* **Note.** When the output type has been selected, the available inputs and outputs default to the settings shown in Table B on the rear fold-out.

(C) If you are not using 4 to 20mA inputs, then select Level 7 using the upper [ ] and [ ] keys and set up Analog Inputs I/P1 to I/P3 to suit your process – see Section 4.3.

(D) Controller templates only:

Select Level 2 using the upper [ ] and [ ] keys and set the tune parameters:

- **Analog or Motorized Valve Control** – set the Proportional, Integral and Derivative terms.
- **Time Proportioning Control** – set the Cycle Time, Hysteresis and P, I & D Terms
- **Heat/Cool Outputs** – set the points at which the Output 1 and Output 2 become active.

(E) Press [ ] to return to the Operating displays.

(F) Adjust the set point to the required value.

Your COMMANDER 350 is now in operation

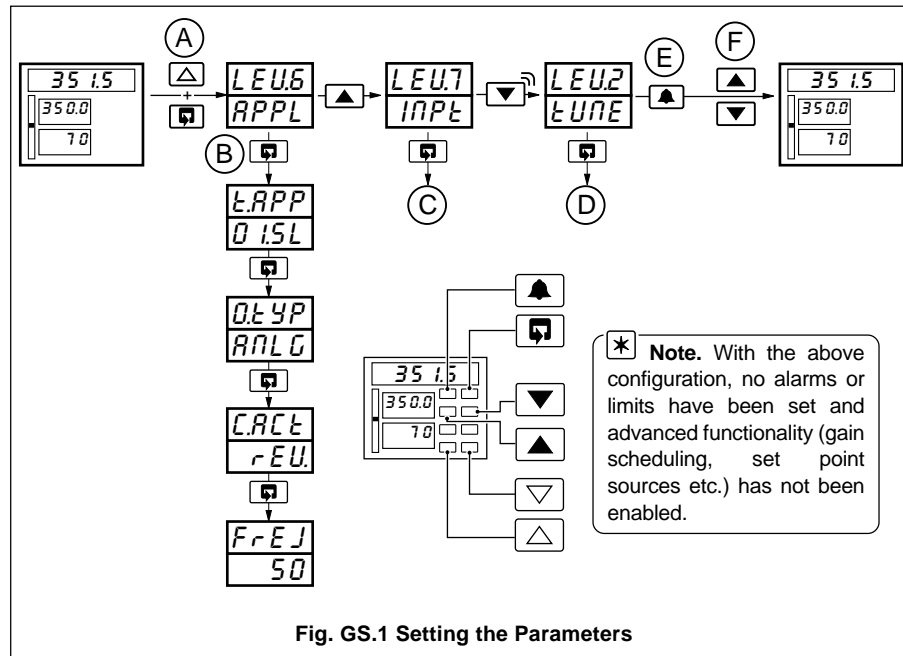

Fig. GS.1 Setting the Parameters

The Company

We are an established world force in the design and manufacture of instrumentation for industrial process control, flow measurement, gas and liquid analysis and environmental applications.

As a part of ABB, a world leader in process automation technology, we offer customers application expertise, service and support worldwide.

We are committed to teamwork, high quality manufacturing, advanced technology and unrivalled service and support.

The quality, accuracy and performance of the Company's products result from over 100 years experience, combined with a continuous program of innovative design and development to incorporate the latest technology.

The NAMAS Calibration Laboratory (No. 0255) is just one of ten flow calibration plants operated by the Company, and is indicative of our dedication to quality and accuracy.

BS EN ISO 9001:2000



Cert. No. Q 05907

EN 29001 (ISO 9001)



Lenno, Italy – Cert. No. 9/90A

Stonehouse, U.K.



Use of Instructions



**Warning.** An instruction that draws attention to the risk of injury or death.



**Note.** Clarification of an instruction or additional information.



**Caution.** An instruction that draws attention to the risk of damage to the product, process or surroundings.



**Information.** Further reference for more detailed information or technical details.

Although **Warning** hazards are related to personal injury, and **Caution** hazards are associated with equipment or property damage, it must be understood that operation of damaged equipment could, under certain operational conditions, result in degraded process system performance leading to personal injury or death. Therefore, comply fully with all **Warning** and **Caution** notices.

Information in this manual is intended only to assist our customers in the efficient operation of our equipment. Use of this manual for any other purpose is specifically prohibited and its contents are not to be reproduced in full or part without prior approval of the Marketing Communications Department.

Health and Safety





To ensure that our products are safe and without risk to health, the following points must be noted:

1. The relevant sections of these instructions must be read carefully before proceeding.
2. Warning labels on containers and packages must be observed.
3. Installation, operation, maintenance and servicing must only be carried out by suitably trained personnel and in accordance with the information given.
4. Normal safety precautions must be taken to avoid the possibility of an accident occurring when operating in conditions of high pressure and/or temperature.
5. Chemicals must be stored away from heat, protected from temperature extremes and powders kept dry. Normal safe handling procedures must be used.
6. When disposing of chemicals ensure that no two chemicals are mixed.

Safety advice concerning the use of the equipment described in this manual or any relevant hazard data sheets (where applicable) may be obtained from the Company address on the back cover, together with servicing and spares information.



# OVERVIEW

This manual is divided into 5 sections which contain all the information needed to install, configure, commission and operate the COMMANDER 351. Each section is identified clearly by a symbol as shown in Fig. 1.

	<b>Displays and Controls</b> <ul style="list-style-type: none"><li>• Displays and Function Keys</li><li>• LED Indication</li><li>• Error Messages</li></ul>		<b>Configuration Mode (Levels 6 to E)</b> <ul style="list-style-type: none"><li>• Level 6 – Basic Configuration</li><li>• Level 7 – Input Configuration</li><li>• Level 8 – Alarm Configuration</li><li>• Level 9 – Set Point Configuration</li><li>• Level A – Control Configuration</li><li>• Level B – Operator Configuration</li><li>• Level C – Output Configuration</li><li>• Level D – Serial Communications</li><li>• Level E – System Calibration</li></ul>
	<b>Operator Mode (Level 1)</b> <ul style="list-style-type: none"><li>• Single Loop Controller</li><li>• Motorized Valve Controller</li><li>• Auto/Manual &amp; Backup Stations</li></ul>		
	<b>Set Up Mode (Levels 2 to 5)</b> <ul style="list-style-type: none"><li>• Level 2 – Tuning</li><li>• Level 3 – Set Points</li><li>• Level 4 – Alarm Trip Points</li><li>• Level 5 – Valve Setup</li></ul>		<b>Installation</b> <ul style="list-style-type: none"><li>• Siting</li><li>• Mounting</li><li>• Electrical Connections</li></ul>

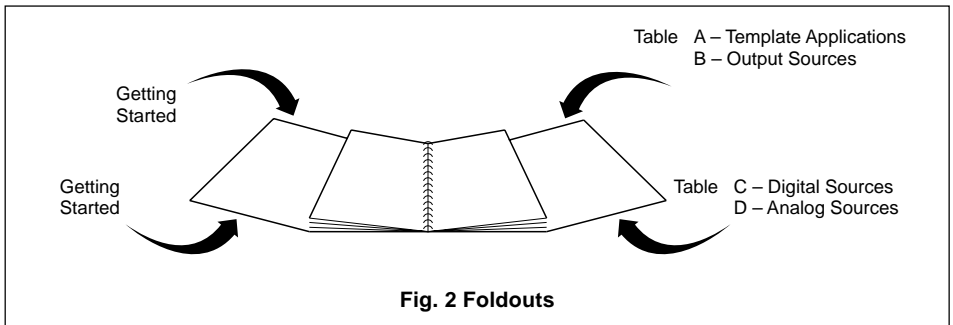
**Fig. 1 Overview of Contents**

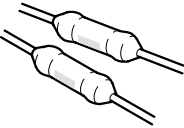
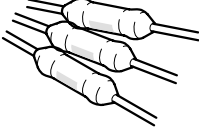
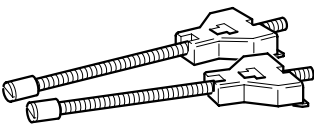

			
<b>Pull-up Resistors</b> 2 x 100k $\Omega$	<b>Shunt Resistors</b> 3 x 100 $\Omega$	<b>Panel Clamps</b> x2	<b>CJ Sensor</b> x2

**Fig. 3 Accessories**

# CONTENTS

Section	Page	Section	Page
<b>1 DISPLAYS AND FUNCTION KEYS .....</b>	<b>3</b>	<b>5 INSTALLATION .....</b>	<b>71</b>
1.1 Introduction .....	3	5.1 Mechanical Installation .....	71
1.2 Use of Function Keys .....	4	5.2 Electrical Installation .....	75
1.3 Secret-til-Lit Indicators .....	8	5.3 Relays .....	78
1.4 Character Set .....	8	5.4 Digital Output .....	78
1.5 Error Messages .....	9	5.5 Control or Retransmission Analog Output .....	78
1.6 Processor Watchdog .....	10	5.6 Motorized Valve Connections .....	79
1.7 Loop Break Monitor .....	10	5.7 Input Connections .....	79
1.8 Glossary of Abbreviations .....	10	5.8 Output Connections .....	80
<b>2 OPERATOR LEVEL .....</b>	<b>11</b>	5.9 Power Supply Connections .....	80
2.1 Introduction .....	11	<b>APPENDIX A – CONTROL TEMPLATES ....</b>	<b>81</b>
2.2 Single Loop Controller (Templates 1 and 2) .....	12	A1 Single Loop Controller (Templates 1 and 2) .....	81
2.3 Auto/Manual Station (Templates 3 and 4) .....	14	A2 Auto/Manual Station and Analog Backup Station .....	82
2.4 Analog Backup (Templates 5 and 6) .....	16	A3 Indicator/Manual Loader Station (Templates 7 and 8) .....	85
2.5 Indicator/Manual Loader Station (Templates 7 and 8) .....	18	<b>APPENDIX B – COMMANDER CONFIGURATION EDITOR .....</b>	<b>86</b>
2.6 Heat/Cool Output Types .....	19	B1 Introduction .....	86
2.7 Motorized Valve Output Types .....	20	B2 Analog Input Customization .....	86
2.8 Auto-tune .....	21	B3 Four Programmable Math Blocks ..	86
2.9 Control Efficiency Monitor .....	24	B4 Six Logic Equations .....	86
<b>3 SET UP MODE .....</b>	<b>27</b>	B5 Process Alarm Customization .....	86
3.1 Introduction .....	27	B6 Two Real Time Alarms .....	86
3.2 Level 2 – Tune .....	28	B7 Two Delay Timers .....	87
3.3 Level 3 – Set Points .....	32	B8 Two Custom Linearizers .....	87
3.4 Level 4 – Alarm Trip Points .....	34	B9 Template Customization .....	87
3.5 Level 5 – Valve Setup .....	35	B10 Connecting the COMMANDER PC Configurator .....	87
<b>4 CONFIGURATION MODE .....</b>	<b>38</b>	<b>SPECIFICATION .....</b>	<b>88</b>
4.1 Introduction .....	38	<b>FRAMES INDEX .....</b>	<b>92</b>
4.2 Level 6 – Basic Configuration .....	39	<b>INDEX .....</b>	<b>95</b>
4.3 Level 7 – Analog Inputs .....	43		
4.4 Level 8 – Alarms .....	47		
4.5 Level 9 – Set Point Configuration ...	51		
4.6 Level A – Control Configuration ....	54		
4.7 Level B – Operator Configuration ..	59		
4.8 Level C – Output Assignment Configuration .....	61		
4.9 Level D – Serial Communications Configuration .....	67		
4.10 Level E – Calibration .....	68		

## 1.1 Introduction

The COMMANDER 351 front panel displays, function keys and l.e.d. indicators are shown in Fig. 1.1.

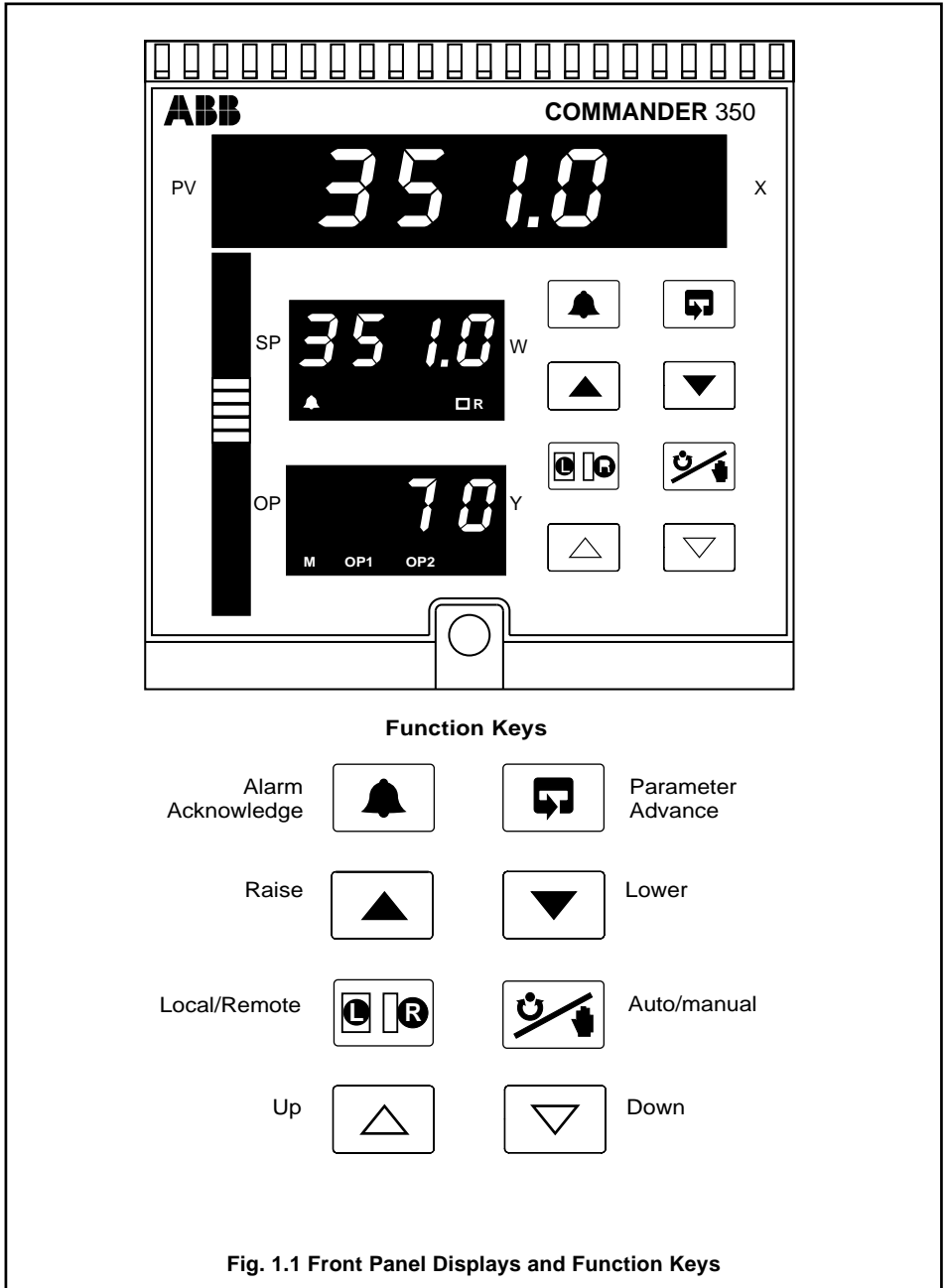
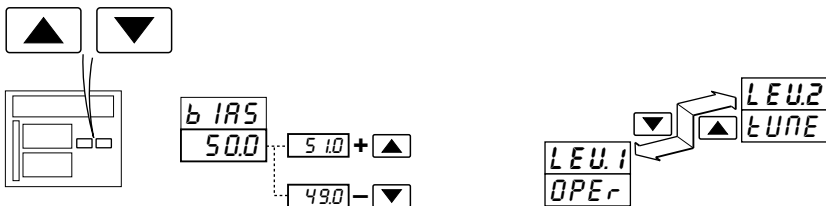

Fig. 1.1 Front Panel Displays and Function Keys

1.2 Use of Function Keys

**A – Raise and Lower Keys**



Use to change/set a parameter value... and... ...move between levels

**B – Up and Down Keys**

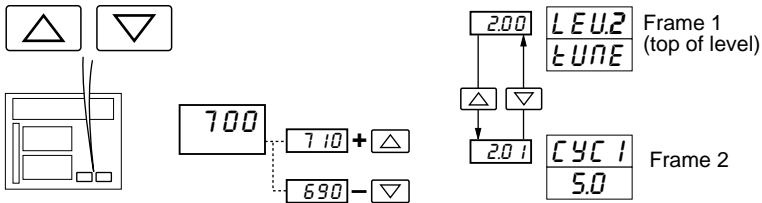

Use to adjust the output value... and... ...move between frames within a Setup or Configuration level. Any changes made in the current frame are stored when the next frame is selected.

**C – Parameter Advance Key**

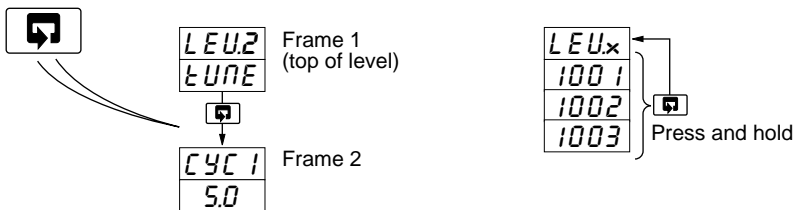

Use to advance to the next frame within a level... or... ...select the top (LEV.x) frame from within a level

**\* Note.** This key also stores any changes made in the previous frame

**D – Auto/Manual Key**

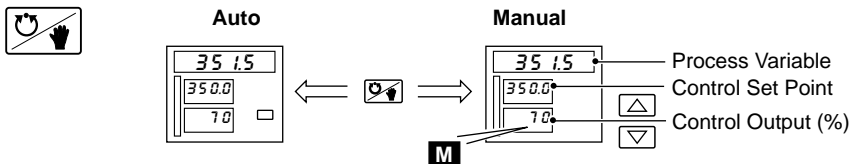

Use to select Auto or Manual control mode

Fig. 1.2a Use of Function Keys

## ...1.2 Use of Function Keys

## E – Alarm Acknowledgement

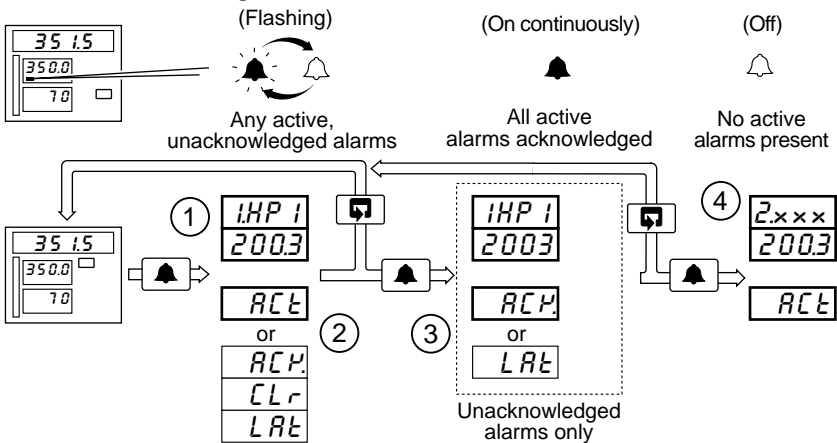

\* **Note.** If no alarms have been enabled in the Set Up level, pressing the key has no effect.

- ① The first active and unacknowledged alarm is displayed (or if no alarms are active, the first enabled alarm is displayed)

HPU	High Process, PV	HO	High Output
LPV	Low Process, PV	LO	Low Output
HLP	High Latch, PV	PFE	Power Failure Time *
LLP	Low Latch, PV	Hb1	Math Block 1 High
Hd	High Deviation	Lb1	Math Block 1 Low
Ld	Low Deviation	Hb2	Math Block 2 High
HP1	High Process I/P1	Lb2	Math Block 2 Low
LP1	Low Process I/P1	Hb3	Math Block 3 High
HP2	High Process I/P2	Lb3	Math Block 3 Low
LP2	Low Process I/P2	Hb4	Math Block 4 High
HP3	High Process I/P3	Lb4	Math Block 4 Low
LP3	Low Process I/P3		

\* **Note.** The time of the power failure, PFE, is shown in the set point display.

- ② The lower display shows alarm status:  
 ACt Alarm active and unacknowledged  
 ACk Alarm active and acknowledged  
 CLr Cleared or Inactive alarm  
 LALt Unacknowledged latched alarm
- ③ Pressing again acknowledges the displayed alarm. Lower display changes to reflect new status.
- ④ Next active and unacknowledged alarm is displayed. If no alarms are active, the next enabled alarm is displayed.

Fig. 1.2b Use of Function Keys

...1.2 Use of Function Keys

F – Local / Remote Key

Changing between Local and Remote Set Points

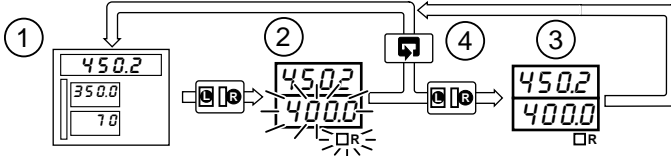

- ① Process variable and local set point displayed on red and green displays.
- ② Remote set point value is displayed. The value and □R symbol flash to indicate local set point still selected.
- ③ Remote set point selected.
- ④ Remote selection aborted.

\* **Note.** When an Analog Backup template is selected, the key is used to switch between local and remote mode – see Sections 2.4 and 4.2.

Selecting Local Set Points 1 to 4

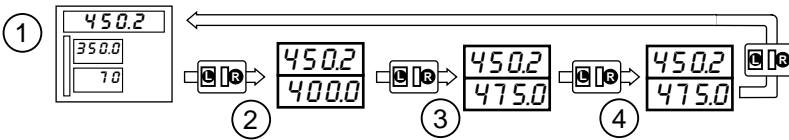

- ① Process variable and local set point 1 displayed.
- ② Process variable and local set point 2 displayed
- ③ Process variable and local set point 3 displayed
- ④ Process variable and local set point 4 displayed

Fig. 1.2c Use of Function Keys



## ...1.2 Use of Function Keys

## G – Short-cut Keys



LEUR  
Cntrl



LEU.1  
OPER

Press to move from anywhere in the Configuration level to the first frame in the Operator level



Press simultaneously and hold for 3 seconds

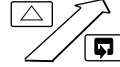

LEU.6  
APPL

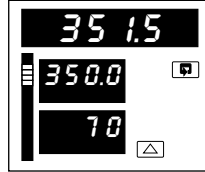

Press to move from anywhere in the Operator or Setup levels to the first page of the Configuration level



**Note.** This Short-cut key combination operates only when the Configuration password is set to '0'.

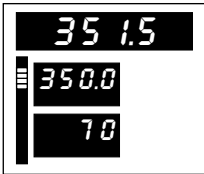

CODE  
0

Press to move from the Operator Level to the Security Code Frame and then to other levels:

Tune Level – See Section 2.13.3

Set Up Level – See Fig. 3.1

Configuration Level – See Fig. 4.1

Fig. 1.2d Use of Function Keys

1.3 Secret-til-Lit Indicators

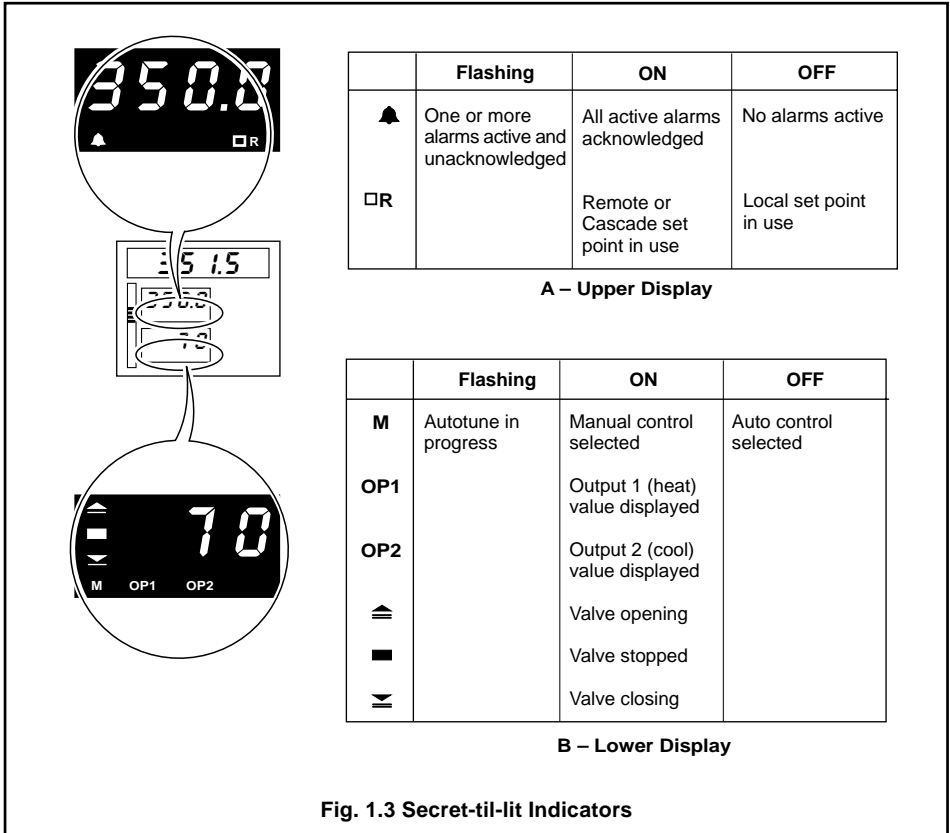
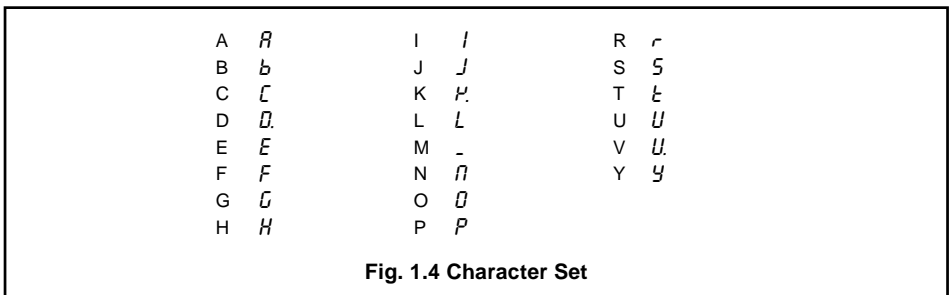
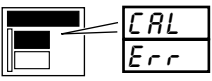

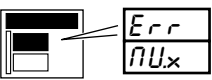

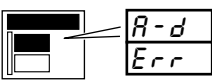
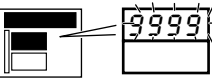
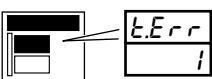

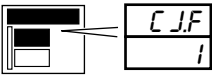
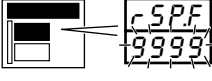
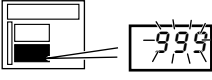
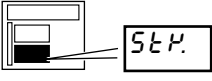

Fig. 1.3 Secret-til-lit Indicators

1.4 Character Set – Fig. 1.4



## 1.5 Error Messages

Display	Error/Action	To clear the display:
	<b>Calibration Error</b> Turn mains power off and on again (if the error persists contact the Customer Support Organization).	Press the  key
	<b>Non-volatile Memory Error</b> x = 1: Processor Board Memory x = 3: Power Supply Board Memory Turn mains power off and on again (if the error persists, check configuration/setup settings).	Press the  key
	<b>A to D Converter Fault</b> The analog to digital converter is not communicating correctly.	Contact the Customer Support Organization
	<b>Input Value Over/Under Range</b>	Restore valid input
	<b>Auto-tune Error</b> Number displayed indicates the type of error – see Table 2.1, page 30.	Press the  key
	<b>Cold Junction Failed</b> Cold junction sensor is faulty or has not been fitted correctly.	Check connections or replace if faulty.
	<b>Remote Set Point Failed</b> Input value is over- or under-range. Only appears if the remote set point is displayed or in use.	Restore valid input
	<b>Position Feedback Fail</b> Input value is over- or under-range. Only appears if output type set to 'Pfb' – motorized valve with feedback.	Restore valid input
	<b>Valve Sticking</b> Motorized valve not moving at the speed expected. Valve may be sticking.	Check that the correct Regulator Travel Time has been set – see Section 3.5. Check the valve.

### 1.6 Processor Watchdog

The instrument's processor activity is monitored by an independent watchdog device. When the output of the watchdog is assigned to a relay or digital output, the relay/digital output de-energizes if the instrument fails to function correctly.

### 1.7 Loop Break Monitor

Analog output 1 is monitored continuously to detect a loop break. A warning signal or other action can be initiated by assigning the loop break signal to relays or digital outputs.

### 1.8 Glossary of Abbreviations

Abbreviation	Description	Abbreviation	Description
PV	Process Variable	I/P1	Analog Input 1
LSPt	Local Set Point Value	I/P2	Analog Input 2
LSP1	Local Set Point 1 Value	I/P3	Analog Input 3
LSP2	Local Set Point 2 Value	di1	Digital Input 1
LSP3	Local Set Point 3 Value	di2	Digital Input 2
LSP4	Local Set Point 4 Value	di3	Digital Input 3
CSPt	Control Set Point Value	di4	Digital Input 4
RSPt	Remote Set Point Value	ao1	Analog Output 1
PID O/P	Output of the PID Algorithm	ao2	Analog Output 2
OP1	Controller Output 1 (heat)	do1	Digital Output 1
OP2	Controller Output 2 (cool)		

**Table 1.1 Glossary of Abbreviations**



### 2.1 Introduction

The Operator level (Level 1) is the normal day-to-day mode of the COMMANDER 351. This section describes the operator facilities available on each frame depending on the control template and output type selected.

The template types detailed in this section are:

- Single loop controller
- Auto/Manual station
- Analog backup station
- Indicator/manual loader station

**\* Note.** Only the frames relevant to the selected template are displayed – see Section 4.

In addition, frames used to view the Control Efficiency Monitor and operate motorized valve and heat/cool output types are also described.

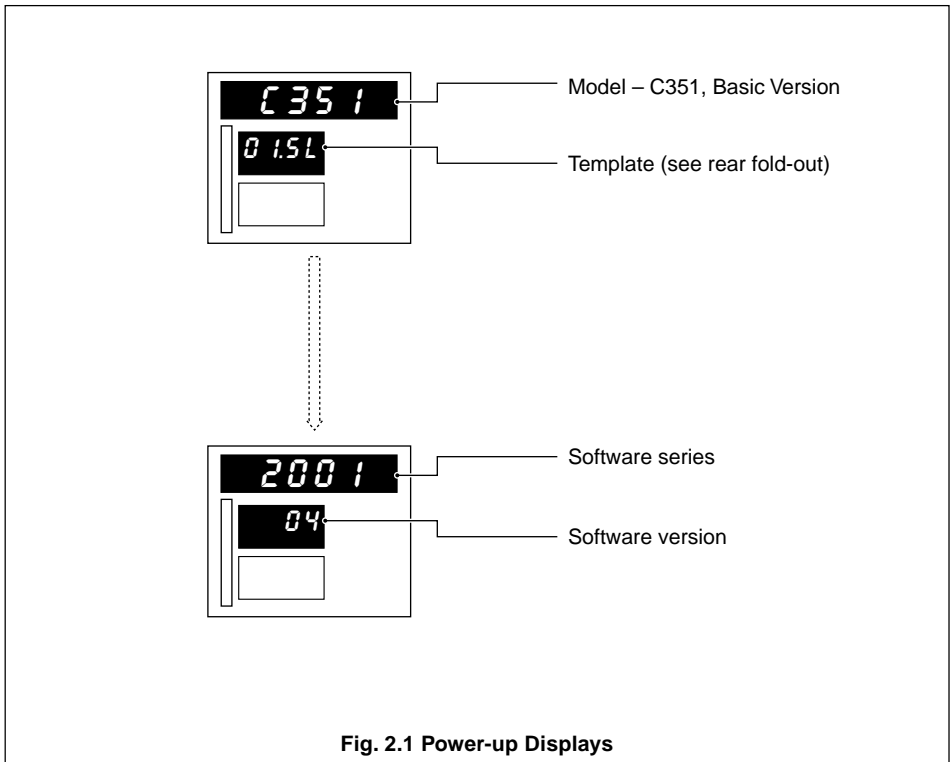

**Fig. 2.1 Power-up Displays**



## 2.2 Single Loop Controller (Templates 1 and 2)

The single loop controller is a basic feedback control system using three-term PID or on/off control with either a local set point (template 1) or remote set point (template 2).

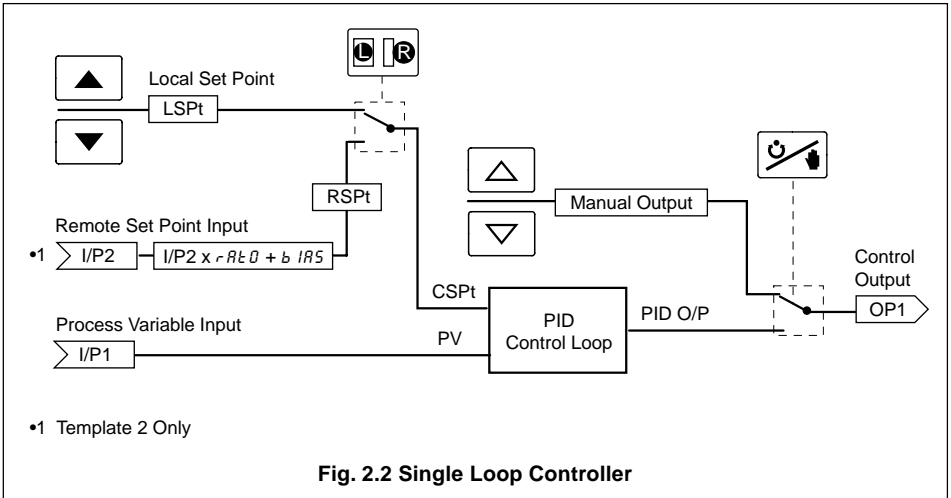
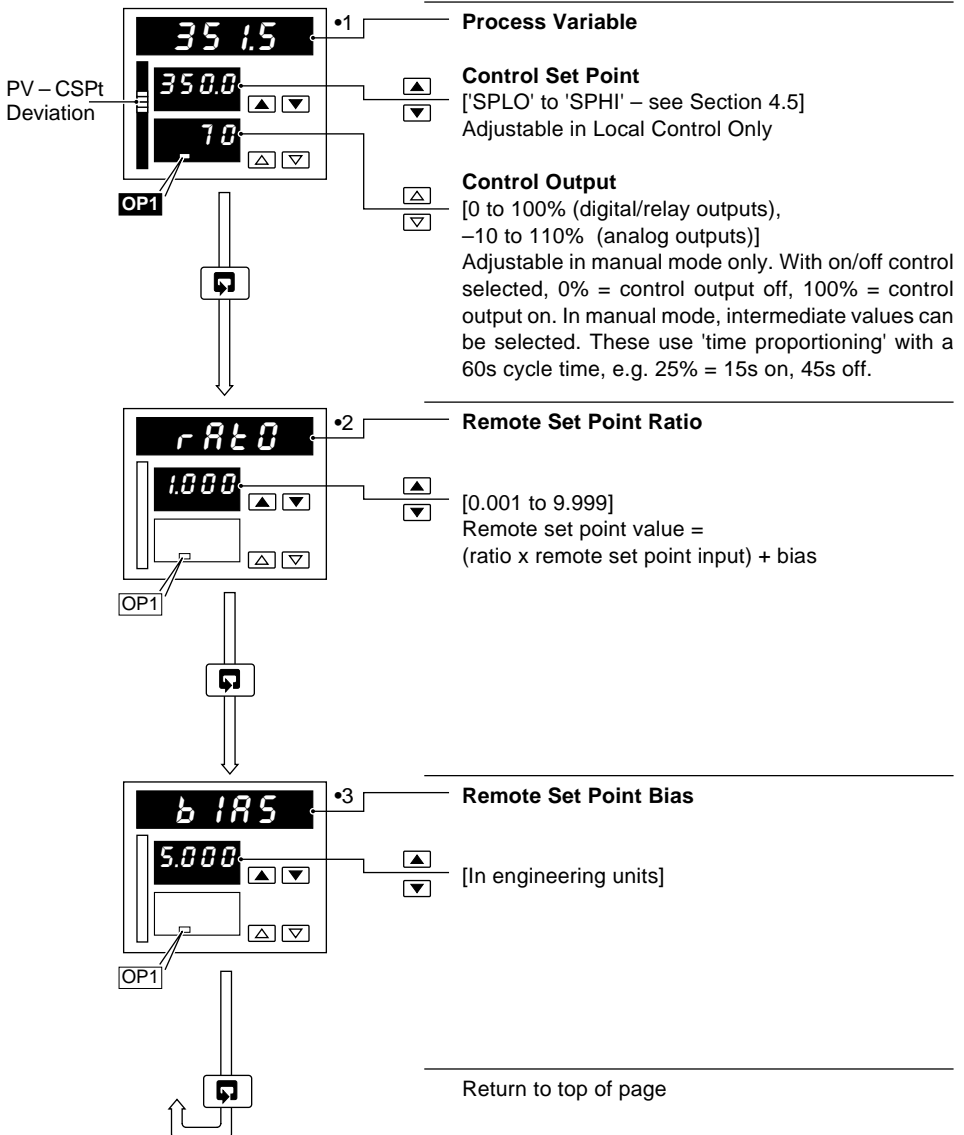

Fig. 2.2 Single Loop Controller



## ...2.2 Single Loop Controller (Templates 1 and 2)



- 1 With the Ramping Set Point function enabled (see Section 3.3, Set Points/ Ramp Rate), the bargraph shows the actual (ramping) set point value and the digital display shows the target set point value.
- 2 Displayed only if template 2 selected and Ratio Display is enabled – see Section 4.2, Basic Configuration and Section 4.7, Operator Configuration.
- 3 Displayed only if template 2 selected and Bias Display is enabled – see Section 4.2, Basic Configuration and Section 4.7, Operator Configuration.



### 2.3 Auto/Manual Station (Templates 3 and 4)

\* **Note.** Refer also to Appendix A2.1 – Series and Parallel Operation.

The auto/manual station provides a backup for a master controller. In normal operation the COMMANDER 350's analog output follows the master controller's output value. A fault in the master system can be identified either by detecting a low signal on the master output (template 3) or via a digital signal (template 4). When a fault is detected the COMMANDER 350 goes into manual mode with its output either set to the last valid master output value or to a configured output value – see Section 4.6, Control Configuration/ Configured Output 1. When the master output is restored or the digital input returns to its inactive state, the COMMANDER 350 switches back to auto mode.

\* **Note.** The Alarm A1 Trip value must be set when using template 3.

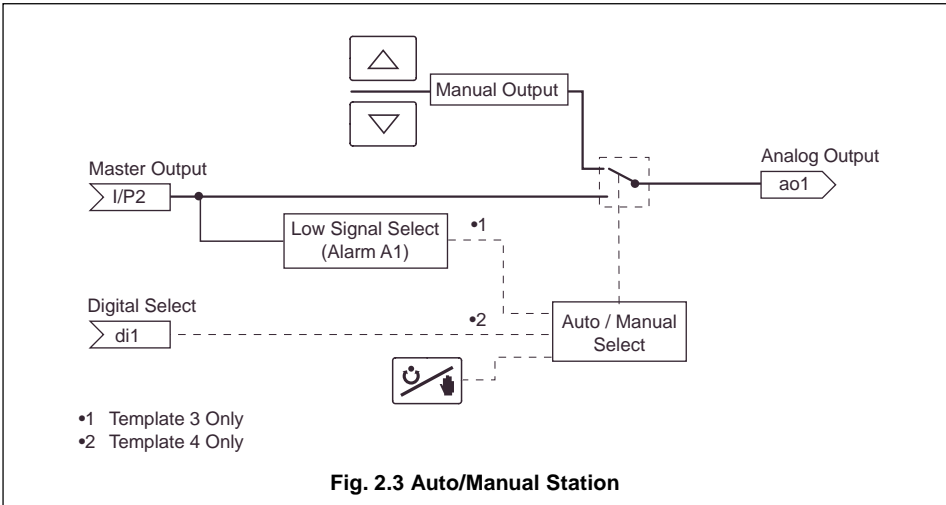





### ...2.3 Auto/Manual Station (Templates 3 and 4)

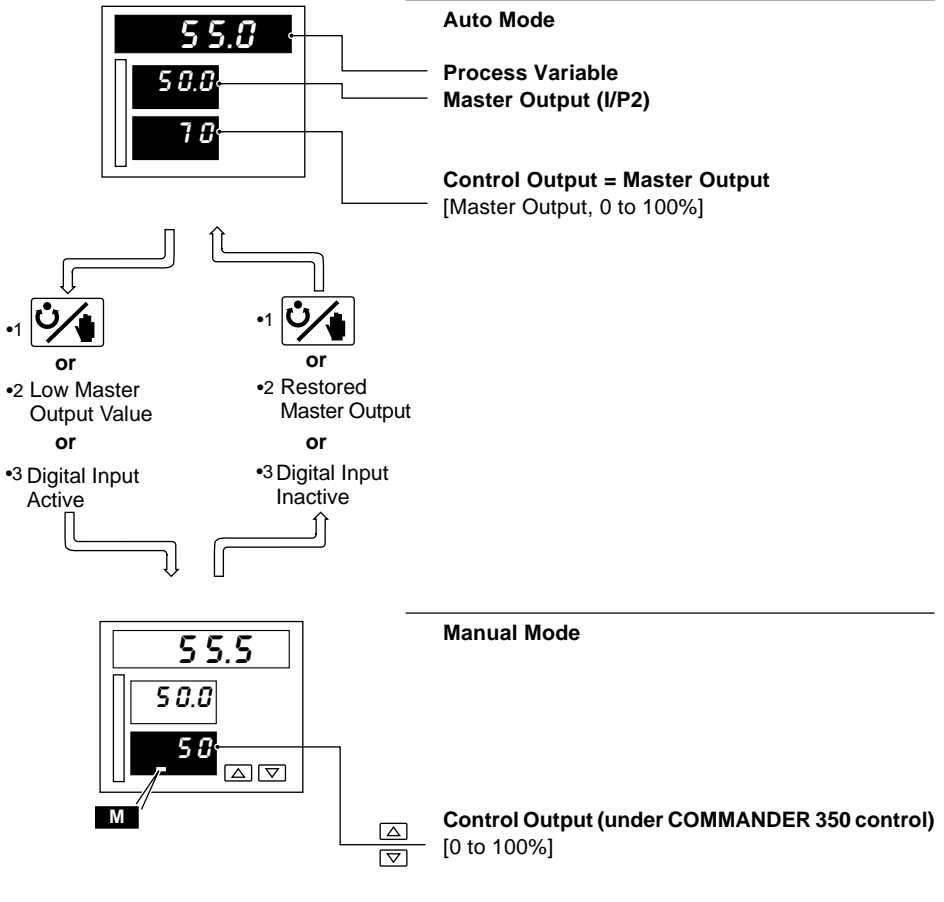

- 1 In template 4 the Auto/Manual key is overridden by the digital input signal.
- 2 Template 3 only – see Section 4.2, Basic Configuration/ Template Application.
- 3 Template 4 only – see Section 4.2, Basic Configuration/ Template Application.



### 2.4 Analog Backup (Templates 5 and 6)

**Note.** Refer also to Appendix A2.1 – Series and Parallel Operation.

The analog backup station provides a backup for a master controller. In normal operation (remote control mode selected) the COMMANDER 350's current output follows the master controller's output value. A fault in the master system can be identified either by detecting a low signal on the master output (template 5) or via a digital signal (template 6). When a fault is detected the COMMANDER 350 switches into local control mode and the process is controlled by the PID output of the COMMANDER 350. The COMMANDER 350 PID algorithm tracks the master output value continuously, in order to ensure bumpless transfer from remote to local mode operation. When the master output is restored or the digital input returns to its inactive state, the COMMANDER 350 switches back to remote control mode.

**Note.** The Alarm A1 Trip value must be set when using template 5.

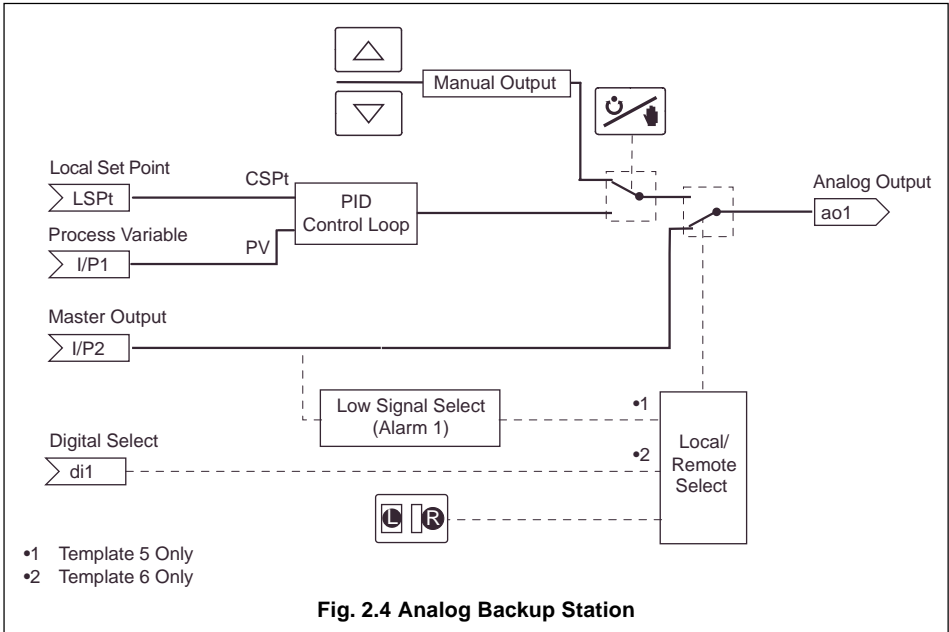



## ...2.4 Analog Backup (Templates 5 and 6)

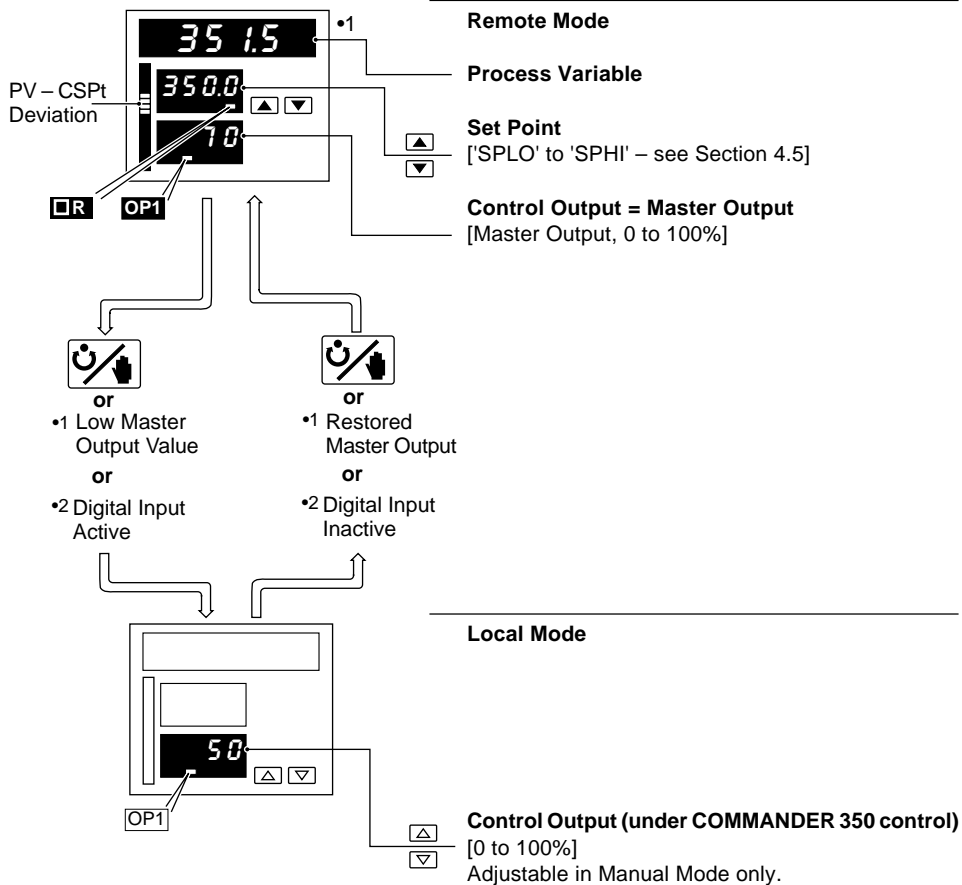

- 1 Template 5 only – see Section 4.2, Basic Configuration/ Template Application.
- 2 Template 6 only – see Section 4.2, Basic Configuration/ Template Application.



### 2.5 Indicator/Manual Loader Station (Templates 7 and 8)

One or two process variables can be displayed on the digital and bargraph displays. If the control output is assigned to an analog output, the lower display indicates its value which can be adjusted by the user.

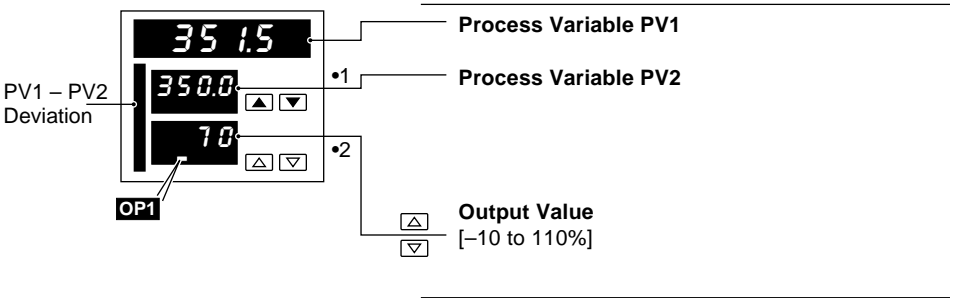

- 1 Displayed only if template 8 selected – see Section 4.2, Basic Configuration/ Template Application.
- 2 Displayed only if control output type is 'analog' (output is assigned to Analog Output 1).



## 2.6 Heat/Cool Output Types

### 2.6.1 Reverse (Heat)/Direct (Cool) or Direct (Heat)/Reverse (Cool)

The active output, either OP1 (Heat) or OP2 (Cool) is displayed and may be adjusted in manual mode. The OP1 and OP2 I.e.d.s indicate which output is changing.

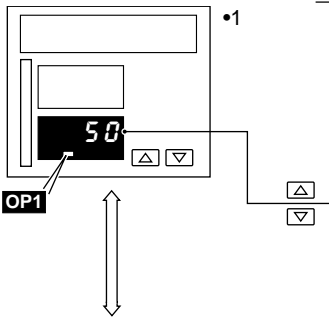
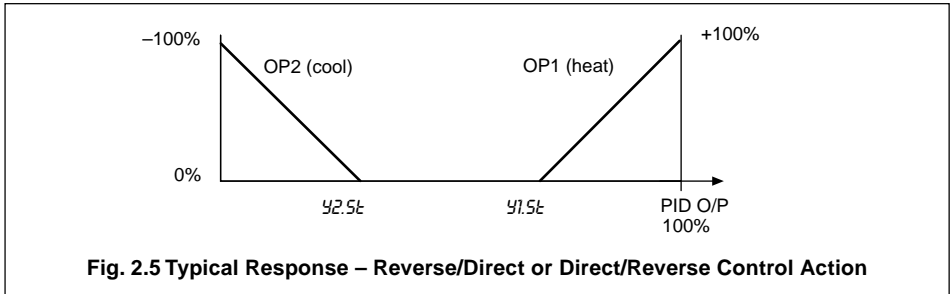

#### Output Positive (Heat Output Active)

##### Heat Output

[0 to 100% (0 to 110% in manual mode with analog outputs)]. Adjustable in manual mode only.

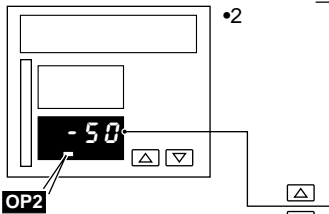

#### Output Negative (Cool Output Active)

##### Cool Output

[-100 to 0% (-110 to 0% in manual mode with analog outputs)]. Adjustable in manual mode only.



### 2.6.2 Reverse (Heat)/Reverse (Cool) or Direct (Heat)/Direct (Cool)

It is not possible to view or adjust the heat/cool outputs directly. The PID output (0 to 100%), used to calculate the heat (OP1) and cool (OP2) outputs, is displayed and may be adjusted in manual mode. The OP1 and OP2 I.e.d.s indicate which output is changing.

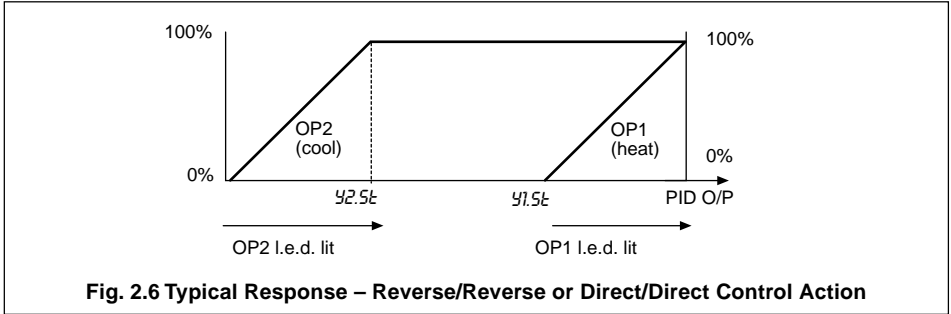

## 2.7 Motorized Valve Output Types

### 2.7.1 Motorized Valve with Feedback

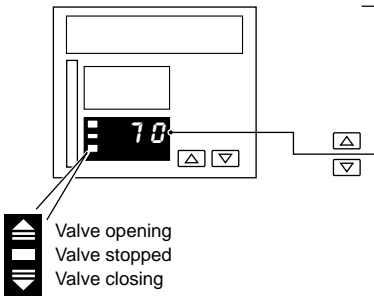

#### Valve Position Display

[0 to 100% of travel]

\* **Note.** In manual mode, the and keys can be used to drive the valve open and valve close relays directly.

### 2.7.2 Motorized Valve without Feedback (Boundless)

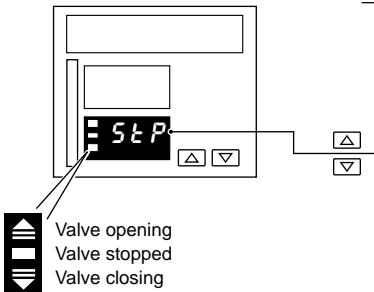

#### Valve State Display

<i>OPn</i>	Valve opening
<i>S t P</i>	Valve stopped
<i>CL S</i>	Valve closing

\* **Note.** In manual mode, the and keys can be used to drive the valve open and valve close relays directly.



## 2.8 Auto-tune

**\* Note.** Auto-tune is not available for Auto/Manual Station or Indicator templates, or when boundless or heat/cool control types are selected.

### **i Information.**

- Auto-tune optimizes process control by manipulating the COMMANDER 350 output and then monitoring the process response.
- At the end of an auto-tune, the control parameters are updated automatically.
- Before starting auto-tune, the process variable must be stable.
- The COMMANDER 350 monitors the noise level of the process variable for 30 seconds and if it is greater than 2% of the engineering range the auto-tune is aborted.
- The COMMANDER 350 selects either 'start-up' or 'at set point' tuning automatically, depending upon the level of the process variable relative to the control set point.

### 2.8.1 Start-up Auto-tune

If the process variable is more than  $\pm 10\%$  from the set point, 'start-up' tuning is carried out.

- 'Start-up' tuning – steps the output to drive the process towards the set point. The process response to this step change is monitored and PID parameters are calculated.
- The output step applied = % deviation from the set point  $\times 1.5$ .
- If no errors exist, the COMMANDER 350 enters auto mode and begins to control the process using the new PID parameters.
- If an error occurs during the auto-tune, the COMMANDER 350 reverts to manual mode with the control output set to the default output value. An error message is displayed in the operator level – see Table 2.1.

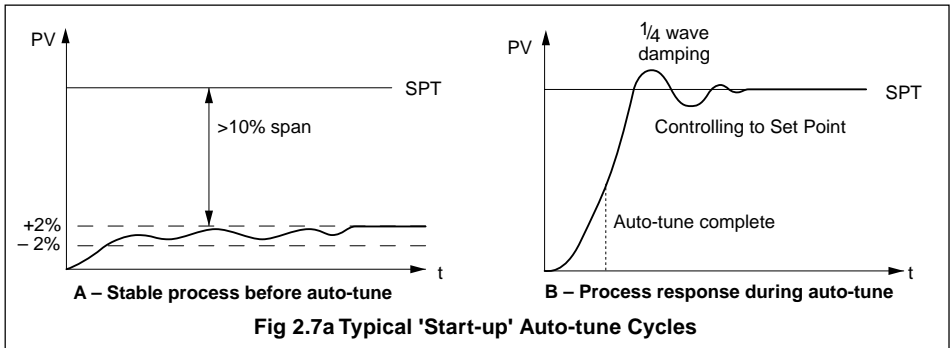

Error	Description	Error	Description
1	PV failed during auto-tune	7	A resultant P, I or D value was calculated out of range
2	Auto-tune has timed out during an auto-tune step	8	PV limit exceeded ('Start up' auto-tune)
3	Process too noisy to auto-tune	9	Controller put into configuration mode
4	Process too fast to auto-tune	10	Auto-tune terminated by user
5	Process too slow to auto-tune (max 12 hours between half-cycles).	11	PV is changing in the wrong direction during step test
6	PV deviated from set point by >25% eng. span during frequency response test		

**Table 2.1 Auto-tune Error Codes**



### 2.8.2 'At Set Point' Auto-tune

If the process variable is within 10% of the set point, 'at set point' tuning is carried out.

- 'At set point' tuning – manipulates the control output to produce a controlled oscillation of the process.
- A step change of  $\pm 10\%$  of the starting output value is applied initially. This is adjusted to give an amplitude of oscillation 3 times the noise level.
- Once the amplitude and period of oscillation are consistent (minimum 2 cycles, maximum 4 cycles) PID parameters are calculated.
- If no errors exist the controller enters auto mode and begins to control the process using the new PID parameters.
- If an error occurs during the auto-tune, the controller reverts to manual mode with the control output set to the default output value. An error message is displayed in the operator level – see Table 2.1.

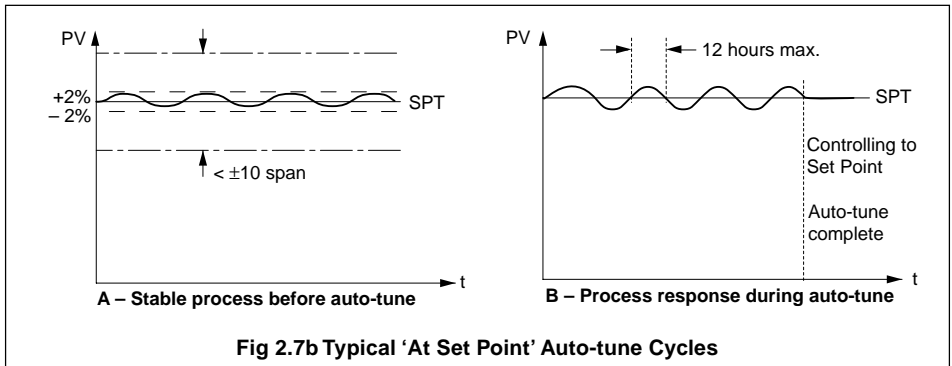

\* **Note 1.** The time taken to complete auto-tune depends upon the system response time.

\* **Note 2. Time Proportioning** – the cycle time must be set prior to running an auto-tune. The cycle time is not changed by the auto-tune.





### 2.8.3 Auto-tune

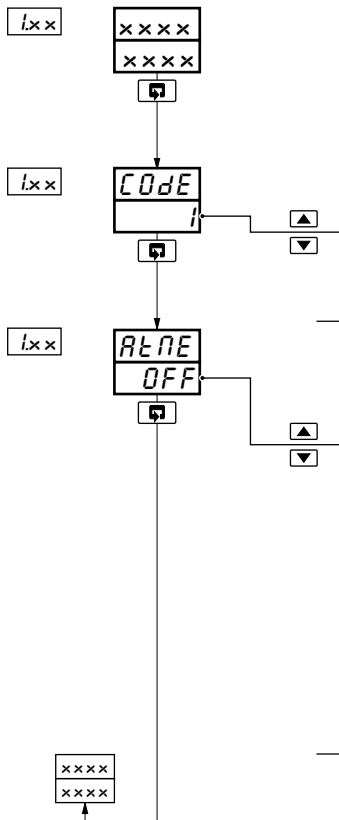

#### Accessing the Auto-tune Facility

From any operating frame, press and hold the key until the 'CODE' frame is displayed.

Set the correct auto-tune password.

#### Auto-tune Enable

Select the type of auto-tune required.

#### Single Loop Templates

- OFF - Off
- A - Type A
- B - Type B

Auto-tune is started automatically when the key is pressed.

Auto-tune can be stopped at any time by pressing the key.

**Note. P + I control only** – set the derivative term to 'OFF' in the Tuning Level – see Section 3.2.

Return to the Operating Level.

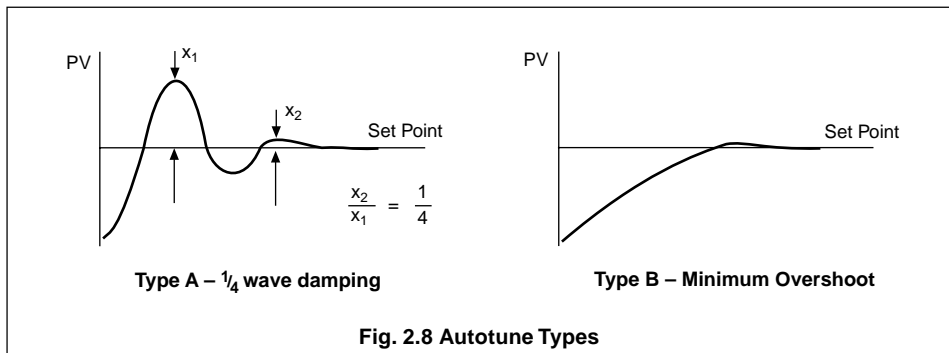



## 2.9 Control Efficiency Monitor

The Control Efficiency Monitor can be used either to compare the relative performance with different tuning parameters, or when fine tuning the PID settings, to give optimum control.

When the set point is changed, auto mode is selected or following a power failure, input failure or a large load disturbance, the control monitor performs a series of measurements to indicate the effectiveness of the current control parameters.

General guidelines are shown in Table 2.2.



Parameter	Ideal Setting	Actual Setting	Effect on Response	Action
Rate of Approach	Fast	Too slow		<ul style="list-style-type: none"> <li>Decrease proportional band</li> <li>Decrease integral time</li> <li>Increase derivative time</li> </ul>
Overshoot	Small	Too large		<ul style="list-style-type: none"> <li>Increase proportional band</li> <li>Increase derivative time</li> </ul>
Decay Ratio	Small	Too large (Oscillatory)		<ul style="list-style-type: none"> <li>Increase proportional band</li> <li>Increase integral time</li> </ul>
Settling Time	Short	Too long		<ul style="list-style-type: none"> <li>Increase proportional band</li> <li>Decrease integral time</li> </ul>
Error Integral	Small	Too large	 	<p>If large overshoot and oscillatory then:</p> <ul style="list-style-type: none"> <li>Increase proportional band</li> <li>Increase integral time</li> <li>Increase derivative time</li> </ul> <p>If slow approach and overdamped then:</p> <ul style="list-style-type: none"> <li>Decrease proportional band</li> <li>Decrease integral time</li> </ul>

Table 2.2 Control Efficiency Monitor Settings



## ...2.9 Control Efficiency Monitor

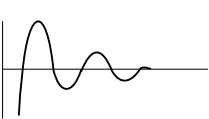
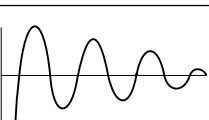
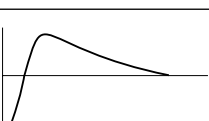
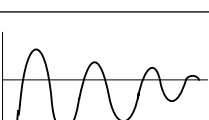

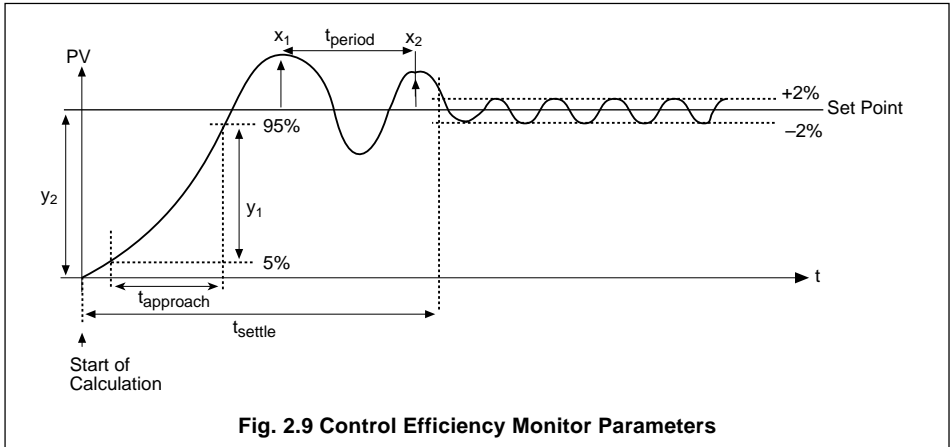
### 2.9.1 Manual Tuning

The Control Efficiency Monitor may be used for manually tuning the PID parameters. The following method describes how to tune the controller for  $1/4$  wave damping:

- a) Set the integral and derivative action times to OFF.
- b) Set the proportional band (PB) to a low setting.
- c) Apply a small set point change.
- d) Use the Control Efficiency Monitor to note the decay ratio.
- e) If the decay ratio  $> 0.25$ , increase the Proportional Band until decay ratio = 0.25  
If the decay ratio  $< 0.25$ , decrease the Proportional Band until decay ratio = 0.25
- f) Leave the proportional band at the setting which gives 0.25 decay ratio and, using the Control Efficiency Monitor, note the period between peaks.
- g) Calculate and set the following parameters:  
Integral action time = Period/1.5  
Derivative action time = Period/6



**Note.** The manual tuning facility must not be used with boundless motorized valve control, as an Integral Action Time is required for these applications.



### 2.9.2 Using the Control Efficiency Monitor

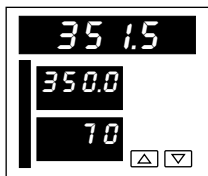

Press and hold the  $\Delta$  and  $\nabla$  keys for 2 seconds.

**\* Note.**

If the front panel keys are not operated for 60 seconds whilst any Control Efficiency Monitor frame is being displayed, the instrument reverts to the first operating frame.

#### Rate of Approach to Set Point

The rate of change of the process variable between 5 and 95% of the step change ( $Y_2$ ), measured in engineering units per minute.

$$\text{Rate of approach} = \frac{Y_1}{t_{\text{approach}}}$$

#### Overshoot

The maximum error, expressed as a percentage of the set point.

$$\text{Overshoot} = \frac{X_1}{\text{Set Point}} \times 100$$

#### Decay Ratio

The ratio of the amplitude of the first and second overshoots.

$$\text{Ratio} = \frac{X_2}{X_1}$$

#### Period

The time (in seconds) between the first two peaks ( $t_{\text{period}}$ ).

#### Settling Time

The time taken (in minutes) for the process variable to settle within  $\pm 2\%$  of the set point value ( $t_{\text{settle}}$ ).

#### Error Integral

The integral of the error value until the process variable settles to within  $\pm 2\%$  of the set point value in 'engineering-unit hours'.

$$\text{Error integral} = \int_0^{t_{\text{settle}}} |PV - SP| dt$$

Return to the first operating frame.

### 3.1 Introduction

To access the Set Up mode (Levels 2 to 5) the correct password must be entered in the security code frame.

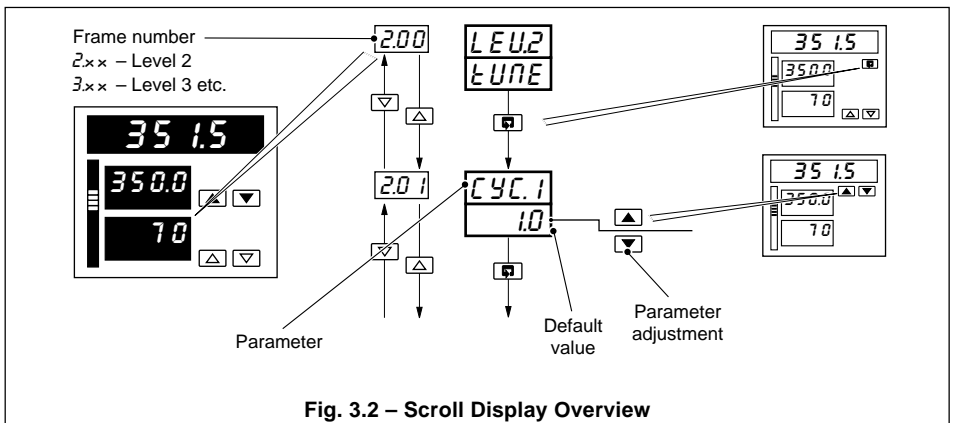
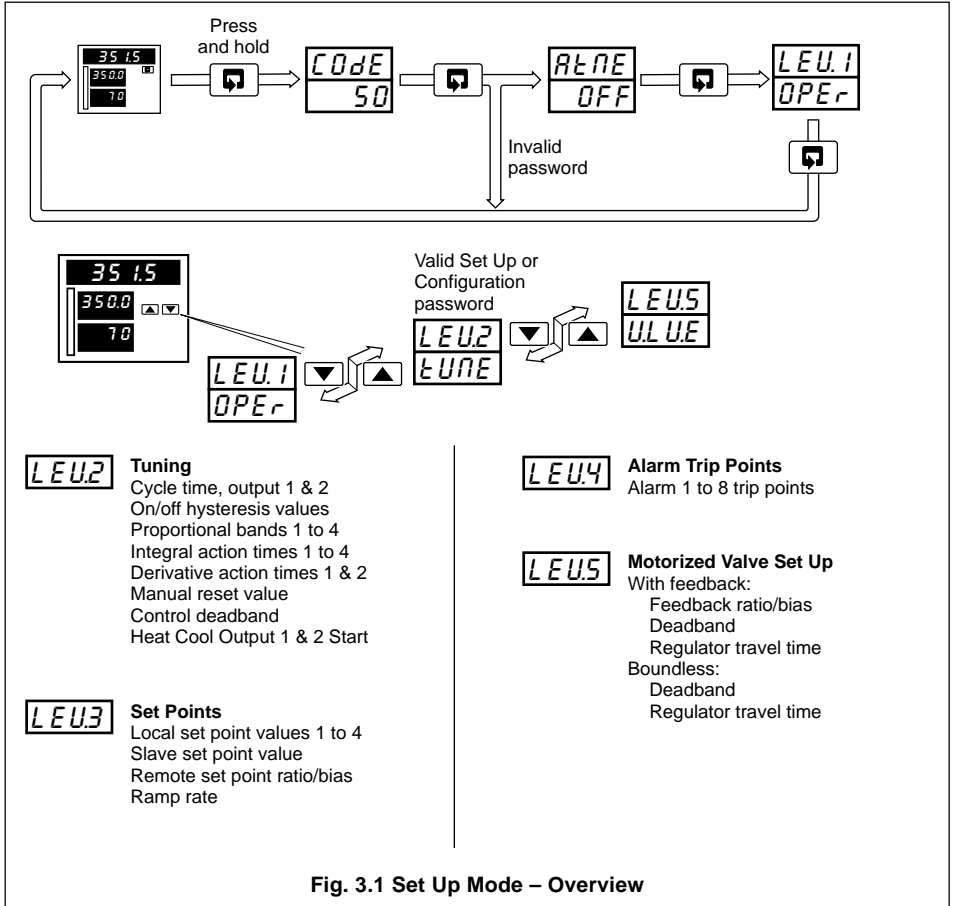



### 3.2 Level 2 – Tune

2.00...2.04

**\* Note.** Level 2 is not applicable if an Auto/Manual Station or Indicator template is selected.

2.00

LEU2  
 TUNE

[Enter]

2.01

CYC1 \*1  
 1.0

[Enter]

2.02

CYC2 \*1  
 \*2  
 1.0

[Enter]

2.03

HYS1 \*3  
 0

[Enter]

2.04

HYS2 \*4  
 0

[Enter]

#### Level 2 – Tune

**\* Note.** To select this frame from anywhere in this page, press and hold the [Enter] key for a few seconds.

#### Cycle Time Output 1

[1.0 to 300.0 seconds for time proportioning or 'ONOFF' for on/off control]

#### Cycle Time Output 2 (Cool)

[1.0 to 300.0 seconds for time proportioning or 'ONOFF' for on/off control]

#### Output 1 On/Off Hysteresis Value

[In engineering units]

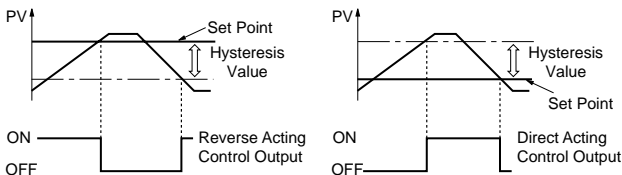

#### Output 2 On/Off Hysteresis Value

[0% to (Y1.St – Y2.St)%] – see parameters 2.22 and 2.23

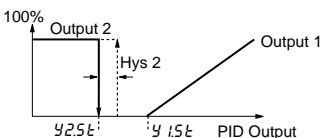

Continued on next page

- 1 Displayed only if Relay or Digital output type is selected – see Section 4.2, Basic Configuration/ Output Type.
- 2 Displayed only if Heat/Cool output type is selected.
- 3 Only if On/Off control is selected – see parameters 2.01 and 2.02 above.
- 4 Displayed only if Heat/Cool output type is select and the 'CYC2' parameter is set to 'ONOFF'.

## ...3.2 Level 2 – Tune

2.05...2.13

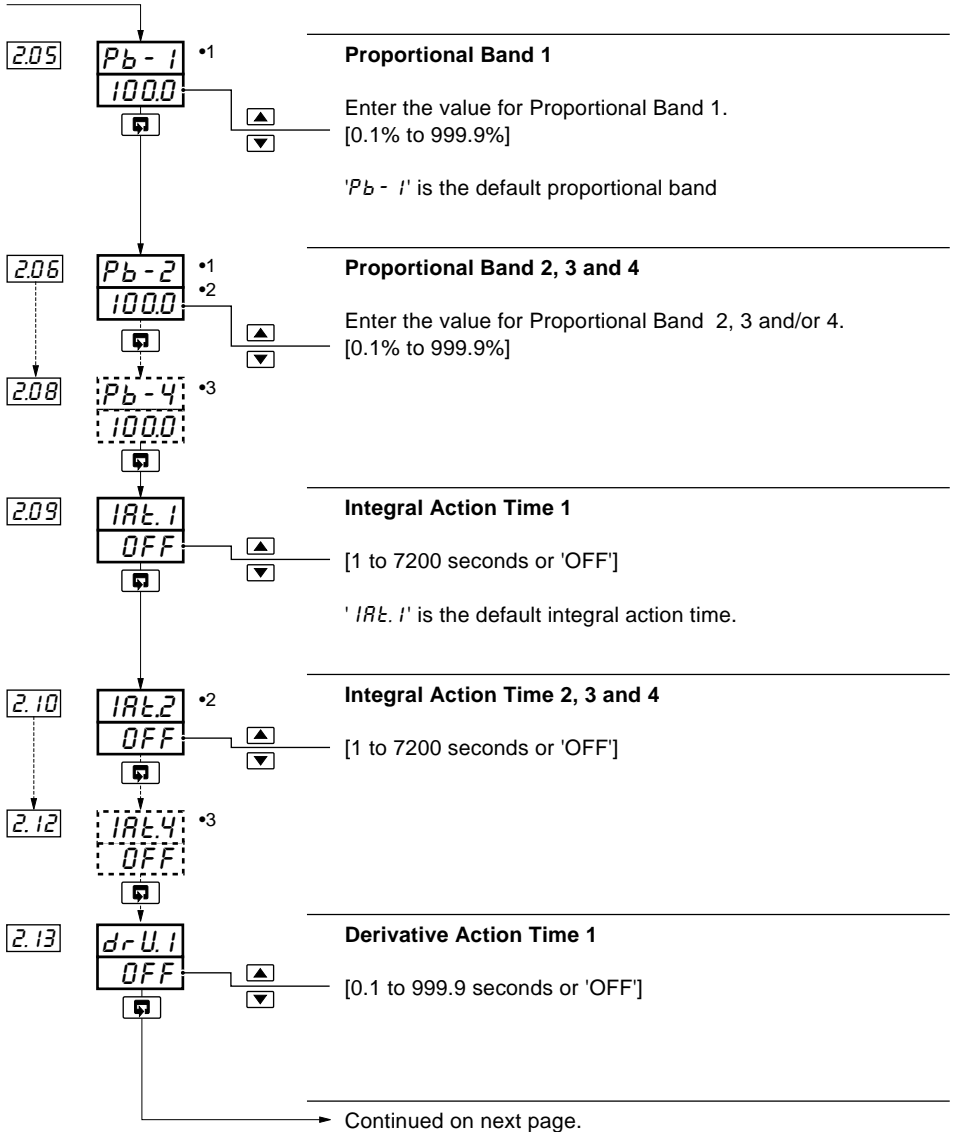

- 1 Heat/cool outputs use a common proportional band. The default is 'Pb - 1'.
- 2 Displayed only if a tune parameter source is selected – see Section 4.2, Basic Configuration/ Template Application and Section 4.6, Control Configuration/ Tune Parameter Source.
- 3 Displayed only if a tune parameter source is selected – see Section 4.6, Control Configuration/ Tune Parameter Source.



...3.2 Level 2 – Tune

2.13...2.21

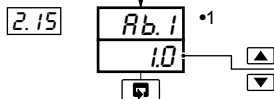

**Approach Band 1**

[0.1 to 3.0 proportional bands]

This parameter limits when derivative action time 1 is applied. When the process variable is outside the approach band, derivative action is not applied.

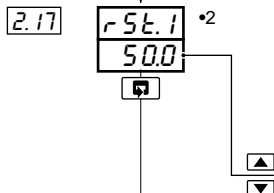

**Manual Reset Value 1**

The value applied to bring the master control output to the zero error point under normal load conditions (integral action disabled) or the offset applied to the control output (integral action enabled).

[0.0 to 100%]

**Note.** Manual reset is applied whether or not an integral action time is set.

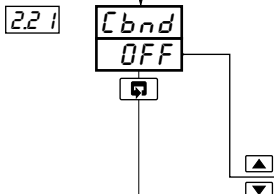

**Control Deadband**

When the process variable is in the deadband, changes to the control output due to proportional and integral action are suppressed. When a cascade template is selected, the control deadband is applied to the master output only.

[In engineering units or 'OFF']

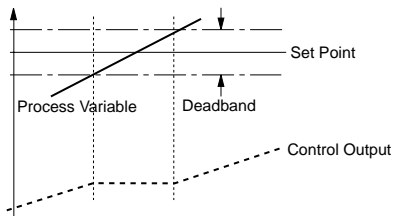

Continued on next page.

- 1 Not displayed if the associated derivative action time is set to OFF.
- 2 If manual control is selected and no integral action time is set, the manual reset value is calculated automatically to give bumpless transfer into auto control.





...3.2 Level 2 – Tune

2.22...2.23

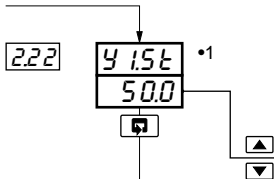

**Heat/Cool Output 1 Start**

This parameter defines the PID output value above which Output 1 (heat) becomes active.

[0.0 to 100.0%]

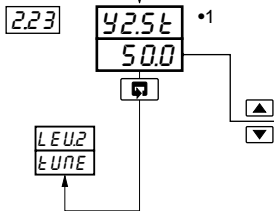
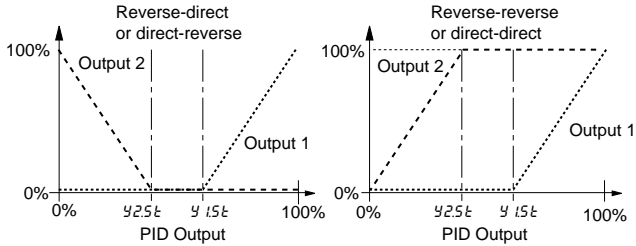

**Heat/Cool Output 2 Start**

This parameter defines the PID output value below which Output 2 (cool) becomes active.

[0.0 to ≤ Y1st %] – see Heat/Cool Output 1

Return to top of page

•1 Displayed only if a Heat/Cool output type is selected – see Section 4.2, Basic Configuration/ Output Type.



### 3.3 Level 3 – Set Points

3.00...3.07

**\* Note.** Level 3 is not applicable if Auto/Manual Station or Indicator templates are selected.

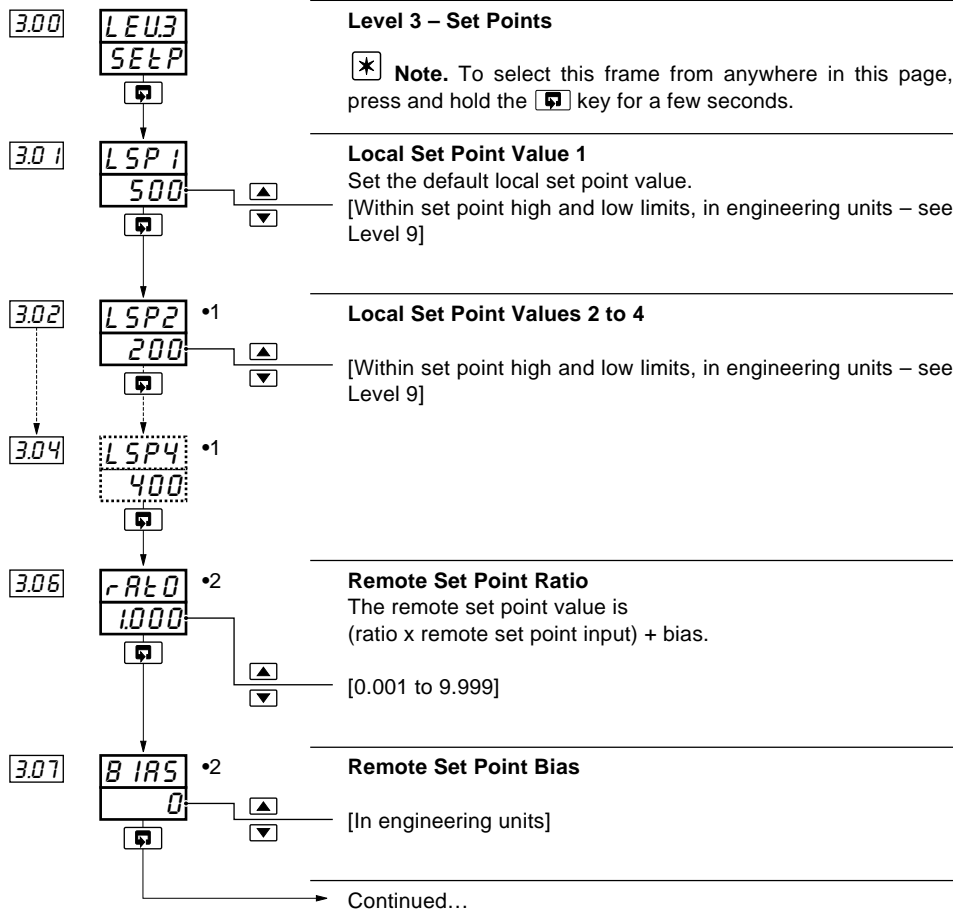

•1 Displayed only if a local set point source is selected – see Section 4.5/ Set Point Configuration/ Local/Remote Set Point Source.

•2 Displayed only for templates with a remote set point.

## ...3.3 Level 3 – Set Points

310

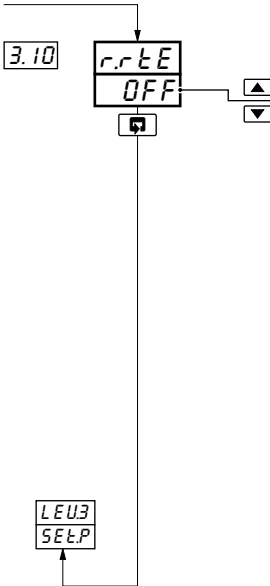
**Ramp Rate**

[1 to 9999 engineering units per hour, or OFF]

The Ramping Set Point facility can be used to prevent a large disturbance to the control output when the set point value is changed. The rate set applies to both the local and the remote set points.

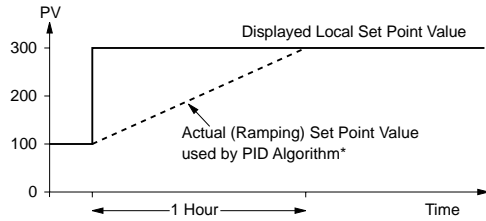

\* e.g. Ramp Rate = 200 Increments/Hour

Return to top of page.



### 3.4 Level 4 – Alarm Trip Points

4.00...4.08

\* **Note.** Level 4 is not applicable if all alarm types are set to 'None' – see Section 4.4, Alarms/ Alarm Type.

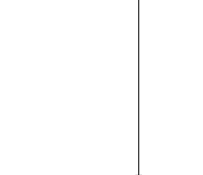
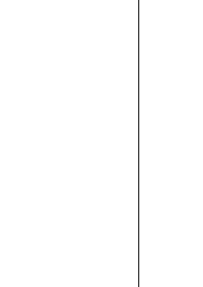
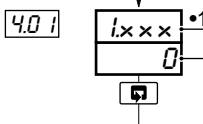
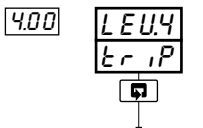

#### Level 4 – Alarm Trip Points

\* **Note.** To select this frame from anywhere in this page, press and hold the key for a few seconds.

#### Alarm 1 Trip

##### Alarm Number and Type

Display	Description	Display	Description
<i>none</i>	None	<i>LP3</i>	Low Process I/P3
<i>HPU</i>	High Process, PV	<i>HO</i>	High Output <span style="float:right">*2</span>
<i>LPU</i>	Low Process, PV	<i>LO</i>	Low Output <span style="float:right">*2</span>
<i>HLP</i>	High Latch, PV	<i>Hb 1</i>	Math Block 1 High
<i>LLP</i>	Low Latch, PV	<i>Lb 1</i>	Math Block 1 Low
<i>Hd</i>	High Deviation	<i>Hb 2</i>	Math Block 2 High
<i>Ld</i>	Low Deviation	<i>Lb 2</i>	Math Block 2 Low
<i>HP 1</i>	High Process I/P1	<i>Hb 3</i>	Math Block 3 High
<i>LP 1</i>	Low Process I/P1	<i>Lb 3</i>	Math Block 3 Low
<i>HP 2</i>	High Process I/P2	<i>Hb 4</i>	Math Block 4 High
<i>LP 2</i>	Low Process I/P2	<i>Lb 4</i>	Math Block 4 Low
<i>HP 3</i>	High Process I/P3		

#### Trip Value

[In engineering units]

\* **Note.** When an auto/manual station template or analog backup template is selected, Alarm 1 is set automatically as a low process alarm on Analog Input 2.

#### Alarm 2 to Alarm 8 Trip

##### Alarm Number and Type

See Alarm 1.

#### Trip Value

[In engineering units]

Return to top of page.

- 1 Not displayed if alarm type set to 'None' – see Section 4.4, Alarms/ Alarm Type.
- 2 Applies to PID output with single or heat/cool outputs.



### 3.5 Level 5 – Valve Setup

5.00...5.04

**\* Note.** Level 5 is applicable only for a motorized valve output type – see Section 4.2, Basic Configuration/ Output Type.

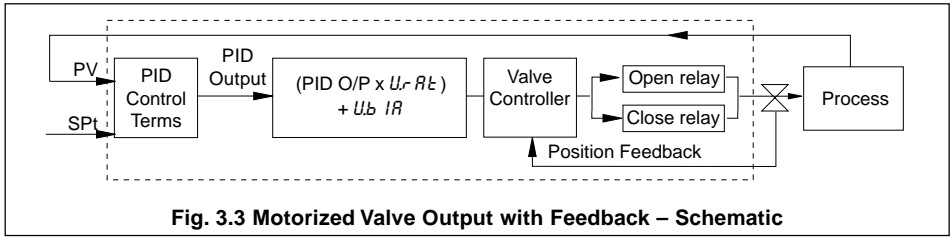

Fig. 3.3 Motorized Valve Output with Feedback – Schematic

#### 3.5.1 Valve Setup (Feedback Types)

5.00

LEUS  
ULUE



#### Level 5 – Valve Setup

**\* Note.** To select this frame from anywhere in this page, press and hold the key for a few seconds.

5.01

U\_r R\_t  
0



#### Motorized Valve Ratio and Bias

Desired valve position = (Ratio x PID output) + Bias

#### Motorized Valve Ratio

[0.01 to 10.00]

5.02

U\_b I\_A  
0



#### Motorized Valve Bias

[-100.0 to 100.0%]

5.03

dbnd  
0



#### Motorized Valve Deadband

[0.0 to 100% of the position feedback span]

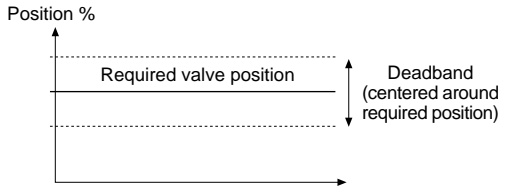

**Example.** If the valve is set to be driven to the 50% open position and the deadband is set to 4%, the motor stops driving when the position feedback is 48%. The deadband is between 48% and 52%.

5.04

r\_t r U  
30



#### Regulator Travel Time

The time entered is compared with the actual travel time. If the valve is sticking an error message is generated.

[0 to 5000 seconds, 0 = no check]

LEUS  
ULUE

Return to top of page.



### 3.5.2 Valve Setup (Boundless Types) – Fig. 3.4

A 'boundless' process controller provides an output that is effectively the time derivative of the required regulator position, i.e. the COMMANDER 350 signals the regulator, not where to go to (position derivative), but in which direction to travel and how far to move, by a series of integral action pulses. Thus, the COMMANDER 350 does not need to know the absolute regulator position and is unaffected when regulator reaches the upper or lower limit, as determined by the regulator's limit switches (giving rise to the term 'boundless').

When a deviation from set point is introduced the regulator is driven, for a length of time equivalent to the proportional step. The regulator is then driven by integral action pulses until the deviation is within the deadband setting.

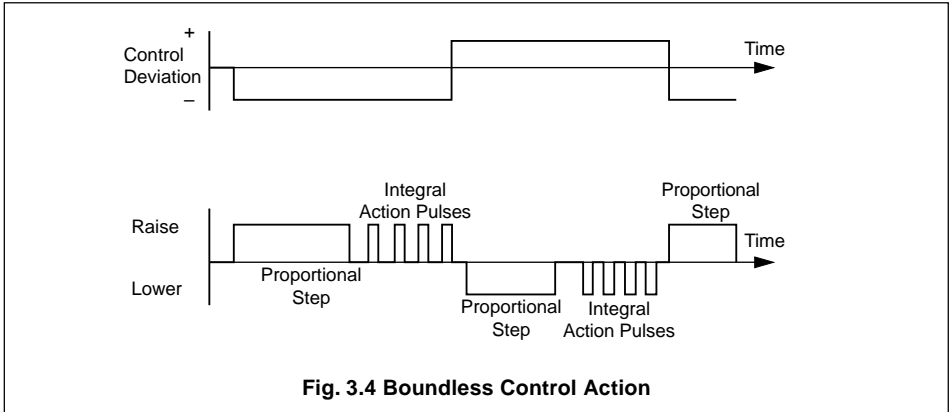

#### Calculation for Control Pulses (Boundless Control)

The following calculations are shown for guidance when setting deadband, proportional and integral values. They can be used to check the suitability of boundless control for a particular actuator/application.

Minimum 'ON' time of integral action pulses (for a fixed control deviation).

$$= \frac{\text{Travel Time} \times \text{Deadband \%}}{\% \text{ Proportional Band}} \text{ (in seconds)}$$

Minimum (approximate) time between integral action pulses (for a fixed control deviation)

$$= \frac{\text{Integral Action Time} \times \text{Deadband \%}}{2 \times \% \text{ Control Deviation}} \text{ (in seconds)}$$

Duration of the proportional step

$$= 2 \times \left[ \frac{\% \text{ Control Deviation}}{\% \text{ Proportional Band}} \right] \times \text{Travel Time in Seconds}$$

% Control Deviation

$$= \frac{\text{Set Point} - \text{Process Variable}}{\text{Eng Hi} - \text{Eng Lo}} \times 100\%$$

% Deadband

$$= \frac{\text{Deadband (eng units)}}{\text{Eng Hi} - \text{Eng Lo}} \times 100\%$$



### ...3.5.2 Valve Setup – Boundless

5.00...5.04

5.00

 LEUS  
 ULUE

5.03

 dbnd  
 0

[In engineering units]

5.04

 rtrU  
 0



[1 to 5000 seconds]

 LEUS  
 ULUE

#### Level 5 – Valve Setup

\* **Note.** To select this frame from anywhere in this page, press and hold the key for a few seconds.

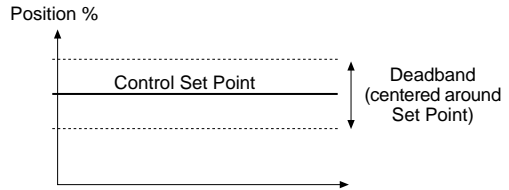
#### Boundless Deadband



#### Regulator Travel Time

The time taken for the regulator to travel from the fully open to the fully closed position.

Return to top of page.



## 4.1 Introduction

To access the Configuration mode (Levels 6 to E) the correct password must be entered in the security code frame.

**Note.** When in the configuration mode, the green bargraph led illuminates. All relays and digital outputs are de-energized and all analog outputs revert to the set minimum current output.

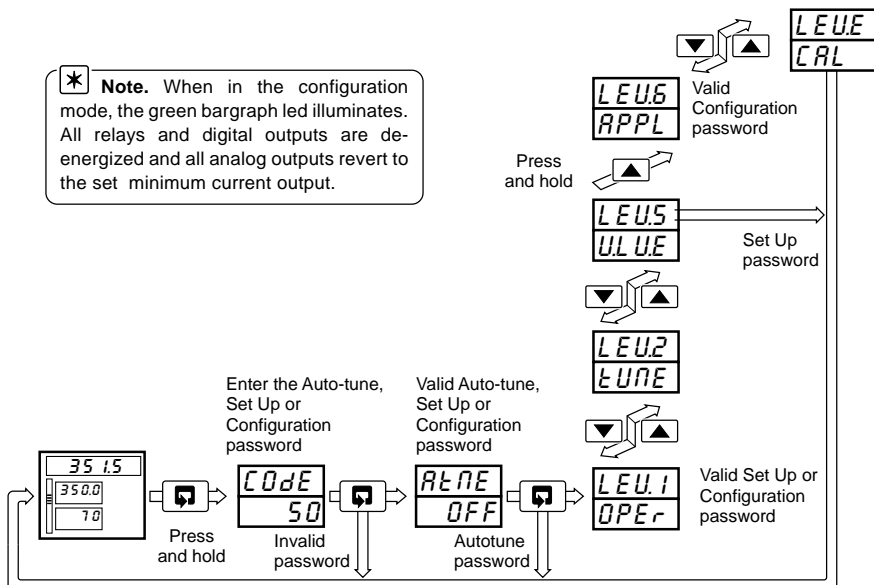

**LEU.6**  
**APPL**

**Basic Configuration**  
Template application  
Output type  
Control action  
Mains rejection frequency

**LEU.7**  
**INPE**

**Analog Inputs 1 to 3**  
Type  
Electrical range  
Decimal places  
Engineering range  
Broken sensor drive  
Input filter time constant

**LEU.8**  
**ALr**

**Alarms 1 to 8**  
Type  
Trip level  
Hysteresis band

**LEU.9**  
**SELP**

**Set Points**  
Tracking enable  
Set point limits  
Local set point sources 1 to 4  
Local/remote set point selection

**LEU.A**  
**CAL**

**Control Configuration**  
Power fail recovery action  
Output high/low limits  
Slew rate + disable  
Configured outputs 1 to 3  
Manual output selection sources  
Auto mode selection source  
Tune parameter sources 1 to 4

**LEU.b**  
**OPER**

**Operator Configuration**  
Auto/manual key enables  
Local/remote key enables  
Alarm acknowledge key enable  
Operator set point adjust enable  
Operator ratio/bias enable  
Password settings  
Clock settings

**LEU.C**  
**ASSN**

**Output Assignment**  
Outputs 1 and 2 type  
Digital output  
Assignment source  
Polarity  
Analog output  
Assignment source  
Electrical range  
Engineering range  
Relay outputs 1 to 4  
Assignment source  
Polarity

**LEU.d**  
**SErL**

**Serial Communications**  
2-/4-wire connection  
2400/9600/19200 baud rate  
Parity  
Modbus address

**LEU.E**  
**CAL**

**Calibration**  
Offset/span adjustment  
Motorized valve feedback

Fig. 4.1 Configuration Mode – Summary





## 4.2 Level 6 – Basic Configuration

6.00...6.01

6.00

LEU6  
APPL

6.01

LAPP  
15L

## Level 6 – Basic Configuration

## Template Application

Templates are provided to make the basic configuration for a particular application as simple as possible. The appropriate template should be selected before any other parameters are configured. When a template is selected, the COMMANDER 350 assumes the preset form for that template (see Appendix A). The inputs and software blocks are automatically soft-wired to perform the selected function.

Select the Template required

Display	Template Description
0 15L	Single loop with local set point only
0 25L	Single loop with remote set point
0 3R_	Auto/Manual station with low signal selection
0 4R_	Auto/Manual station with digital selection
0 5Rb	Analog backup with low signal selection
0 5Rb	Analog backup with digital selection
0 7. 1I	Single indicator/manual loader
0 8. 1I	Double indicator/manual loader



**Note 1.** When a template is selected, the following default values apply: The 'Analog Input Type' of all inputs used by the template defaults to '2', i.e. 4 to 20mA; The engineering ranges of all inputs used default to '0.0 to 100.0'. All other inputs are set to '0FF'.



**Note 2.** Templates customized using the PC Configurator are identified by the letter 'U' in the template code – i.e. template '0 15L' becomes '0 1U'.

Continued...

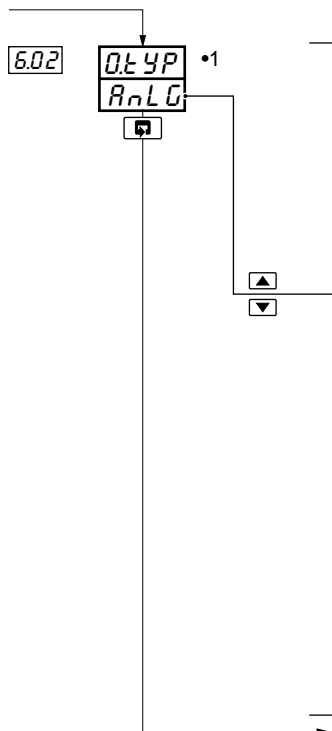

**Control Output Type**

The appropriate relays, digital outputs and analog outputs are assigned to the control output variables. The other hardware outputs are provisionally assigned to alarm and retransmission functions but these may be changed in the output assignment level – see Section 4.8.

Select the Output Type required – see also Fig. 4.2 overleaf and Rear Fold-out/ Table B.

Display	Output Type
<i>nOnE</i>	None
<i>RnLG</i>	Analog output (Control output = ao1)
<i>rLY</i>	Relay output (Control output = RLY1)
<i>dIG</i>	Digital output (Control output = do1)
<i>PFb</i>	Motorized valve with feedback (Open = RLY1, Close = RLY2) •2
<i>bNd</i>	Motorized valve without feedback (Open = RLY1, Close = RLY2)
<i>HCrr</i>	Heat/cool with OP1 = relay, OP2 = relay
<i>HCrd</i>	Heat/cool with OP1 = relay, OP2 = digital output
<i>HCdr</i>	Heat/cool with OP1 = digital output, OP2 = relay
<i>HCRR</i>	Heat/cool with OP1 = analog, OP2 = relay
<i>HCRA</i>	Heat/cool with OP1 = analog, OP2 = analog

Continued...

- 1 Only output types '*nOnE*' and '*RnLG*' are applicable to indicator templates. Only output type '*RnLG*' is applicable to auto/manual station and analog backup templates.
- 2 Analog Input 3 Type defaults to '11' – Resistance Feedback.



...4.2 Level 6 – Basic Configuration

Output Types:

<i>RRLL</i>
<i>rLY</i>
<i>dIG</i>

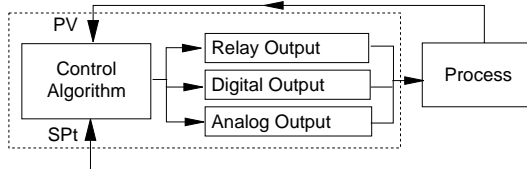

A – Single Output

Output Type:

<i>PFb</i>
------------

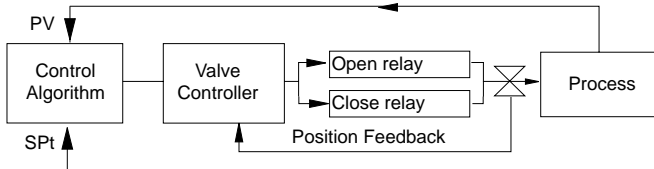

B – Motorized Valve Output with Feedback

Output Type:

<i>bnd</i>
------------

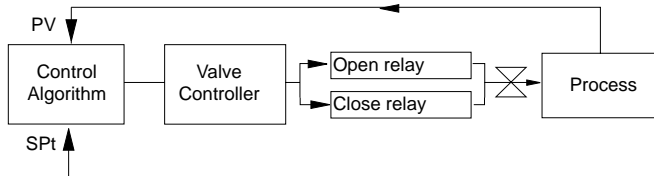

C – Motorized Valve Output without Feedback (Boundless)

Output Types:

<i>HCrr</i>
<i>HCrd</i>
<i>HCdr</i>
<i>HCRR</i>
<i>HCRR</i>

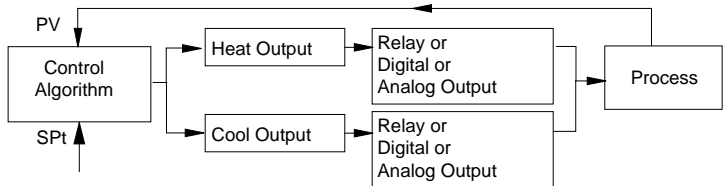

D – Heat/cool Output

Fig 4.2 Output Type Schematic Diagrams

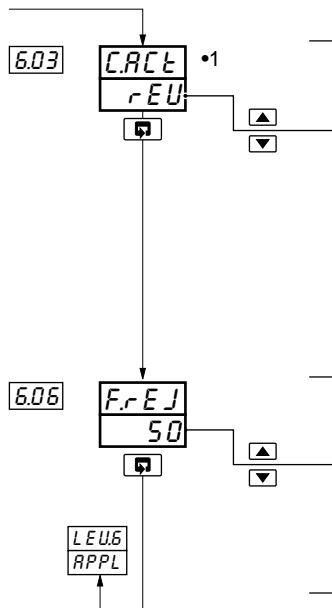

Control Action

	Single Loop	Output 1	
•2	r E U.	Reverse	
•2	d i r	Direct	
	Heat/Cool	Output 1 (Heat)	Output 2 (Cool)
•3	r - d	Reverse	Direct
•3	r - r	Reverse	Reverse
•3	d - r	Direct	Reverse
•3	d - d	Direct	Direct

Mains Rejection Frequency

Used to filter mains frequency pick-up on external analog input wiring.

[50 or 60Hz]

Return to top of page.

- 1 Not displayed for auto/manual or indicator templates.
- 2 Not displayed if Heat/Cool output types selected – see parameter 6.02.
- 3 Displayed only if Heat/Cool output types selected – see parameter 6.02.



## 4.3 Level 7 – Analog Inputs

7.00...7.03

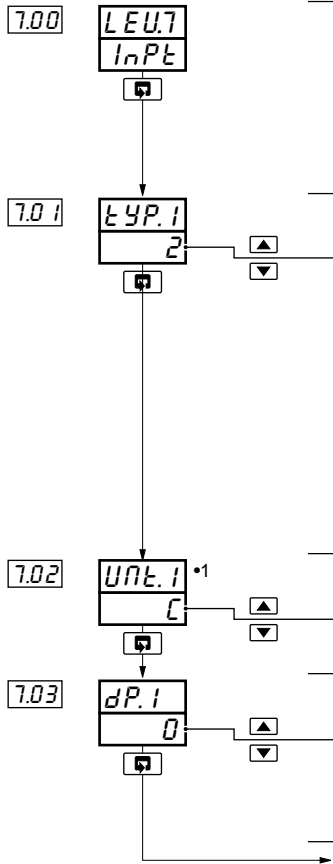

## Level 7 – Analog Inputs

- \* **Note 1.** Refer also to Rear Foldout/Table A, Template Applications.
- \* **Note 2.** To select this frame from anywhere in this page, press the key for a few seconds.

## Analog Input 1 (I/P1) Type &amp; Electrical Range

Display	Description	Display	Description
OFF	Not Used	P	PT100 RTD
b	THC Type B	i	0 to 20mA
E	THC Type E	2	4 to 20mA
J	THC Type J	3	0 to 5V
K	THC Type K	4	1 to 5V
L	THC Type L	5	0 to 50mV
N	THC Type N	7	4 to 20mA square root linearizer
R	THC Type R	8	4 to 20mA power 3/2
S	THC Type S	9	4 to 20mA power 5/2
t	THC Type T	U	Custom

## Temperature Units (I/P1)

- C – THC/PT100 readings displayed in °C
- F – THC/PT100 readings displayed in °F

## Decimal Places (Engineering Range, I/P1)

- 0 – XXXX
- 1 – XXX.X
- 2 – XX.XX
- 3 – X.XXX

Continued...

\*1 Displayed only if THC or RTD input types are selected



... 4.3 Level 7 – Analog Inputs

7.04...7.07

7.04

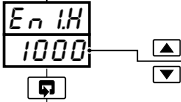

Engineering High (I/P1)

[-999 to 9999]

**\*** Note. This parameter defaults to the maximum allowed value when THC or RTD inputs are selected – see Table 4.1.

THC/RTD Type	°C			°F		
	Min.	Max.	Min. Span	Min.	Max.	Min. Span
Type B	-18	1800	710	0	3272	1278
Type E	-100	900	45	-148	1652	81
Type J	-100	900	50	-148	1652	90
Type K	-100	1300	65	-148	2372	117
Type L	-100	900	50	-148	1652	90
Type N	-200	1300	90	-328	2372	162
Type R & S	-18	1700	320	0	3092	576
Type T	-250	300	60	-418	572	108
Pt100	-250	600	25	-328	1112	45

Table 4.1 Engineering Limits, THC & RTD Inputs

7.05

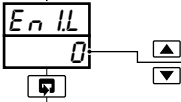

Engineering Low (I/P1)

[-999 to 9999]

**\*** Note. This parameter defaults to the minimum allowed value when THC or RTD inputs are selected – see Table 4.1.

7.06

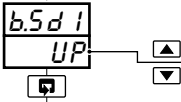

Broken Sensor Drive (I/P1)

- none* – No action. Actual input values remain valid.
- UP* – Input driven to the maximum upscale value (999)
- dN* – Input driven to the minimum downscale value (-999)

In the event of a fault being detected on the input, the input is driven in the direction selected.

7.07

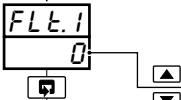

Input Filter Time Constant (I/P1)

The input values are averaged over the time set.

[0 to 60 seconds]

Continued...



... 4.3 Level 7 – Analog Inputs

7.08...7.14

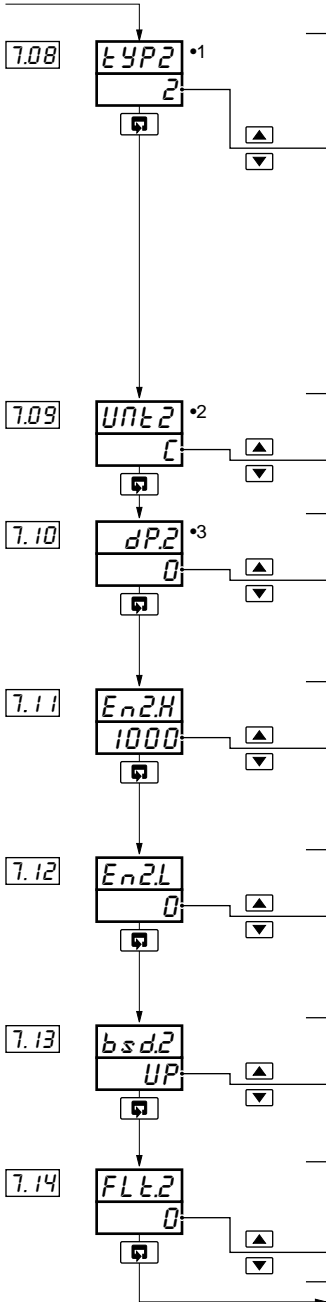

Analog Input Type & Electrical Range (I/P2)

\* Note. THC inputs can only be used on I/P2 if I/P1 is also set to THC.

Display	Description	Display	Description
OFF	Not Used	t	THC Type 1
b	THC Type B	i	0 to 20mA
E	THC Type E	2	4 to 20mA
J	THC Type J	5	0 to 50mV
K	THC Type K	7	4 to 20mA square root linearizer
L	THC Type L	8	4 to 20mA power 3/2
n	THC Type N	9	4 to 20mA power 5/2
r	THC Type R	U	Custom
S	THC Type S		

Temperature Units (I/P2)

C – THC readings displayed in °C  
 F – THC readings displayed in °F

Decimal Places (Engineering Range, I/P2)

0 – XXXX  
 1 – XXX.X  
 2 – XX.XX  
 3 – X.XXX

Engineering High (I/P2)

[-999 to 9999]

\* Note. This parameter defaults to the maximum allowed value when THC input type is selected – see Table 4.1.

Engineering Low (I/P2)

[-999 to 9999]

\* Note. This parameter defaults to the minimum allowed value when THC input is selected – see Table 4.1.

Broken Sensor Drive (I/P2)

none – No action. Actual input values remain valid.  
 UP – Input driven to the maximum upscale value (999)  
 dN – Input driven to the minimum downscale value (-999)

Filter Time Constant (I/P2)

The input values are averaged over the time set.

[0 to 60 seconds]

Continued...

- 1 Frames 7.09 to 7.14 are not displayed if Analog Input Type 2 is set to 'OFF'.
- 2 Displayed only if THC input type is selected.
- 3 When i/p 2 is assigned to a remote set point input, it is displayed with the same number of decimal places as the associated process variable.



... 4.3 Level 7 – Analog Inputs

7.1 5...7.21

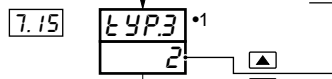

Analog Input Type & Electrical Range (I/P3)

Display	Description	Display	Description
<i>OFF</i>	Not Used	<i>1</i>	0 to 20mA
<i>b</i>	THC Type B	<i>2</i>	4 to 20mA
<i>E</i>	THC Type E	<i>3</i>	0 to 5V
<i>J</i>	THC Type J	<i>4</i>	1 to 5V
<i>K</i>	THC Type K	<i>6</i>	0 to 50mV
<i>L</i>	THC Type L	<i>7</i>	4 to 20mA square root linearizer
<i>N</i>	THC Type N	<i>8</i>	4 to 20mA power 3/2
<i>R</i>	THC Type R	<i>9</i>	4 to 20mA power 5/2
<i>S</i>	THC Type S	<i>ii</i>	Resistance feedback for motorized valve
<i>t</i>	THC Type T	<i>U</i>	Custom
<i>P</i>	PT100 RTD		

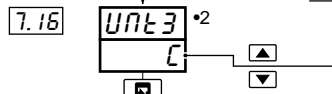

Temperature Units

*C* – THC readings displayed in °C  
*F* – THC readings displayed in °F

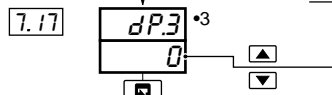

Decimal Places

*0* – XXXX  
*1* – XXX.X  
*2* – XX.XX  
*3* – X.XXX

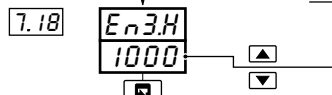

Engineering High

[–999 to 9999]

**\*** **Note.** This parameter defaults to the maximum allowed value when THC or RTD inputs are selected – see Table 4.1.

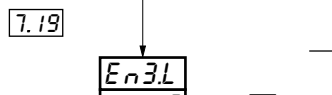

Engineering Low

[–999 to 9999]

**\*** **Note.** This parameter defaults to the minimum allowed value when THC or RTD inputs are selected – see Table 4.1.

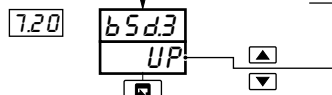

Broken Sensor Drive (I/P3)

*none* – No action. Actual input values remain valid.  
*UP* – Input driven to the maximum upscale value (999)  
*dN* – Input driven to the minimum downscale value (–999)

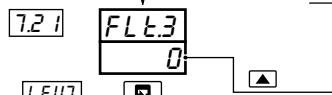

Filter Time Constant (I/P3)

The input values are averaged over the time set.

[0 to 60 seconds]

Return to top of page.



- 1 Frames 7.16 to 7.21 are not displayed if Analog Input Type 3 is set to 'OFF'.
- 2 Displayed only if THC or RTD input types are selected.
- 3 When i/p 2 is assigned to a remote set point input, it is displayed with the same number of decimal places as the associated process variable.





### 4.4 Level 8 – Alarms

\* **Note.** Any type of alarm can be used to sound an annunciator (klaxon/horn) which is disabled when the alarm is acknowledged. This is achieved by assigning the relay to the acknowledge state of the alarm instead of the actual alarm state.

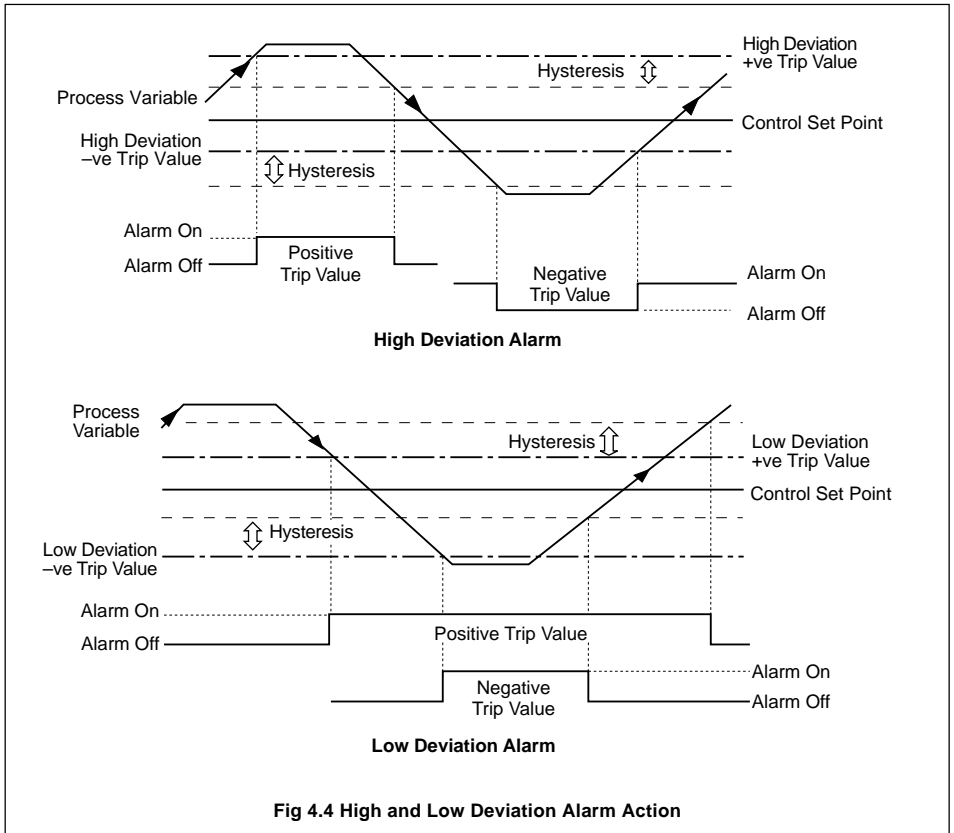
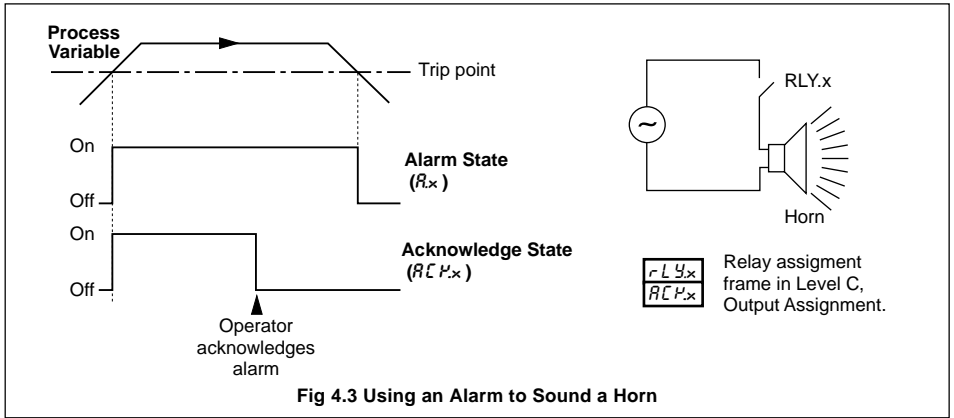



...4.4 Level 8 – Alarms

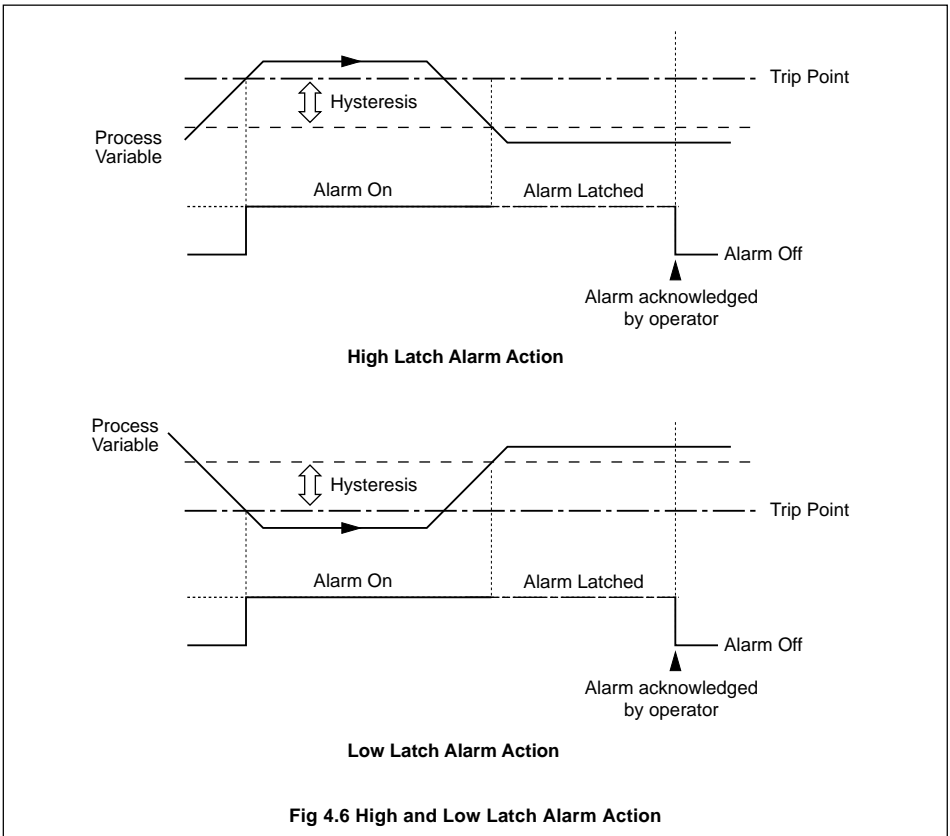
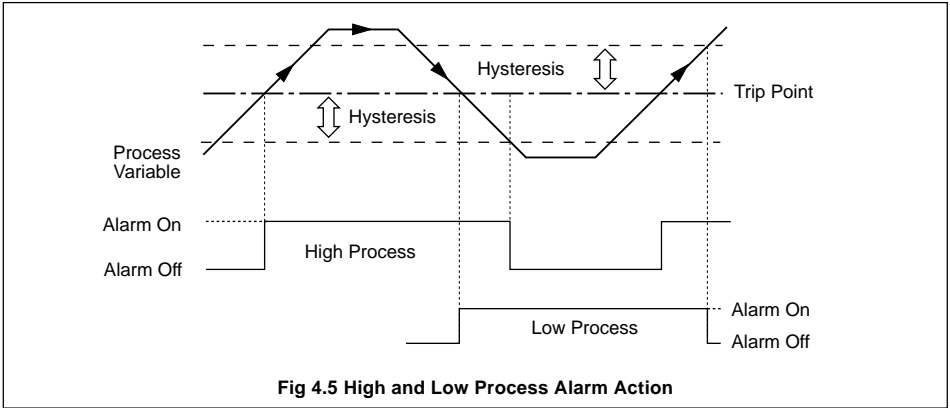



## ...4.4 Level 8 – Alarms

8.00...8.03

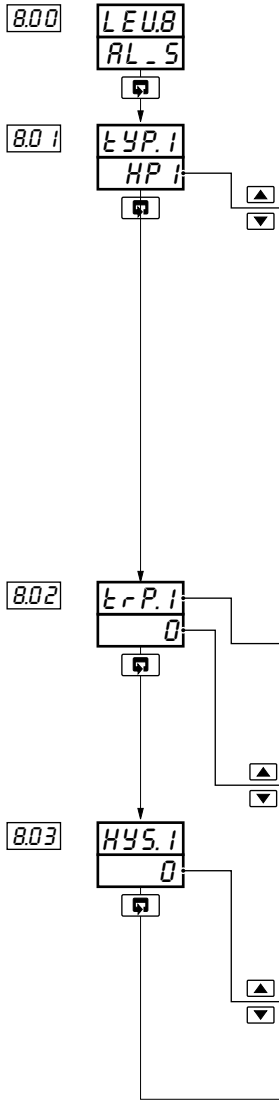

## Level 8 – Alarms

\* **Note.** To select this frame from anywhere in this page, press the key for a few seconds.

## Alarm 1 Type

See Figs 4.3 to 4.6

Display	Description	Display	Description
<i>none</i>	None	<i>LP3</i>	Low Process I/P3
<i>HPU</i>	High Process, PV	<i>HO</i>	High Output •1
<i>LPU</i>	Low Process, PV	<i>LO</i>	Low Output •1
<i>HLP</i>	High Latch, PV	<i>Hb 1</i>	Math Block 1 High
<i>LLP</i>	Low Latch, PV	<i>Lb 1</i>	Math Block 1 Low
<i>Hd</i>	High Deviation	<i>Hb 2</i>	Math Block 2 High
<i>Ld</i>	Low Deviation	<i>Lb 2</i>	Math Block 2 Low
<i>HP 1</i>	High Process I/P1	<i>Hb 3</i>	Math Block 3 High
<i>LP 1</i>	Low Process I/P1	<i>Lb 3</i>	Math Block 3 Low
<i>HP 2</i>	High Process I/P2	<i>Hb 4</i>	Math Block 4 High
<i>LP 2</i>	Low Process I/P2	<i>Lb 4</i>	Math Block 4 Low
<i>HP 3</i>	High Process I/P3		

\* **Note.** Alarm 1 is set automatically as a Low Process alarm on I/P2 when template 3 or 5 is selected.

## Alarm 1 Trip

## Alarm Number

## Trip Value

[In engineering units]

## Alarm 1 Hysteresis

Set the hysteresis value (in engineering units) for Alarm 1.

The alarm is activated at the trip level but is only deactivated when the process variable has moved into the safe region by an amount equal to the hysteresis value – see Figs. 4.4 to 4.6.

[In engineering units]

\* **Note.** Time hysteresis is set using the PC Configurator.

Continued...

•1 Applies to the PID output with single or heat/cool output types selected – see Section 3.4.



... 4.4 Level 8 – Alarms

8.04...8.25

- 8.04
- 8.07
- 8.10
- 8.13
- 8.16
- 8.19
- 8.22

TYPE  
NONE

Alarm Type 2 (Alarms 2 to 8)

[see Alarm 1 Type]

- 8.05
- 8.08
- 8.11
- 8.14
- 8.17
- 8.20
- 8.23

TRIP  
0

Alarm 2 to Alarm 8 Trip

Alarm Number and Type

[see Alarm 1 Trip]

Trip Value

[In engineering units]

- 8.06
- 8.09
- 8.12
- 8.15
- 8.18
- 8.21
- 8.24

HYS.  
0

Alarm 2 to Alarm 8 Hysteresis

Set the hysteresis value (in engineering units) – see Alarm 1 Hysteresis.

[In engineering units]

- 8.25

GRAB.  
NONE

Global Alarm Acknowledge Source

**\*** Note. This frame is applicable only to issue 4 and later software.

All active and unacknowledged alarms can be acknowledged by a single digital input.

Set the source required to acknowledge all alarms

See Rear Fold-out/ Table C – Digital Sources.

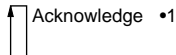

LEU.B  
AL-5

Return to top of page.

•1 A digital input becomes active when a volt-free contact is closed or a low TTL signal is applied.



## 4.5 Level 9 – Set Point Configuration

9.00...9.03

\* **Note.** Level 9 is not applicable when an Indicator template (templates 7 and 8) or an Auto/Manual station template (templates 3 and 4) is selected.

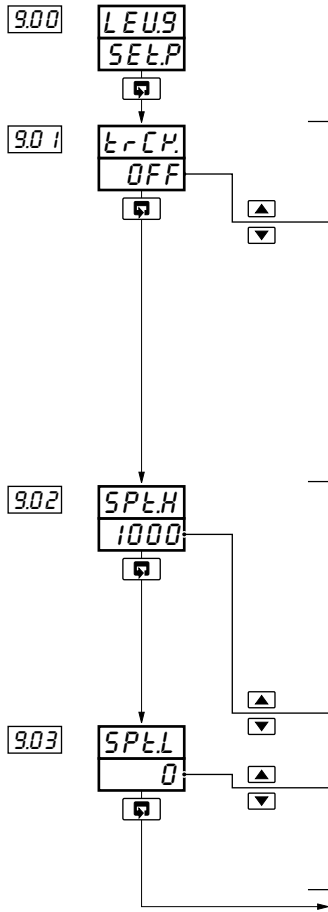

## Level 9 – Set Point Configuration

\* **Note.** To select this frame from anywhere in this page, press and hold the key for a few seconds.

## Set Point Tracking Enable

Display	Local Set Point Tracking	Remote Set Point Tracking	
OFF	OFF	OFF	
LDC	ON	OFF	
rE	OFF	ON	•1
L-r	ON	ON	•1

**Local Set Point Tracking** – the local set point tracks the process variable when manual mode is selected.

**Remote Set Point Tracking** – local set point tracks the remote set point when in remote set point mode. If the controller is put into manual mode the set point reverts from remote to local.

## Set Point Limits

The set point limits define the maximum and minimum values to which the local and/or remote set points can be adjusted. The set point limits do not apply when in Manual mode with local set point tracking enabled. If the set point is outside its limits when Automatic mode is selected, the set point value can only be adjusted towards its limits. Once within the limits they apply as normal.

## Control Set Point (CSPT) High Limit

[–999 to 9999 in engineering units]

## Control Set Point (CSPT) Low Limit

[–999 to 9999 in engineering units]

\* **Note.** Operator level adjustment of the set point can be disabled – see Section 4.7, Operator Configuration/ Set Point Adjustment Enable.

Continued...

•1 Only available if a remote set point template is selected.



...4.5 Level 9 – Set Point Configuration

9.05...9.11

9.06

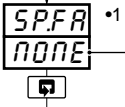

**Remote Set Point Fault Action**

The action required when a fault occurs with the remote set point.

- none* – No action
- LOC* – Select local set point mode
- dFLt* – Select local set point mode and set to the default value

9.07

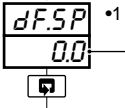

**Local Set Point Default Value**

Set the value required for the local set point under remote set point fault conditions.

[In engineering units]

9.08

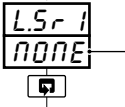

**Local Set Point Source 1**

The source required to select local set point 1 (LSP1) as the current local set point.

See Rear Fold-out/ Table C – Digital Sources.

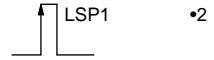

9.09

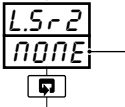

**Local Set Point Source 2**

The source required to select local set point 2 (LSP2) as the current local set point.

See Rear Fold-out/ Table C – Digital Sources.

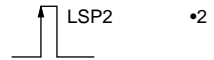

9.10

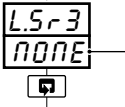

**Local Set Point Source 3**

The source required to select local set point 3 (LSP3) as the current local set point.

See Rear Fold-out/ Table C – Digital Sources.

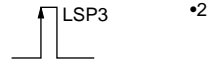

9.11

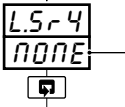

**Local Set Point Source 4**

The source required to select local set point 4 (LSP4) as the current local set point.

See Rear Fold-out/ Table C – Digital Sources.

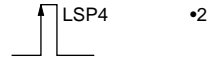

Continued...

•1 Displayed only if a remote set point template is selected.

•2 A digital input becomes active when a volt-free contact is closed or a low TTL signal is applied.



...4.5 Level 9 – Set Point Configuration

9.12...9.14

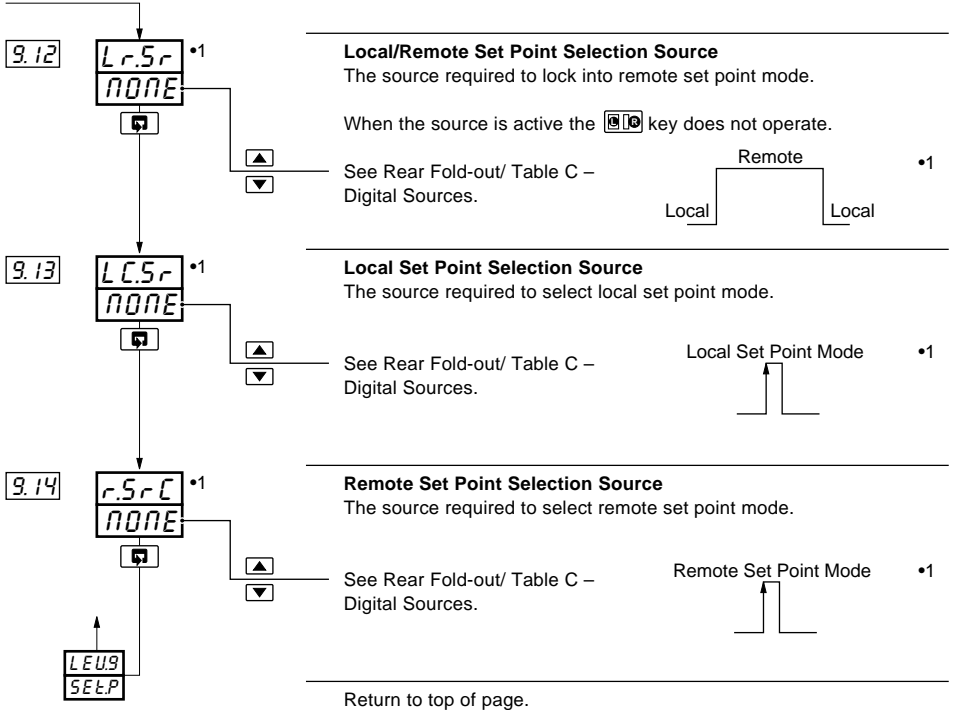

•1 Digital inputs are active when a volt-free contact is closed or a low TTL signal is applied



### 4.6 Level A – Control Configuration

R.00...R.02

**\*** **Note.** Level A is not displayed if an indicator template is selected.



#### Level A – Control Configuration

**\*** **Note.** To select this frame from anywhere in this page, press and hold the key for a few seconds.

#### Power Fail Recovery Mode

Select the default power failure mode required following a power interruption or failure.

Display	Setting	Display	Setting
0	Last mode	5	Auto mode, integral term reset
1	Manual mode, using last output	6	Auto mode, using last integral term
2	Manual mode with 0.0% output	7	Power outage ≤ Recovery time: Auto mode. Power outage > Recovery time: Manual mode, last output
3	Manual mode with 100.0% output	8	Power outage ≤ Recovery time: Auto mode. Power outage > Recovery time: Manual mode, configured output
4	Manual mode with configured output		

#### Recovery Time

If power is restored within the recovery time, the controller continues in the last mode when power fail recovery modes 7 or 8 are selected.

[0 to 9999 seconds]

Continued...

\*1 Not displayed if power fail modes 0 to 6 are selected.





## ...4.6 Level A – Control Configuration

R.03...R.08

**R.03** **PUFA**  
none

**Process Variable Fail Action**  
Determines controller output when the process variable input fails.

none – No action  
HOLD – Put into Manual mode  
dflt – Put into Manual mode and select default output

---

**R.04** **DFOP**  
0

**Default Output**  
This output is used in conjunction with Power Recovery mode 8 and Process Variable Fail action.

[0 to 100%] (–100% to +100% for heat/cool)

---

**R.05** **DPH1** \*1  
100

**Output High Limit – Single Output Control**  
Limits the high level of the control output in automatic mode. If the control output is above this limit when automatic mode is selected, the current output value becomes the high limit until the value falls below the limit set.

[0.0 to 100.0%]

---

**R.06** **DPL0** \*1  
0

**Output Low Limit – Single Output Control**  
Limits the low level of the control output in automatic mode. If the control output is below this limit when automatic mode is selected, the current output value becomes the low limit until the value rises above the limit set.

[0.0 to 100.0%]

---

**R.07** **OP1H** \*2  
100.0

**Output 1 (Heat) High Limit – Heat/Cool Control**  
Limits the high level of control output 1 in automatic mode. If the control output is above this limit when automatic mode is selected, the current output value becomes the high limit until the value falls below the limit set.

[0.0 to 100.0%]

---

**R.08** **OP2H** \*2  
100

**Output 2 (Cool) High Limit – Heat/Cool Control**  
Limits the high level of control output 2 in automatic mode, when 'reverse-direct' or 'direct-reverse' control action selected in the Basic Configuration level. If the control output is above this limit when automatic mode is selected, the current output value becomes the high limit until the value falls below the limit set.

[0.0 to –100.0%]

Continued...

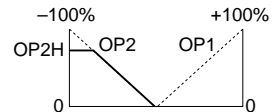

- 1 Displayed only if a single output type is selected.
- 2 Displayed only if a heat/cool output type is selected.



...4.6 Level A – Control Configuration

R.09...R.12

R.09

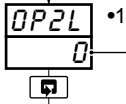

**Output 2 (Cool) Low Limit – Heat/Cool Control**

Limits the low level of control output 2 in automatic mode, when 'reverse-reverse' or 'direct-direct' control action is selected in the Basic Configuration level. If the control output is below this limit when automatic mode is selected, the current output value becomes the low limit until the value rises above the limit set.

[0 to 100%]

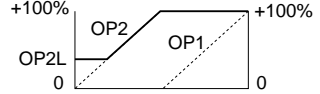

R.10



**Output Slew Rate**

The maximum rate of change of the control output (or both control outputs for heat/cool).

[0.01 to 99.99% change per second or 'OFF']

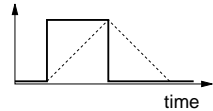

**Note.** The default slew rate setting is applied to both increasing and decreasing output values. The slew rate setting can be applied to either increasing values only or decreasing values only using the PC Configurator.

R.11

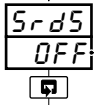

**Slew Rate Disable Source**

The digital source required to disable slew rate control of the output. See Rear Fold-out/ Table C – Digital Sources.

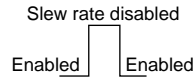

R.12



**Manual 1 Mode Selection Source**

The digital source required to select manual mode and Configured Output 1.

See Rear Fold-out/ Table C – Digital Sources.

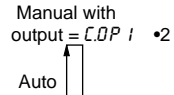

Continued...

- 1 Displayed only if reverse-reverse or direct-direct control actions are selected.
- 2 Digital inputs are active when a volt free contact is closed or a low TTL signal is applied.



## ...4.6 Level A – Control Configuration

R.13...R.17

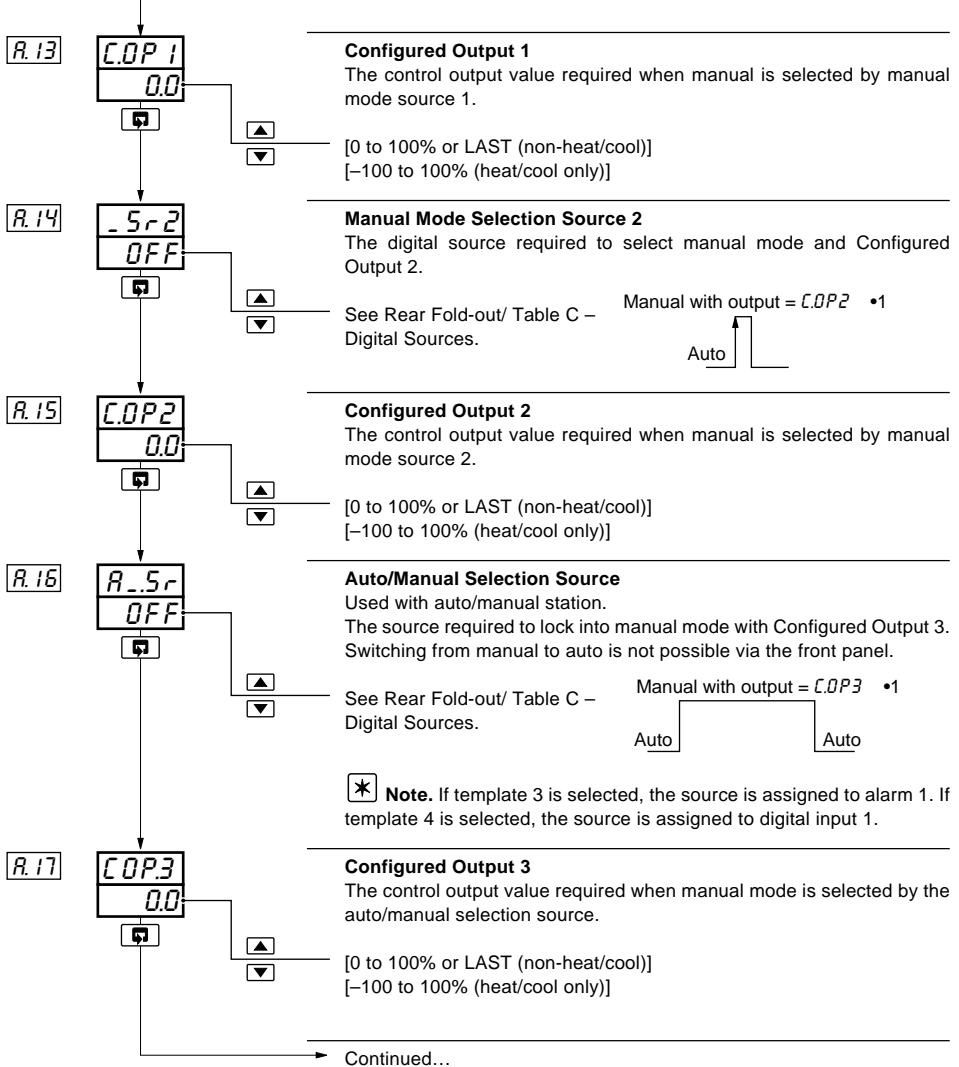

•1 Digital inputs are active when a volt free contact is closed or a low TTL signal is applied



...4.6 Level A – Control Configuration

R.18...R.22

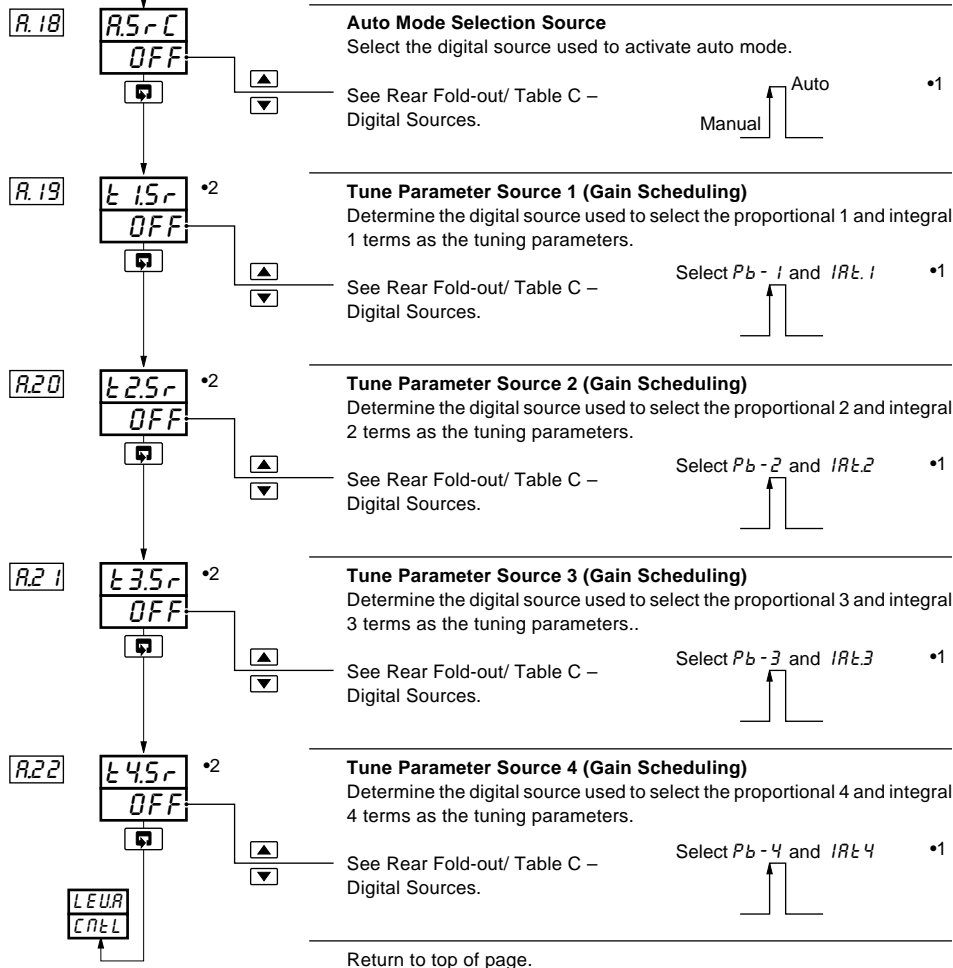

- 1 Digital inputs are active when a volt free contact is closed or a low TTL signal is applied.
- 2  $PB-x$  and  $Int.x$  values are set in Level 2 – see Section 3.2, Tune/Proportional Band x and Integral Action Time x. This function is not applicable to Auto/Manual Station or Indicator templates.



## 4.7 Level B – Operator Configuration

b.00...b.06

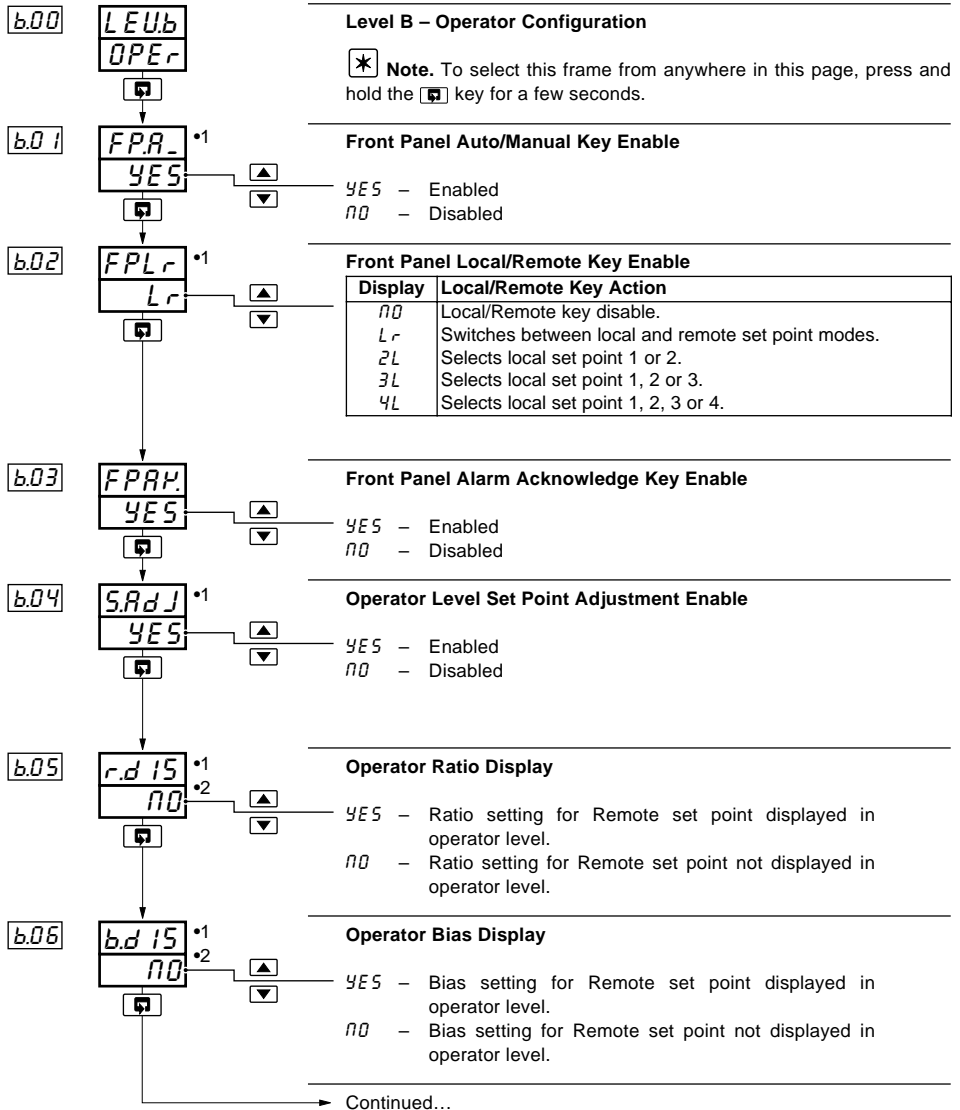

- 1 Not displayed if the Indicator template is in use.
- 2 Displayed only if a template with remote set point is selected.



...4.7 Level B – Operator Configuration

b.07...b.16

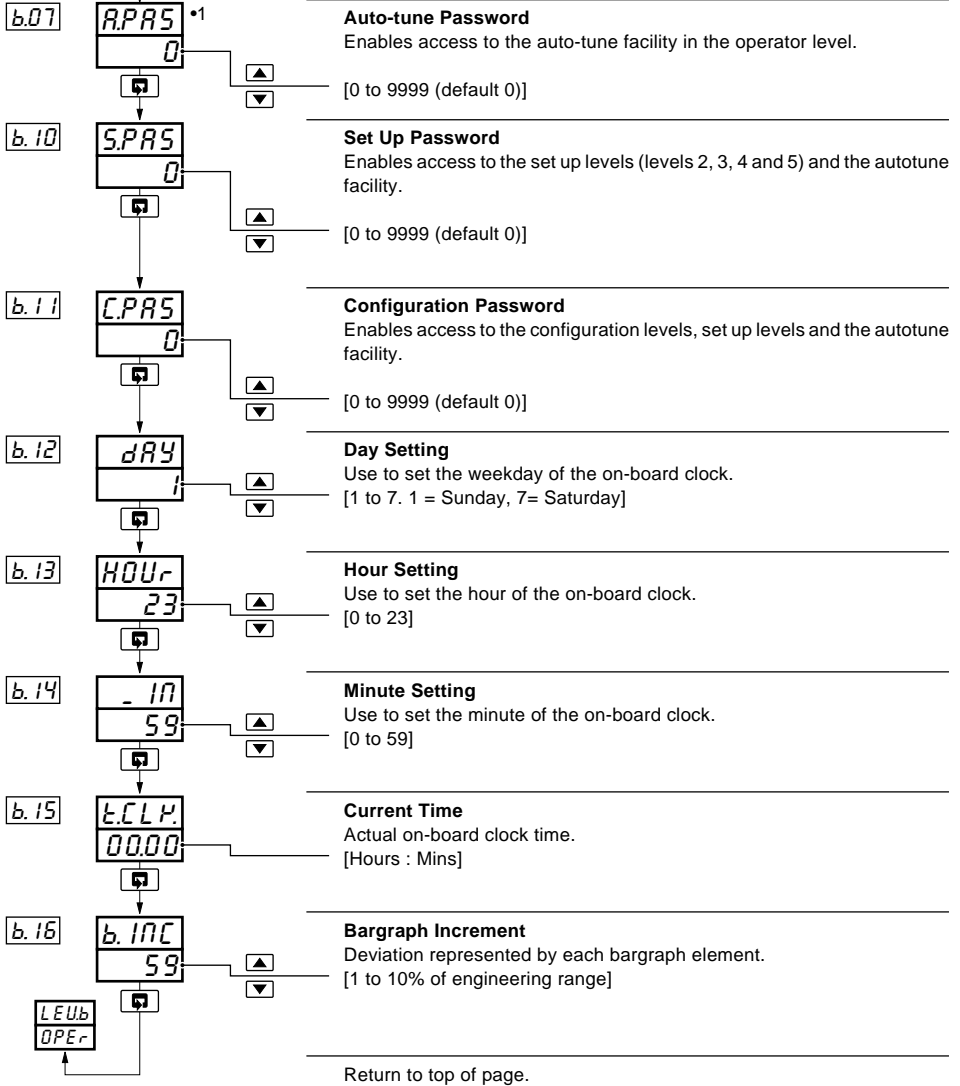

\*1 Not displayed on Indicator or Auto/manual station templates.



## 4.8 Level C – Output Assignment Configuration

C.O0, C.O1

**Note.** The Output Assignment default settings are preconfigured to each template – see Table B, Output Sources on the rear fold-out.

C.O0

LEUC  
RSSn



C.O1

EYP.1 \*1  
ANLG



AN.1A  
NONE

or

dIG



dG.1A  
NONE

### Level C – Output Assignment

**Note.** To select this frame from anywhere in this page, press and hold the key for a few seconds.

### Analog/Digital Output 1 (ao1/do1) Type

Select the output type for Output 1.

ANLG – Analog  
dIG – Digital

Press to advance to Analog Output 1 Assignment Source.

Press to advance to Digital Output 1 Assignment Source.

Continued...

- 1 If the output is assigned to a control output by the control type, the setting displayed cannot be changed – see Section 4.2, Basic Configuration/Control Output Type.



### 4.8.1 Digital Output 1

C07, C08

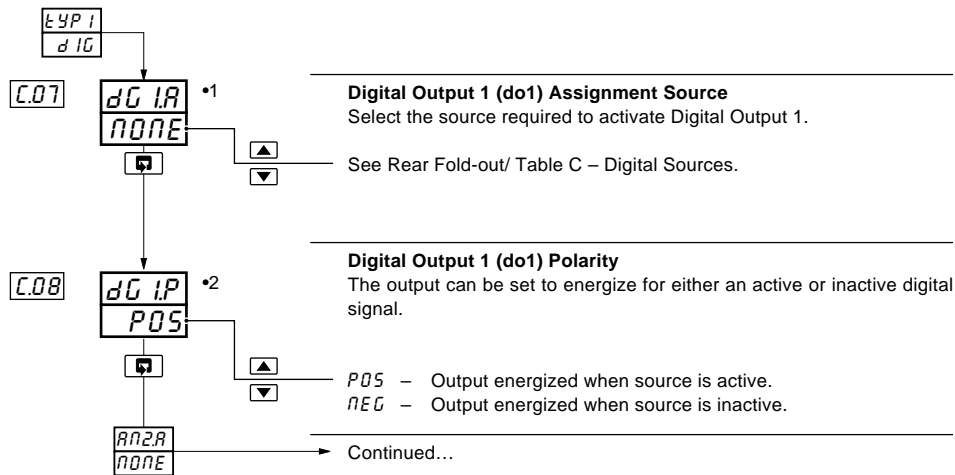

- 1 If the output is assigned to a control output by the control type, the setting displayed cannot be changed – see Section 4.2, Basic Configuration/Control Output Type.
- 2 Not applicable if digital output 1 is assigned to a control output.





## 4.8.2 Analog Output 1

C02...C06

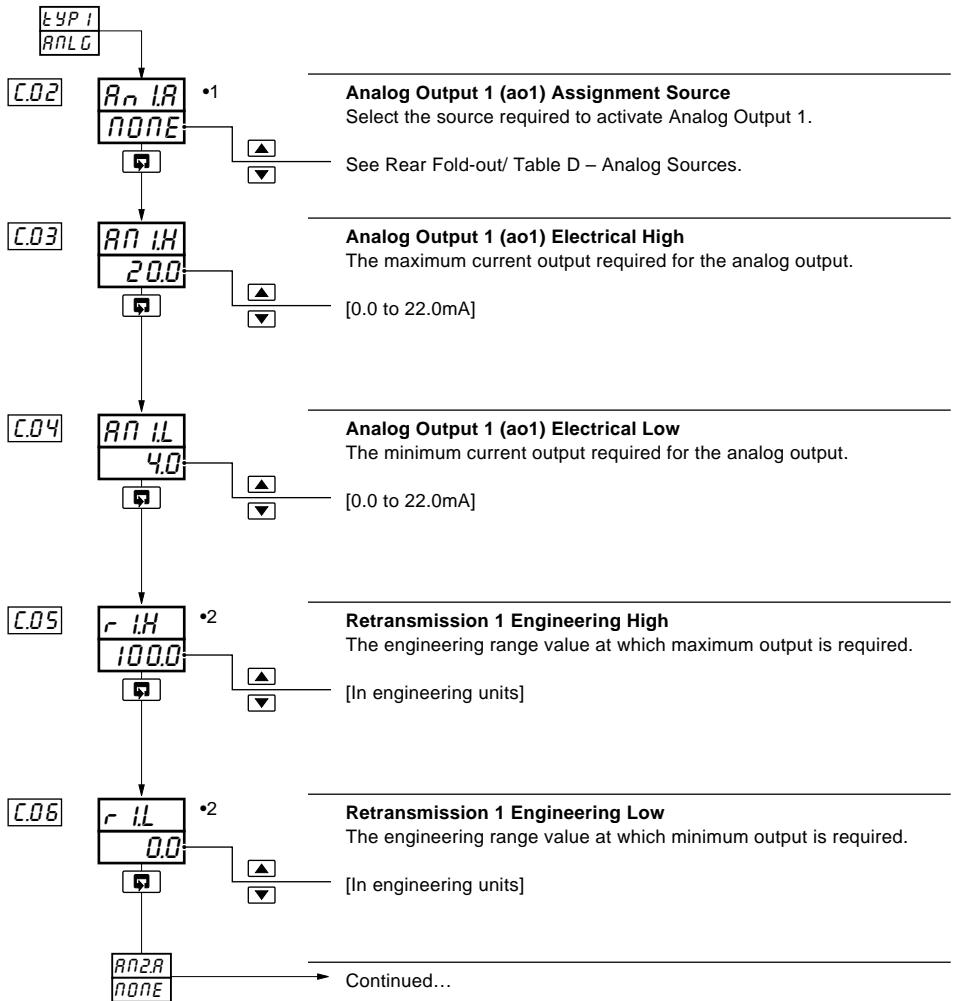

- 1 If the output is assigned to a control output by the control type, the setting displayed cannot be changed – see Section 4.2, Basic Configuration/ Control Output Type.
- 2 Not applicable if analog output 1 is assigned to a control output.



### 4.8.3 Analog Output 2

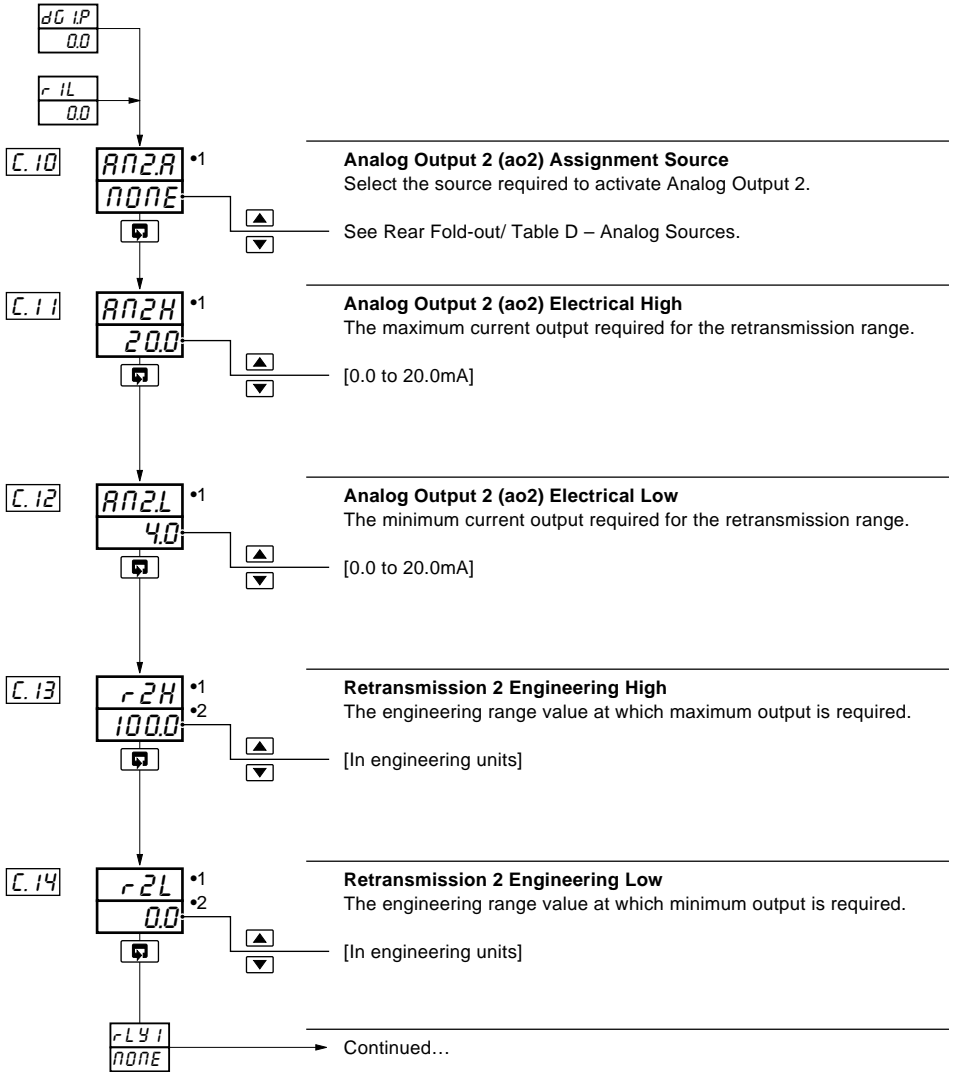

- 1 If the output is assigned to a control output by the control type, the setting displayed cannot be changed – see Section 4.2, Basic Configuration/ Control Output Type.
- 2 Not applicable if analog output 2 is assigned to a control output.



## 4.8.4 Relay Outputs 1 to 4

C17...C22

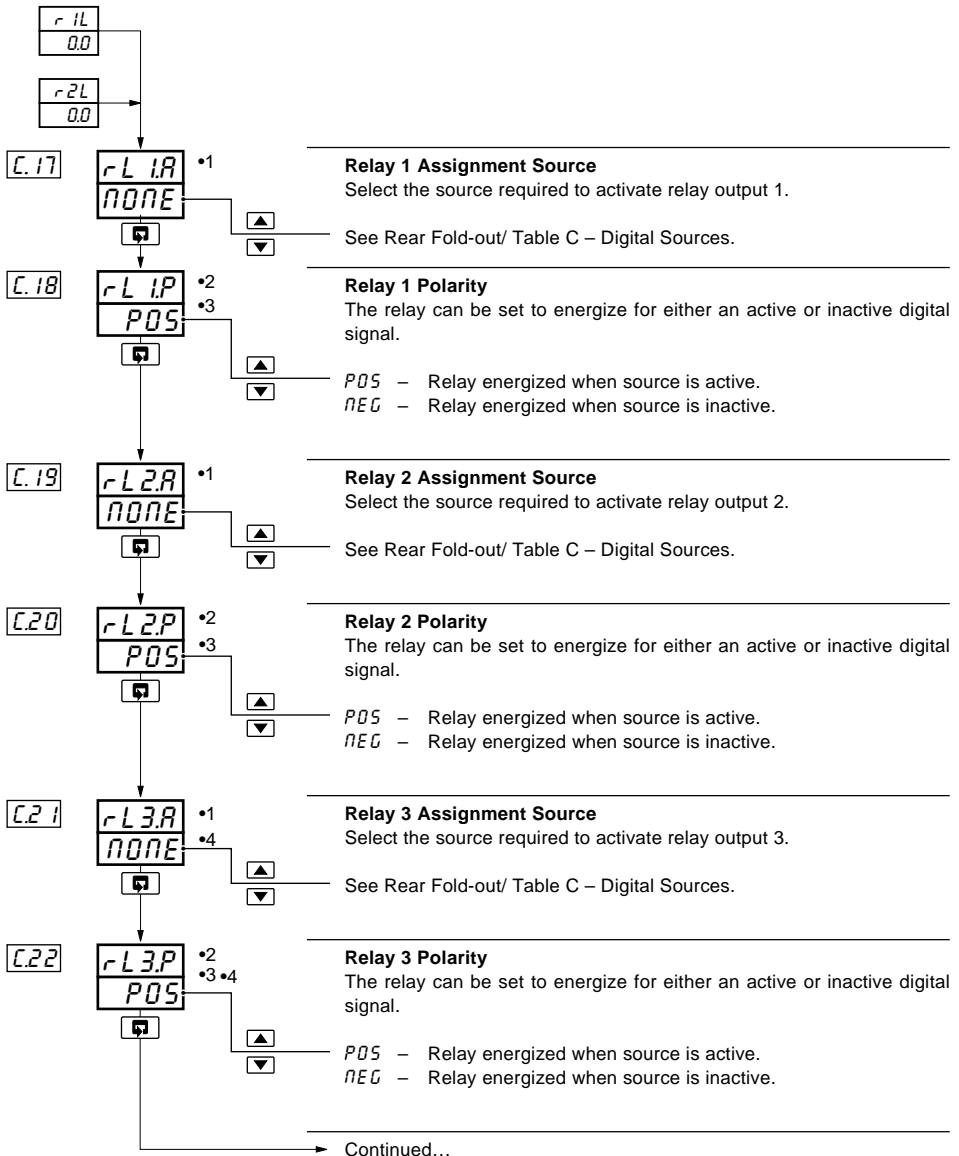

- 1 If the output is assigned to a control output by the control type, the setting displayed cannot be changed – see Section 4.2, Basic Configuration/ Control Output Type.
- 2 Not displayed if relay is assigned to a control output signal.
- 3 Not applicable if relay is assigned to a control output.
- 4 Displayed only if optional relay output is fitted.



...4.8.4 Relay Outputs 1 to 4

C23...C24

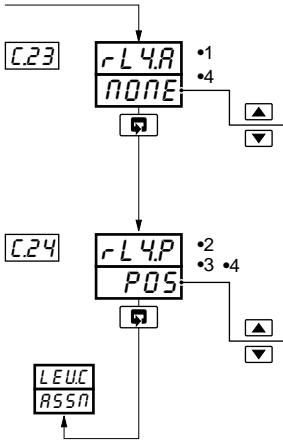

---

**Relay 4 Assignment Source**  
 Select the source required to activate relay output 4.  
 See Rear Fold-out/ Table C – Digital Sources.

---

**Relay 4 Polarity**  
 The relay can be set to energize for either an active or inactive digital signal.

*POS* – Relay energized when source is active.  
*NEG* – Relay energized when source is inactive.

---

Return to top of page.

- 1 If the output is assigned to a control output by the control type, the setting displayed cannot be changed – see Section 4.2, Basic Configuration/ Control Output Type.
- 2 Not displayed if relay is assigned to a control output signal.
- 3 Not applicable if relay is assigned to a control output.
- 4 Displayed only if relay output is fitted.



## 4.9 Level D – Serial Communications Configuration

d.00...d.03

\* **Note.** Level D is only applicable if the serial communications option is fitted.

d.00

LEUd  
SErL



## Level D – Serial Communications Configuration

\* **Note.** To select this frame from anywhere in this page, press and hold the key for a few seconds.

d.01

SCFG  
0



## Serial Configuration

- 0 – Off  
 1 – 2-wire connection, 2400 baud rate  
 2 – 4-wire connection, 2400 baud rate  
 3 – 2-wire connection, 9600 baud rate  
 4 – 4-wire connection, 9600 baud rate  
 5 – 2-wire connection, 19200 baud rate  
 6 – 4-wire connection, 19200 baud rate

d.02

PrtY  
NONE



## Parity

- NONE – None  
 Odd – Odd  
 Even – Even

d.03

Addr  
1



## Modbus™ Address

Each slave on a Modbus link must be assigned a unique address – see *IM/C350-MOD*.

[1 to 99]

LEUd  
SErL

Return to top of page.



### 4.10 Level E – Calibration

E.00...E.04

**\*** Note. This page enables fine tuning of the inputs to eliminate system errors.

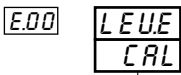

#### Level E – Calibration

**\*** Note. To select this frame from anywhere in this page, press the key for a few seconds.



#### Analog Input 1 Offset Calibration

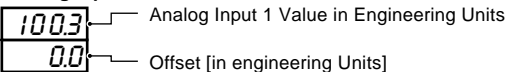

If the and keys are not operated for three seconds the display reverts to the offset value only.

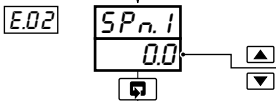

#### Analog Input 1 Span Calibration

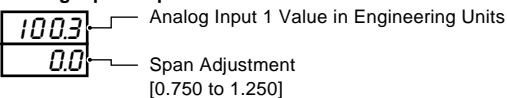

If the and keys are not operated for three seconds the display reverts to the span value only.

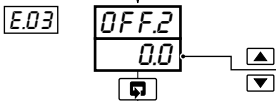

#### Analog Input 2 Offset Calibration

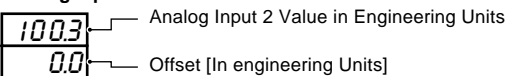

If the and keys are not operated for three seconds the display reverts to the offset value only.

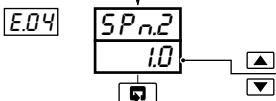

#### Analog Input 2 Span Calibration

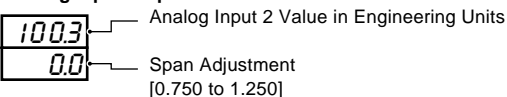

If the and keys are not operated for three seconds the display reverts to the offset value only.

Continued...



## ...4.10 Level E – Calibration

E.05...E.10

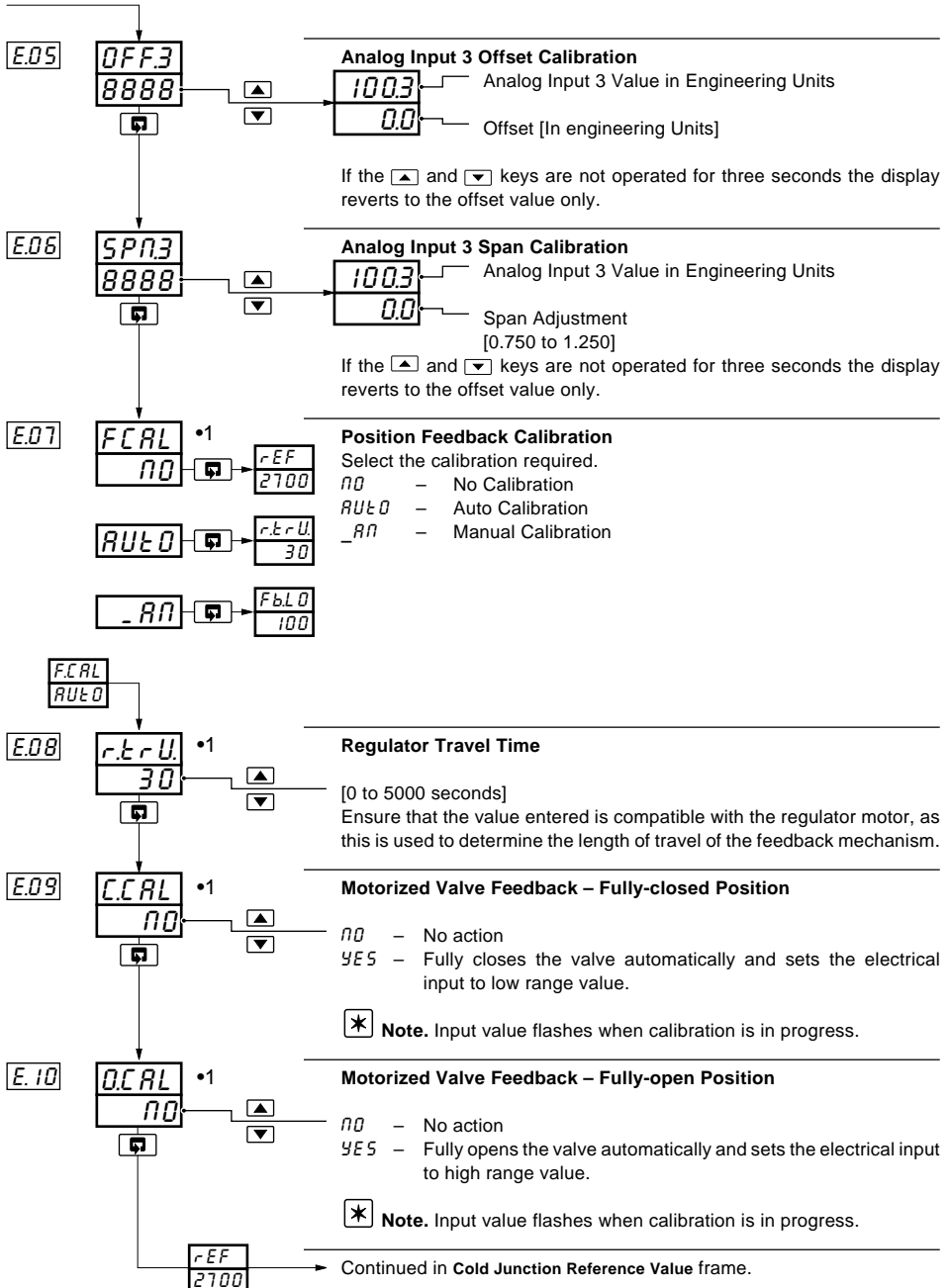

\*1 Displayed only if Motorized Valve with feedback output type is selected – see Section 4.2, Basic Configuration.



...4.10 Level E – Calibration

E.11 ...E.16

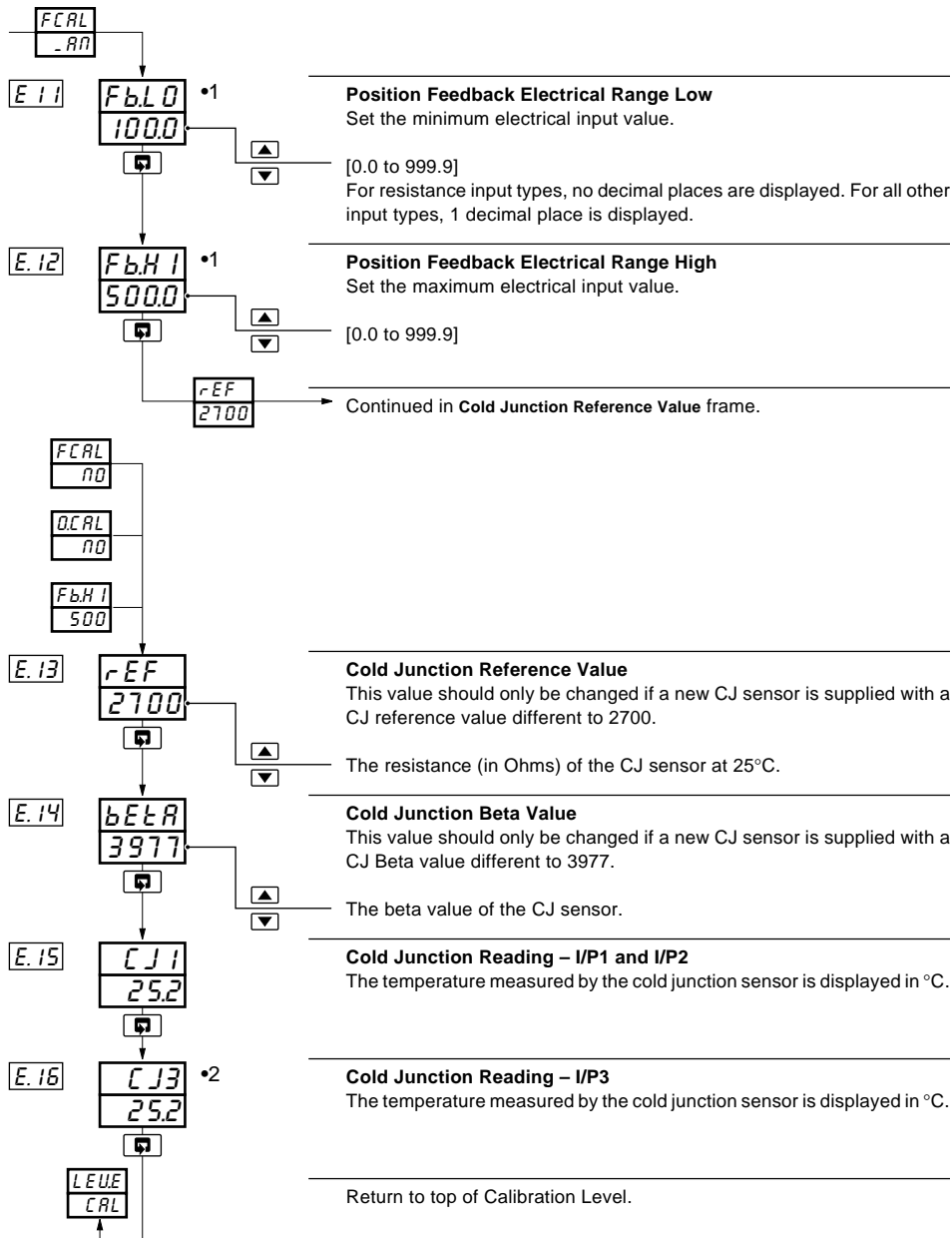

- 1 Displayed only if Motorized Valve with feedback output type is selected – see Section 4.2, Basic Configuration.
- 2 Displayed only if corresponding input type is set to 'THC'.





**EC Directive 89/336/EEC**

In order to meet the requirements of the EC Directive 89/336/EEC for EMC regulations, this product must not be used in a non-industrial environment.

**Cleaning**

Clean only the front panel, using warm water and a mild detergent.

**End of Life Disposal**

This instrument does not contain any substance that will cause undue harm to the environment. However, the unit contains a small lithium battery. This should be removed and disposed of responsibly in accordance with local environmental regulations. The remainder of the unit can be safely considered as normal waste and disposed of accordingly.

**5.1 Mechanical Installation**

**5.1.1 Siting – Figs. 5.1 and 5.2**

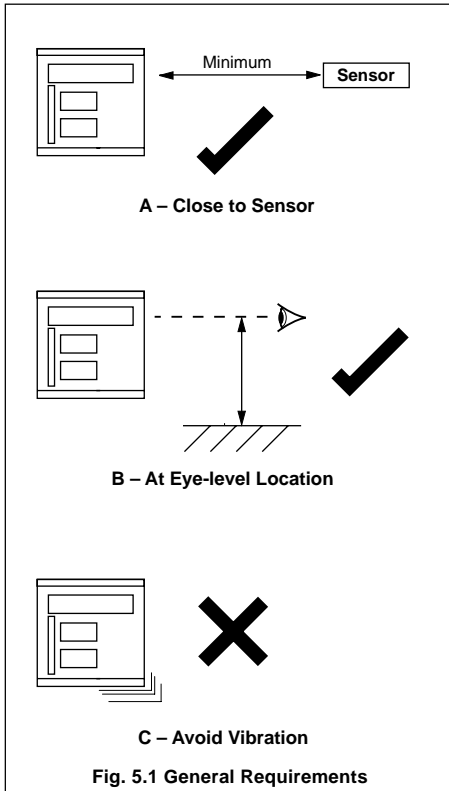

Fig. 5.1 General Requirements

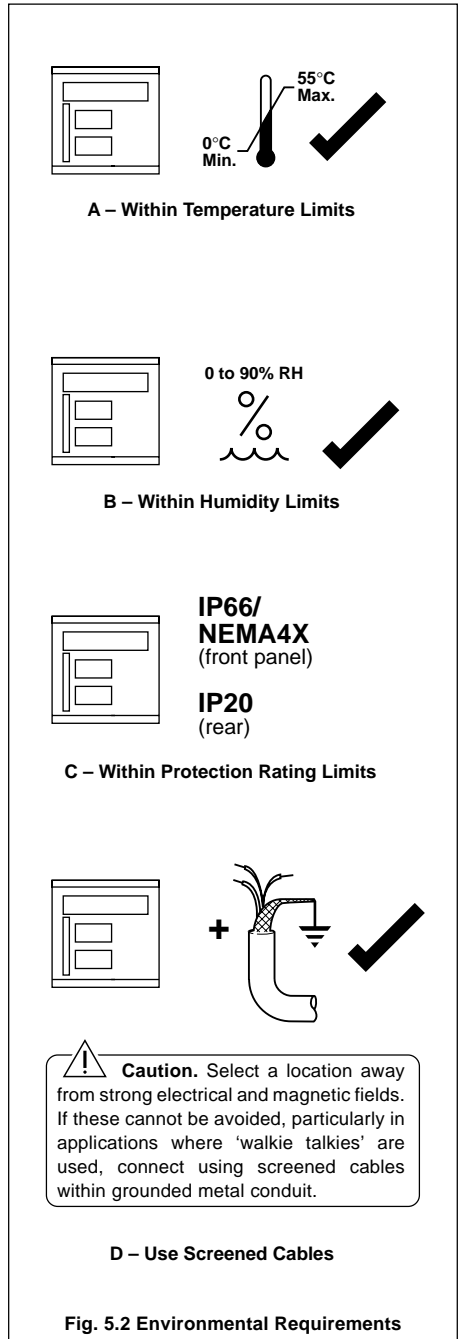

Fig. 5.2 Environmental Requirements



### 5.1.2 Mounting – Figs. 5.3 to 5.5

The instrument is designed for panel mounting (Fig. 5.4). Overall dimensions are shown in Fig. 5.3.

**\* Note.** For NEMA4X protection, a minimum panel thickness of 2.5mm is recommended.

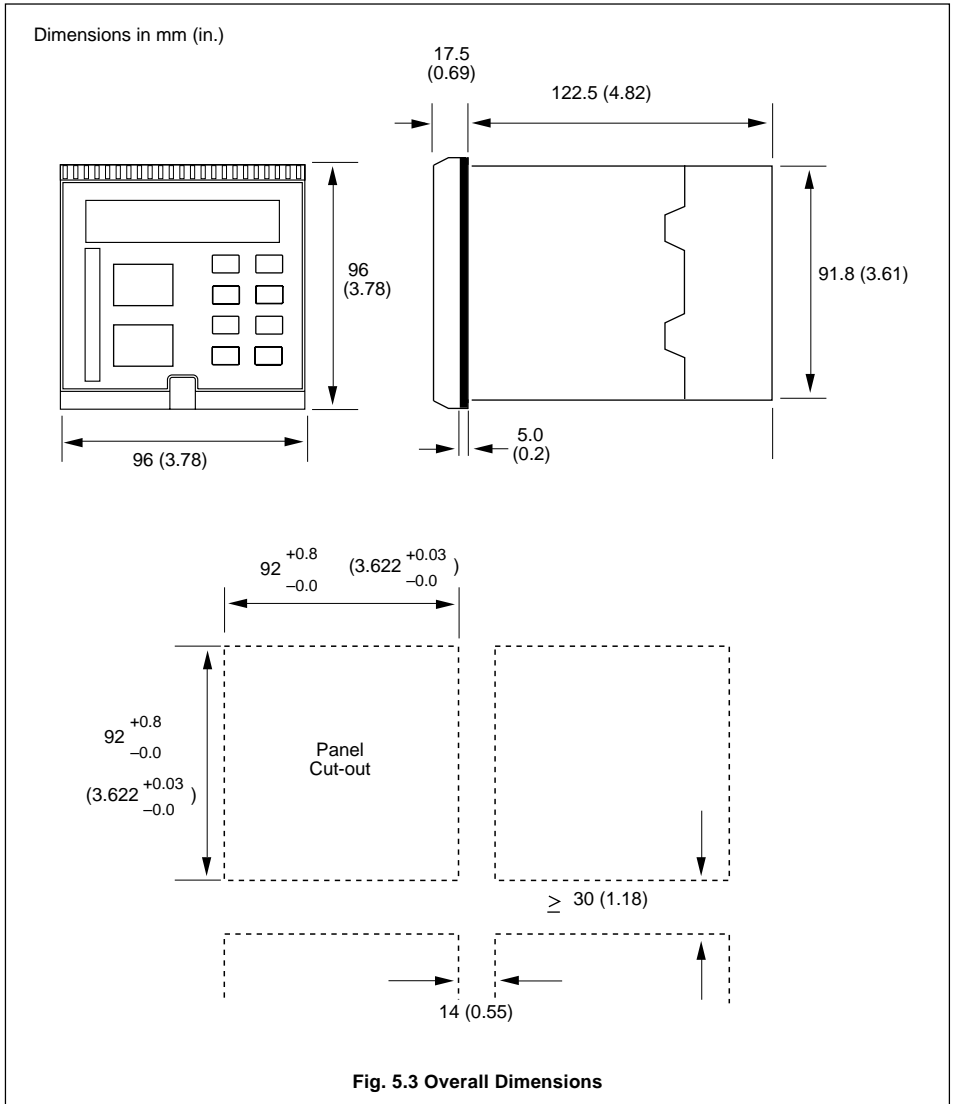



## ...5.1.2 Mounting – Figs. 5.3 to 5.5

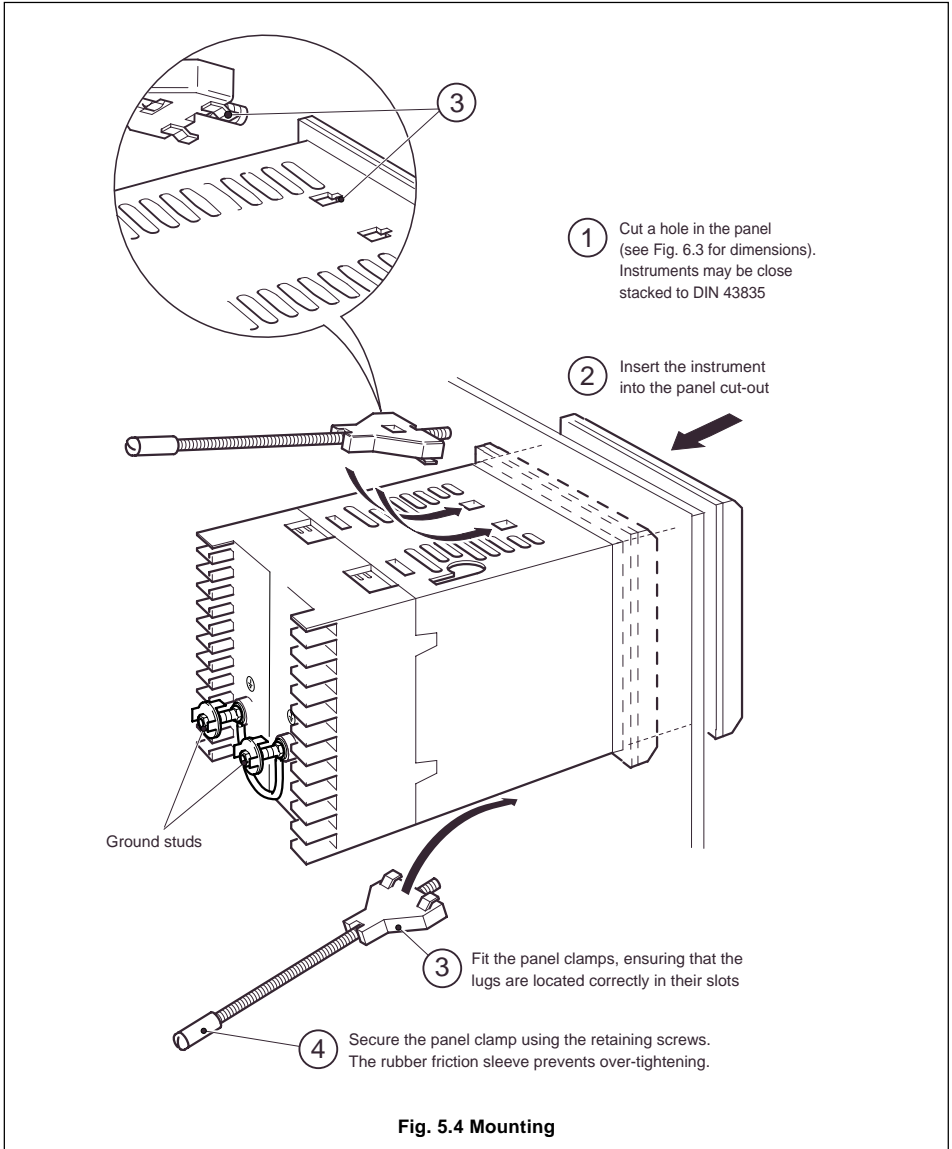



...5.1.2 Mounting – Figs. 5.3 to 5.5

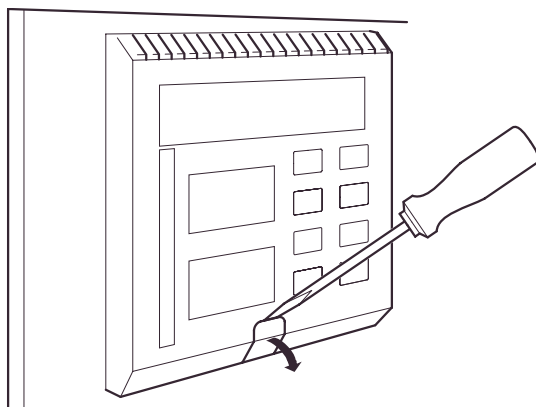

① Release the jacking screw cover

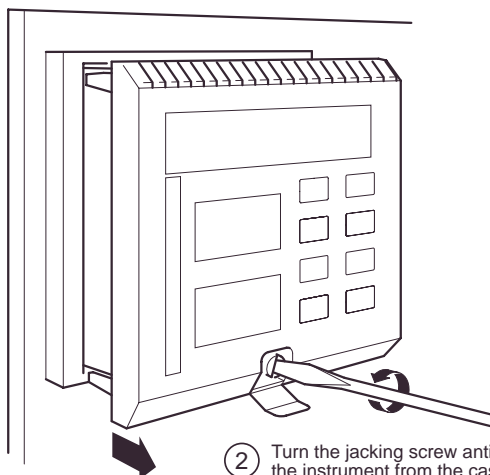

② Turn the jacking screw anticlockwise to pull the instrument from the case



**Note.** Refitting is the reversal of removal.

Fig. 5.5 Inserting/Removing the Instrument from the Case



## 5.2 Electrical Installation

Refer to the Template Applications table and Output Sources table on the rear fold-out to determine the input and output connections to be made.



### Warning.

- The COMMANDER 351 is not fitted with a switch therefore a disconnecting device such as a switch or circuit breaker conforming to local safety standards must be fitted to the final installation. It must be fitted in close proximity to the instrument within easy reach of the operator and must be marked clearly as the disconnection device for the COMMANDER 351.
- Remove all power from supply, relay and any powered control circuits and high common mode voltages before accessing or making any connections.
- Use cable appropriate for the load currents. The terminals accept cables up to 14AWG (2.5mm<sup>2</sup>).
- The COMMANDER 351 conforms to Insulation Category 2, Pollution Degree 2 (EN61010-1).
- All connections to secondary circuits must have basic insulation.
- After installation, there must be no access to live parts e.g. terminals.
- Terminals for external circuits are for use only with equipment with no accessible live parts.



### Caution.

- If the COMMANDER 351 is used in a manner not specified by the Company, the protection provided by the equipment may be impaired.
- All equipment connected to the COMMANDER 351 terminals must comply with local safety standards (IEC 60950, EN61010-1).



### Note.

- Always route signal leads and power cables separately, preferably in grounded metal conduit.
- It is strongly recommended that screened cable is used for signal inputs and relay connections. Connect the screen to the ground stud – see Fig. 5.4.



This equipment is protected through double insulation (Class II).



### 5.2.1 Electrical Connections – Figs 5.6 to 5.8

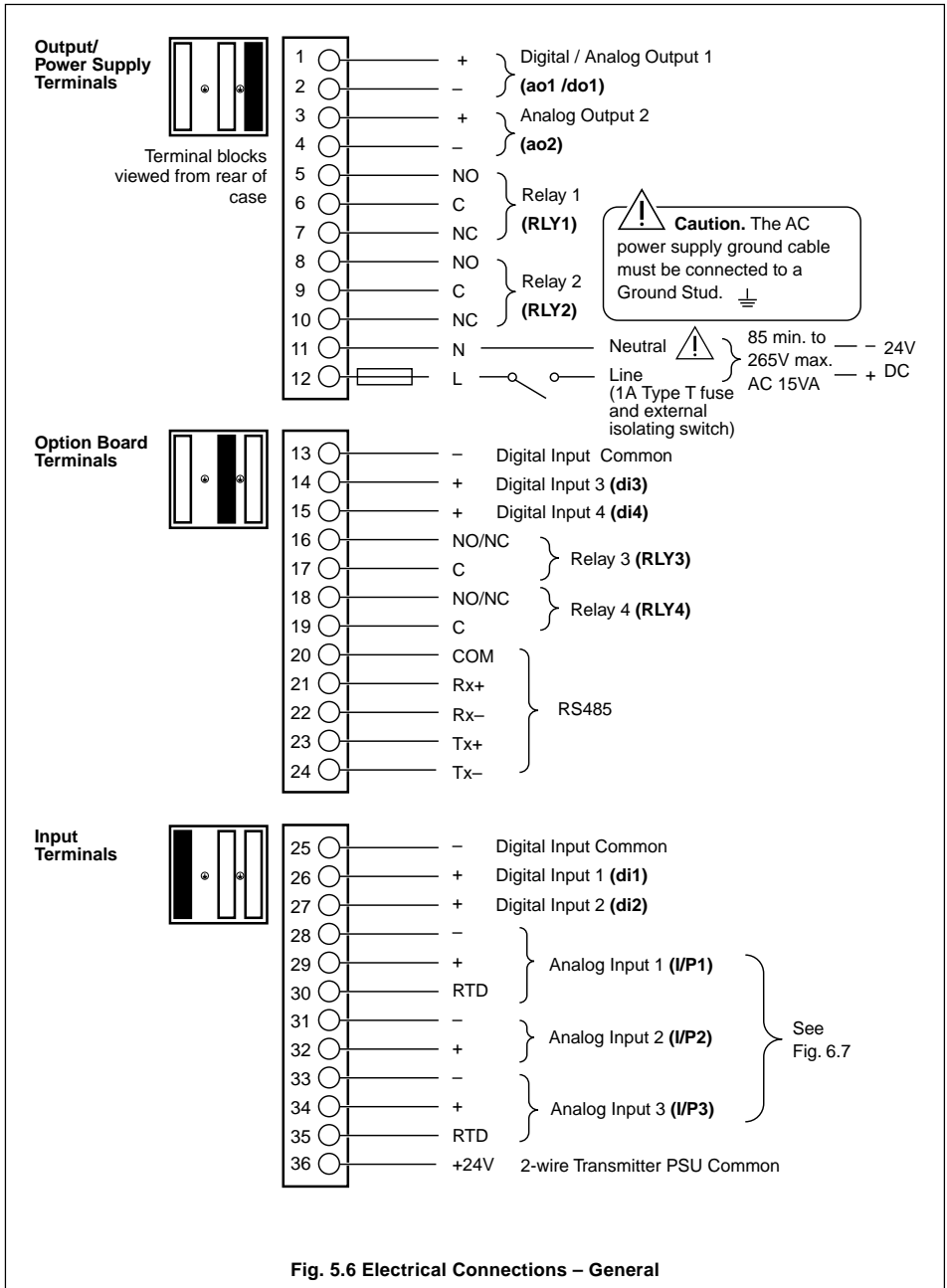
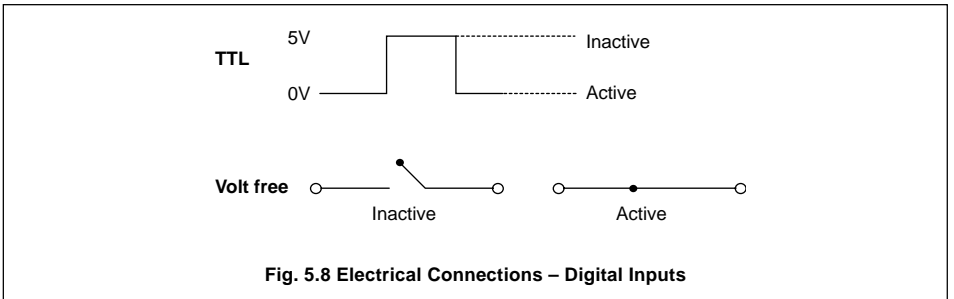
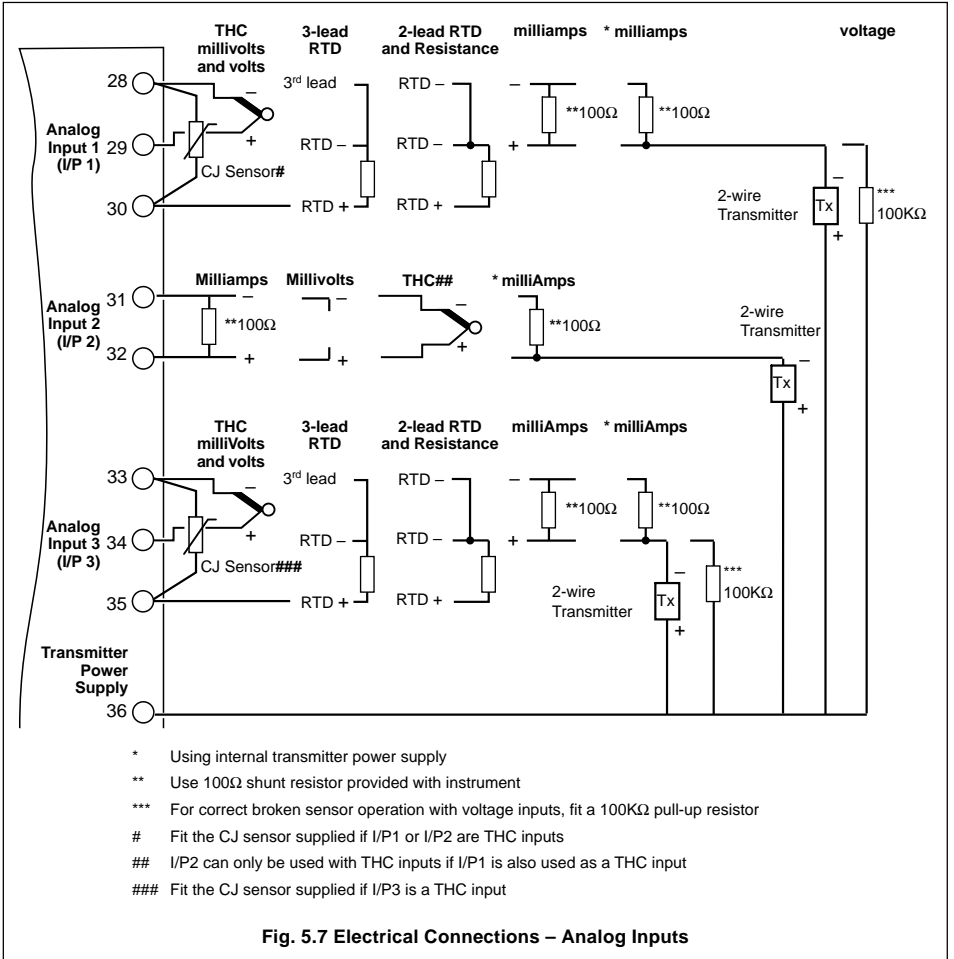

Fig. 5.6 Electrical Connections – General



...5.2.1 Electrical Connections – Figs 5.6 to 5.8



\* **Note.** The battery is a 3 Volt non-replaceable lithium cell.



### 5.3 Relays

\* **Note.** Refer to the Rear Fold-out/ Table B for default relay assignments.

Relay contacts are rated at:  
115/230 V AC at 5 A (non-inductive)  
250 V DC 25 W max.  
A suitable fuse must be fitted.

### 5.4 Digital Output

15 V DC min. at 20 mA  
Min. load 750  $\Omega$

### 5.5 Control or Retransmission Analog Output

Max. load 15 V (750  $\Omega$  at 20 mA).  
Isolated from analog input, dielectric strength  
500 V for 1 minute.

#### 5.3.1 Setting the Relay Links – Fig. 5.9

Set the links on the option board (if fitted).

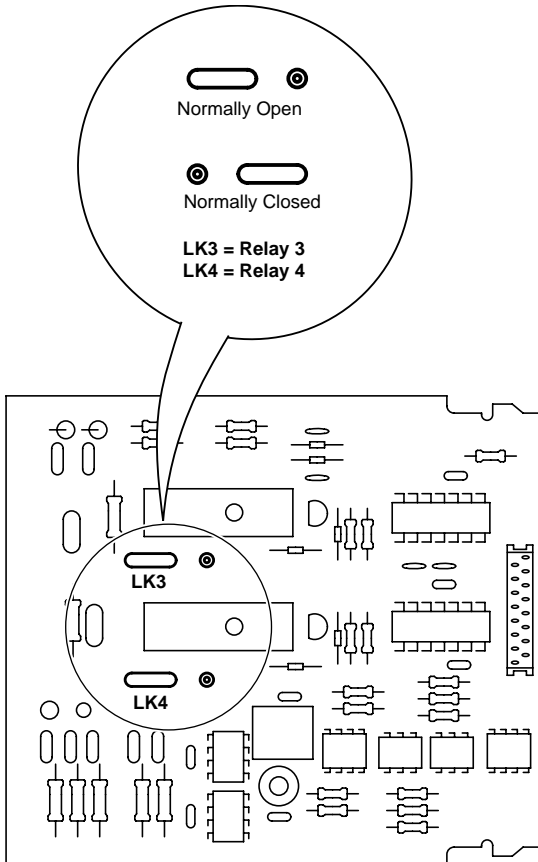

\* **Note.** The default setting for the relay links is 'Normally Open' (N/O).

Fig. 5.9 Relay Links





### 5.6 Motorized Valve Connections – Fig. 5.10

\* **Note.** Relays used to drive the motorized valve must be set for 'Normally Open' operation – see Section 5.3.1.

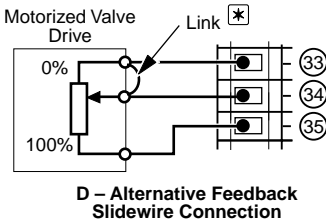
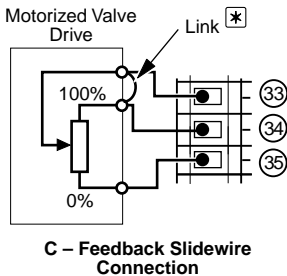
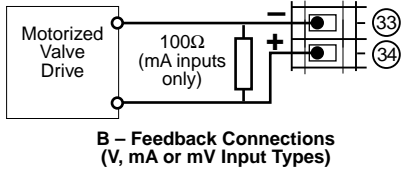
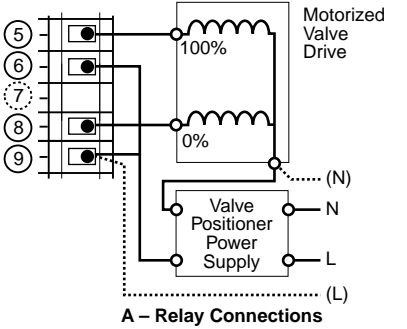

\* **Note.** The wire link must be connected at the motorized valve end, NOT to the instrument terminals.

**Fig. 5.10 Motorized Valve Connections**

### 5.7 Input Connections

Make connections to each input – see Fig 5.7.

*Refer to Table A on the rear fold-out for the default input assignment settings.*

#### 5.7.1 Thermocouple (THC) Inputs

\* **Note.** Use the correct compensating cable between the THC and the terminals – see Table 5.1.

Automatic Cold Junction Compensation (ACJC) is incorporated by use of CJ sensors wired across the input terminals of I/P1 and I/P3 – see Fig. 5.11.

Alternatively, the CJ sensor can be mounted remotely at the point where the thermocouple cable terminates into copper cable, e.g. where cables enter an instrument panel – see Fig. 5.12.

It is possible to use an external fixed cold (reference) junction, if the instrument is programmed for use with millivolt inputs and the appropriate thermocouple linearizer is selected. This is only possible via the PC Configurator.

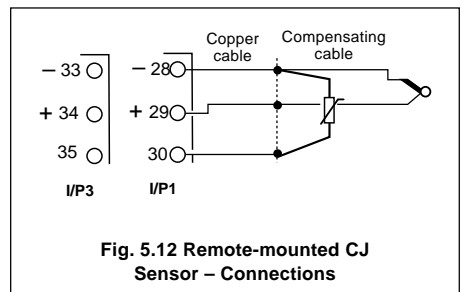
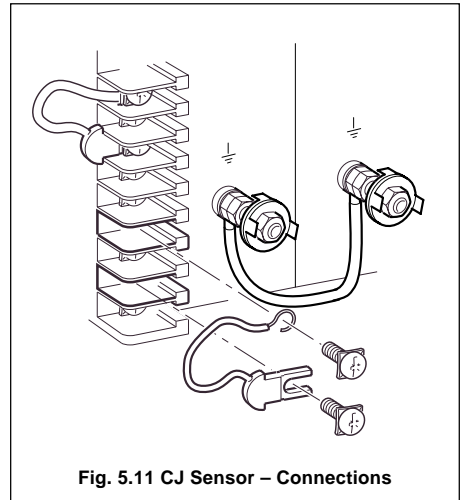



### 5.7.2 3-lead Resistance Thermometer (RTD) Inputs

The three leads must have equal resistance, not exceeding 50Ω each.

### 5.7.3 2-lead Resistance Thermometer (RTD) Inputs

If long leads are necessary it is preferable to use a 3-lead RTD. If the RTD is to be used in a hazardous area, a 3-lead RTD connected via a suitable Zener barrier, must be used.

### 5.8 Output Connections

Make connections as shown in Fig 5.6.

*Refer to Table B on the rear fold-out for the default output assignment settings.*

### 5.9 Power Supply Connections

**Caution.**

- A 1A Type T fuse must be fitted in the live (+ve) supply line.
- The ground line must be connected to the ground studs on the terminal block – see Fig. 5.6.
- Do not disturb the link between the two ground studs.
- The type of power supply required (AC or DC) is stated at the time of order and can be identified from the instrument code number:  
 C35X/XX0X/STD = 100 to 240 V AC  
 C35X/XX1X/STD = 24 V DC

Type of Thermocouple	Compensating Cable											
	BS1843			ANSI MC 96.1			DIN 43714			BS4937 Part No.30		
	+	-	Case	+	-	Case	+	-	Case	+	-	Case
Ni-Cr/Ni-Al (K)	Brown	Blue	Red	Yellow	Red	Yellow	Red	Green	Green	Green	White	Green *
Nicrisil/Nisil (N)	Orange	Blue	Orange	Orange	Red	Orange	—			Pink	White	Pink *
Pt/Pt-Rh (R and S)	White	Blue	Green	Black	Red	Green	Red	White	White	Orange	White	Orange *
Pt-Rh/Pt-Rh (B)	-			-			-			Grey	White	Grey *
Cu/Cu-Ni (T)	White	Blue	Blue	Blue	Red	Blue	Red	Brown	Brown	Brown	White	Brown *
Fe/Con (J)	Yellow	Blue	Black	White	Red	Black	Red	Blue	Blue	Black	White	Black *
* Case Blue for intrinsically safe circuits												
Fe/Con (L) (DIN 43710)	-			—			DIN 43710			—		
							Blue/red	Blue	Blue			

**Table 5.1 Thermocouple Compensating Cable**

A1 Single Loop Controller (Templates 1 and 2)

1 **Single Loop Control** provides basic feedback control using three term PID or On/off control. The controller output is calculated from the difference between the process variable and the control set point. The control set point can be a fixed value entered by the user or from a remote source.

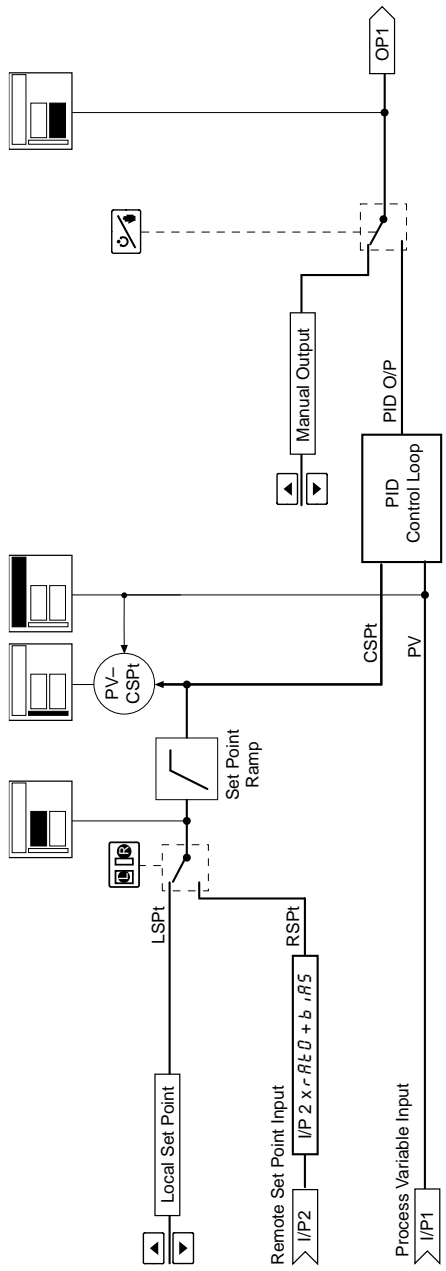

•1

•1 Template 2 Only

## A2 Auto/Manual Station and Analog Backup Station

### A2.1 Series and Parallel Operation

\* **Note.** See Sections A2.2 and A2.3 for detailed templates.

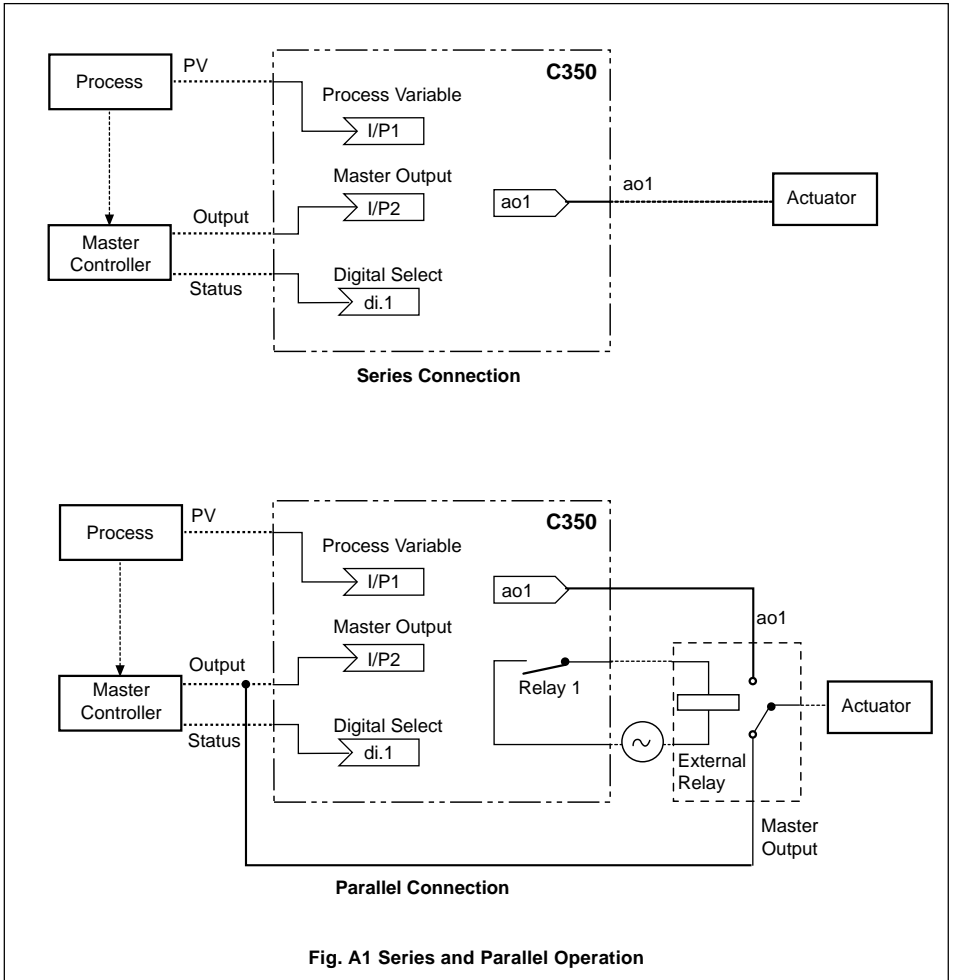



...A2.2 Auto/Manual Station (Templates 3 and 4)

**1** The **Auto/manual Station** provides a backup for a Master controller. In normal operation the COMMANDER 350's current output follows the master controller's output value. A fault in the master system can be identified either by detecting a low signal on the master output (template 3) or via a digital signal (template 4). When a fault is detected the COMMANDER 350 selects manual mode with its output either set to the last valid master output value or to a configured output value – see Section 4.6/ Control Configuration/ Configured Output 1. When the master signal is restored or the digital input returns to its normal state the COMMANDER 350 switches back to auto mode (i.e. COMMANDER 350 output = master output).

The auto/manual station can be used in series or in parallel with the master output signal – see Fig. A1. Parallel operation is achieved by using relay 1 in the COMMANDER 350 to energize an external relay (with suitable changeover contacts for switching low level signals) which selects the output to be routed to the actuator.

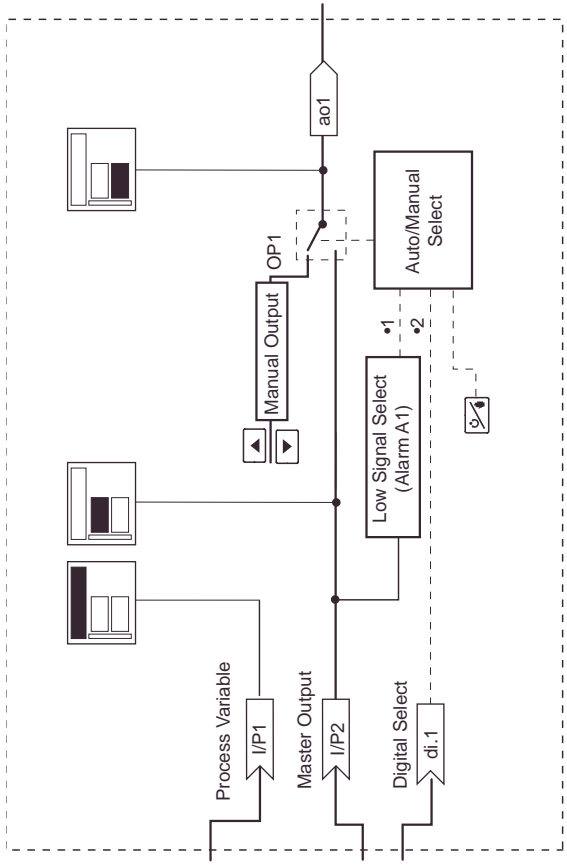

- 1 Template 3 only, Alarm A1 trip value can be set to give the desired low signal detection
- 2 Template 4 only

**A2.3 Analog Backup (Templates 5 and 6)**

**i** The **Analog Backup** provides a backup for a master controller. In normal operation (remote control mode selected) the COMMANDER 350's current output follows the master controller's output value. A fault in the master system can be identified either by detecting a low signal on the master output (template 5) or via a digital signal (template 6). When a fault is detected the COMMANDER 350 switches into local control mode and the process is controlled by the PID output of the COMMANDER 350. The COMMANDER 350 PID algorithm continually tracks the master output value to ensure bumpless transfer from remote to local mode operation. When the master signal is restored or the digital input returns to its normal state the COMMANDER 350 switches back to remote control mode (i.e. COMMANDER 350 output = master output).

The analog backup station can be used in series or in parallel with the master output signal. (See Fig. A1). Parallel operation is achieved by using relay 1 in the COMMANDER 350 to energize an external relay (with suitable changeover contacts for switching low level signals) which selects the output to be routed to the actuator.

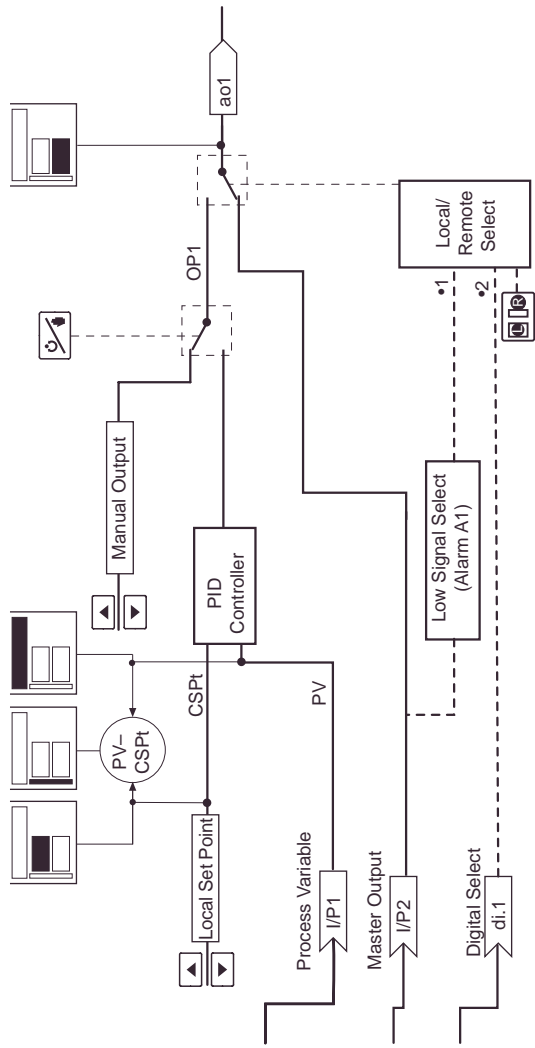

- 1 Template 5 only. Alarm A1 trip value can be set to give the desired low signal detection
- 2 Template 6 only.

**A3 Indicator/Manual Loader Station (Templates 7 and 8)**

**1** The **Indicator/manual Loader Station** is used to display one or two process variables on the digital and bargraph displays. If the control output is assigned to an analog output, the lower display indicates its value which can be adjusted by the user. This output can be used to manually control a process or to provide a set point value for another controller.

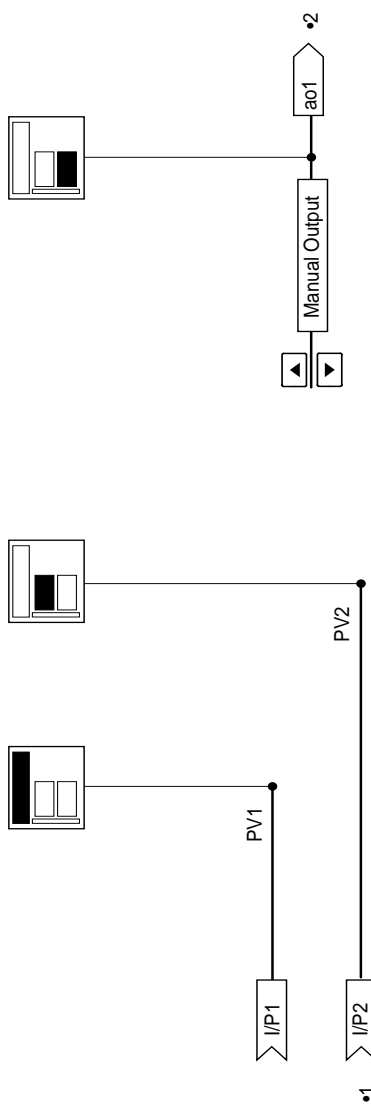

•1 Template 8 Only

•2 Not applicable if Control Output Type is set to 'None' – see Section 4.2/Basic Configuration.

## B1 Introduction

Using the COMMANDER Configurator the COMMANDER 350 can be programmed without using any of the front panel keys.

In addition to the standard settings, the Configurator also gives access to more advanced features not accessible via the front panel keys. These are summarized below.

For information on using individual features, refer to the on-line help facility.

**\*** **Note.** The instrument must be in Configuration Mode (Level 6 or above) and Modbus serial communications must be disabled when uploading or downloading from the PC Configurator.

## B2 Analog Input Customization

- Custom mA, mV, Voltage and Resistance ranges
- Standard Linearizers can be assigned to electrical inputs (eg. allowing transmitter inputs to have thermocouple or resistance linearizers to be applied)
- Programmable fault detection levels (default = 10%)

## B3 Four Programmable Math Blocks

One of seven types can be assigned to each math block:

<b>Standard Arithmetic</b>	Up to 4 operands and 3 operators can be combined in each block, with the operands being calculated sequentially.  Operators: add, subtract, divide, multiply, high select, low select, median select  Operands: any analog or digital signals (digital signals have the value '1' or '0')
<b>Average</b>	The average value of an analog signal over a selectable time period, reset by digital signal
<b>Maximum detection</b>	The maximum value of an analog signal, reset by digital signal
<b>Minimum detection</b>	The minimum value of an analog signal, reset by digital signal
<b>Relative humidity</b>	Calculated from wet and dry bulb temperature sensors
<b>Square root</b>	The square root value of any analog signal
<b>Input multiplexer</b>	Selection of one or two analog variables using a digital signal

## B4 Six Logic Equations

<b>Elements</b>	Up to 15 per equation
<b>Operators</b>	Up to 7 per equation: OR, AND, NOR, NAND, NOT, EXOR
<b>Operands</b>	Up to 8 per equation: any digital signal. The NOT operator can be used to invert digital signals.

## B5 Process Alarm Customization

- Time Hysteresis, 0 to 9999 seconds
- Alarm Disable Source

## B6 Two Real Time Alarms

- Programmable ON days, hours, minutes and duration (00:00 to 23:59)
- Wildcard (\*) to allow operation every x minutes past the hour



### B7 Two Delay Timers

- Programmable delay and duration (0 to 9999 seconds)

### B8 Two Custom Linearizers

- 15 breakpoints per linearizer
- The source can be any analog signal

### B9 Template Customization

Each template can be customized by changing the sources for various functions in the COMMANDER 350. This allows maths blocks and custom linearizers to be added into the standard template format.

The following sources can be programmed:

- process variable inputs
- set point inputs
- position feedback input
- input to ratio/bias block
- ratio inputs
- bias inputs

### B10 Connecting the COMMANDER PC Configurator

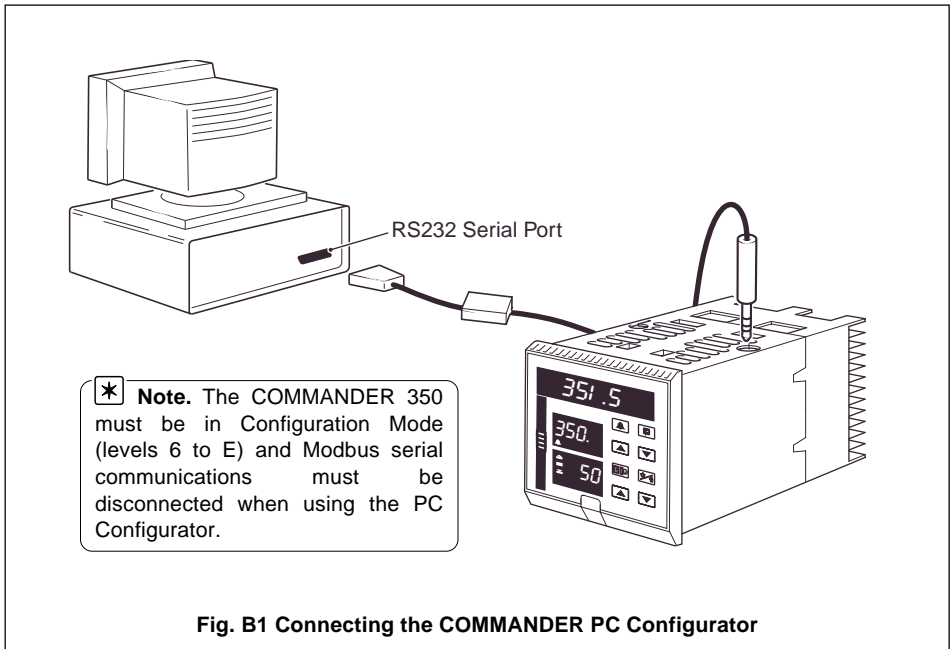

Fig. B1 Connecting the COMMANDER PC Configurator

# SPECIFICATION

## Summary

- 8 application templates: Single loop, Auto/Manual, Analog backup, Indicator
- Two Autotune options
- Control Efficiency Monitor (CEM)
- PC configuration
- IP66/NEMA4X front face

## Operation

### Display

- 1 x 4-digit, 14 mm (Red) LED – process variable
- 1 x 4-digit 8 mm (Green) LED – set point
- 1 x 3-digit, 8 mm (Yellow) LED – output
- 1 x 21-segment deviation bargraph

### Configuration

- Basic configuration via front panel keys or PC
- Advanced feature configuration by PC

### Security

- Password-protected menus

## Standard Functions

### Control Strategies

Single-loop, Auto/manual Station, Analog Backup, Indicator/Manual Loader

### Output Types

Current proportioning, Time proportioning, On/off, Motorized valve (with and without feedback), Heat/cool.

### Control Parameters

Four sets of PI settings, selectable via digital signals

### Set Points

Local, remote and four local fixed set points, selectable via digital signals

### Configured Outputs

Three preset output values, selectable via digital signals

### Autotune

On demand for 1/4 wave or minimal overshoot

### Process Alarms

- Number 8
- Types High/low process,  
High/low output,  
High/low deviation
- Hysteresis Level and time \*
- Alarm enable/disable Enable/disable of alarms via digital signal

### Real Time Alarms \*

- Number 2
- Programmable On time/day and duration

\* Accessed via PC Configurator

**Analog Inputs**

**Universal Process Inputs**

**Number**

2 standard

**Type**

- Universally configurable to provide:
  - Thermocouple (THC)
  - Resistance thermometer (RTD)
  - mV
  - Volts
  - mA
  - Resistance

**Non-universal Process Input**

**Number**

1 standard

**Types**

- mV only (THC only if I/P1 is also THC)
- mA

**Analog Inputs – Common**

**Linearizer Functions**

THC types B, E, J, K, L, N, R, S, T, PT100,  $\sqrt{1}$ ,  $\sqrt[3]{2}$ ,  $\sqrt[5]{2}$

**Input Impedance**

- mA 100 $\Omega$
- mV, V 10M $\Omega$

**Broken Sensor Protection**

Programmable for upscale or downscale drive

**Sample Interval**

125ms (1 input)

**Digital filter**

Programmable

**Cold Junction Compensation**

- Automatic CJC incorporated as standard
- Stability 0.05°C/°C (0.05°F/°F) change in ambient temperature

**Input Protection**

- Common mode rejection >120dB at 50/60Hz with 300 $\Omega$  imbalance resistance
- Series mode rejection > 60dB at 50/60Hz

**Transmitter Power Supply**

- Voltage: 24V DC nominal
- Drive: Up to 60mA, (3 loops)

**Standard Analog Input Ranges**

Thermocouple	Maximum Range °C	Maximum Range °F	Accuracy (% of reading)
B	-18 to 1800	0 to 3270	0.1% or $\pm 1^\circ\text{C}$ (1.8°F) [above 200°C (392°F)] *
E	-100 to 900	-140 to 1650	0.1% or $\pm 0.5^\circ\text{C}$ (0.9°F)
J	-100 to 900	-140 to 1650	0.1% or $\pm 0.5^\circ\text{C}$ (0.9°F)
K	-100 to 1300	-140 to 2350	0.1% or $\pm 0.5^\circ\text{C}$ (0.9°F)
L	-100 to 900	-140 to 1650	0.1% or $\pm 1.5^\circ\text{C}$ (2.7°F)
N	-200 to 1300	-325 to 2350	0.1% or $\pm 0.5^\circ\text{C}$ (0.9°F)
R	-18 to 1700	0 to 3000	0.1% or $\pm 0.5^\circ\text{C}$ (0.9°F) [above 300°C (540°F)] *
S	-18 to 1700	0 to 3000	0.1% or $\pm 0.5^\circ\text{C}$ (0.9°F) [above 200°C(392°F)] *
T	-250 to 300	-400 to 550	0.1% or $\pm 0.5^\circ\text{C}$ (0.9°F)

\* Performance accuracy is not guaranteed below 300°C (572°F) for B, R and S thermocouples  
 Min. span below zero Type T 70°C (126°F) Type N 105°C (189°F)  
 THC standards DIN 43710 IEC 584

RTD	Maximum Range °C	Maximum Range °F	Accuracy (% of reading)**
PT100	-200 to 600	-325 to 1100	0.1% or $\pm 0.5^\circ\text{C}$ (0.9°F)

\*\* RTD, 3-wire platinum, 100 $\Omega$  per DIN43760 standard (IEC751), with range of 0 to 4000 $\Omega$ s

Linear Inputs	Range	Accuracy (% of reading)
Millivolts	0 to 500 mV	0.1% or $\pm 10\mu\text{A}$
Milliamps	0 to 50 mA	0.2% or $\pm 2\mu\text{A}$
Volts	0 to 5V	0.2% or $\pm 2\text{mV}$
Resistance	0 to 5000 $\Omega$	0.2% or $\pm 0.08\Omega$

# ...SPECIFICATION

---

## Outputs

### Control/Retransmission Outputs

Number	2 standard
Type	1 x programmable as analog or logic (digital) output 1 x analog only
Isolation	Galvanically isolated from the rest of the circuitry
Analog range	0 and 20mA (programmable), max. 750Ω accuracy: 0.25%
Digital voltage	17V @ 20mA

### Relay Outputs

Number	2 standard,
Type	SPCO, rated 5A at 115/230V AC

---

### Digital Inputs

Number	2 standard,
Type	Volt-free
Minimum pulse	200ms

---

## Advanced Features

### Maths Blocks \*

Number	4
Operators	+, -, x, /, Average, Maximum, Minimum, High select, Low select, √, Median select, Relative Humidity Input multiplexer (digitally selected)

### Delay Timers \*

Number	2
Programmable	Delay and Duration in seconds

### Logic Equations \*

Number	6
Elements	15 per equation
Operators	OR, AND, NOR, NAND, NOT, EXOR

### Custom Linearizers \*

Number	2
Breakpoints	15 per linearizer

\* Accessed via PC Configurator

## Options

### Relay Outputs

Number	2
Type	SPST, rated 5A at 115/230V AC

### Digital Inputs

Number	2
Type	Volt-free
Minimum pulse	200ms

### Serial Communications

Connections	RS485, 2- or 4-wire
Protocol	Modbus RTU
Isolation	Galvanically isolated from the rest of the circuitry

---

## EMC

### Emissions

Meets requirements of EN50081-2

### Immunity

Meets requirements of EN50082-2

### Design & manufacturing standards

CSA General Safety	Pending
UL General Safety	Pending
FM General Safety	Pending

**Physical****Size**

96 x 96 x 122.5mm (3.78 in. x 3.78 in. x 4.82 in.)

**Weight**

680g (1.5lb)

**Electrical****Voltage**

85 min. to 265 V max. AC 50/60Hz

24V DC

**Power consumption**

15VA max.

**Power interruption protection**

Up to 60ms

**Safety**

General safety EN 61010-1

**Isolation**

All inputs/outputs to earth: 500V DC

Analog/digital output 1  
to rest of the circuitry: 500V DC for 1 minute

Analog output 2 to  
rest of the circuitry: 500V DC for 1 minute

Serial communications  
to rest of the circuitry: 500V DC for 1 minute

**Environmental****Operating Limits**

0°C to 55°C (32°F to 130°F)

5 to 95%RH (non-condensing)

**Temperature stability**

<0.02%/°C or 2 $\mu$ V/°C (<0.011%/°F or 1.1 $\mu$ V/°F)

Long term drift <0.02% of reading or 20 $\mu$ V annually

**Front face**

NEMA4X (IP66)

SS/C351\_5

**Set Up Frames**

<i>Frame Title</i>	<i>Mnemonic</i>	<i>Number</i>
<b>A</b>		
Alarm 1 Trip	<i>1xxx</i>	<i>4.01</i>
Alarm 2 Trip	<i>2xxx</i>	<i>4.02</i>
Alarm 3 Trip	<i>3xxx</i>	<i>4.03</i>
Alarm 4 Trip	<i>4xxx</i>	<i>4.04</i>
Alarm 5 Trip	<i>5xxx</i>	<i>4.05</i>
Alarm 6 Trip	<i>6xxx</i>	<i>4.06</i>
Alarm 7 Trip	<i>7xxx</i>	<i>4.07</i>
Alarm 8 Trip	<i>8xxx</i>	<i>4.08</i>
Approach Band 1	<i>Ab 1</i>	<i>2.15</i>

<b>C</b>		
Control Zone Deadband	<i>dbnd</i>	<i>2.21</i>
Cycle Time 1	<i>[YC 1</i>	<i>2.01</i>
Cycle Time 2	<i>[YC 2</i>	<i>2.02</i>

<b>D</b>		
Deadband (Feedback only)	<i>dbnd</i>	<i>5.03</i>
Derivative Action Time 1	<i>dr U. 1</i>	<i>2.13</i>

<b>H</b>		
Heat/Cool Output 1 Start	<i>Y 1St</i>	<i>2.22</i>
Heat/Cool Output 2 Start	<i>Y 2St</i>	<i>2.23</i>

<b>I</b>		
Integral Action Time 1	<i>IRt. 1</i>	<i>2.09</i>
Integral Action Time 2	<i>IRt. 2</i>	<i>2.10</i>
Integral Action Time 3	<i>IRt. 3</i>	<i>2.11</i>
Integral Action Time 4	<i>IRt. 4</i>	<i>2.12</i>

<b>L</b>		
Local Set Point 1	<i>LSP. 1</i>	<i>3.01</i>
Local Set Point 2	<i>LSP. 2</i>	<i>3.02</i>
Local Set Point 3	<i>LSP. 3</i>	<i>3.03</i>
Local Set Point 4	<i>LSP. 4</i>	<i>3.04</i>

<b>M</b>		
Manual Reset	<i>rSt. 1</i>	<i>2.17</i>
Motorised Valve Bias	<i>Ub 1R</i>	<i>5.02</i>
Motorised Valve Ratio	<i>Ur Rt</i>	<i>5.01</i>

<b>O</b>		
Output 1 On/off Hysteresis Value	<i>HYS. 1</i>	<i>2.03</i>
Output 2 On/off Hysteresis Value	<i>HYS. 2</i>	<i>2.04</i>

<i>Frame Title</i>	<i>Mnemonic</i>	<i>Number</i>
<b>P</b>		
Proportional Band 1	<i>Pb - 1</i>	<i>2.05</i>
Proportional Band 2	<i>Pb - 2</i>	<i>2.06</i>
Proportional Band 3	<i>Pb - 3</i>	<i>2.07</i>
Proportional Band 4	<i>Pb - 4</i>	<i>2.08</i>

<b>R</b>		
Ramp Rate	<i>r-r tE</i>	<i>3.10</i>
Regulator Travel Time	<i>r.t-r U.</i>	<i>5.04</i>
Remote Set Point Bias	<i>b 1RS</i>	<i>3.07</i>
Remote Set Point Ratio	<i>r-Rt 0</i>	<i>3.06</i>

<b>S</b>		
Set Points	<i>LEU3</i>	<i>3.00</i>

<b>T</b>		
Tune	<i>LEU2</i>	<i>2.00</i>

<b>V</b>		
Valve Set Up	<i>LEU5</i>	<i>5.00</i>

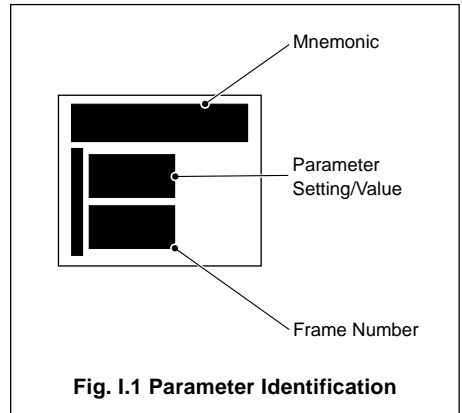

**Fig. I.1 Parameter Identification**

## Configuration Frames

<i>Frame Title</i>	<i>Mnemonic</i>	<i>Number</i>	<i>Frame Title</i>	<i>Mnemonic</i>	<i>Number</i>
<b>A</b>			<b>B</b>		
Alarm 1 Hysteresis	<i>HY5.1</i>	<i>8.03</i>	Basic Configuration	<i>LEUE, APPL</i>	<i>6.00</i>
Alarm 1 Trip	<i>t-r-P.1</i>	<i>8.02</i>	Bias Display Enable	<i>bd.15</i>	<i>b.06</i>
Alarm 1 Type	<i>tYP.1</i>	<i>8.01</i>	Bargraph Increment	<i>b.1nC</i>	<i>b.16</i>
Alarm 2 Hysteresis	<i>HY5.2</i>	<i>8.06</i>	<b>C</b>		
Alarm 2 Trip	<i>t-r-P.2</i>	<i>8.05</i>	Calibration	<i>LEUE, CAL</i>	<i>E.00</i>
Alarm 2 Type	<i>tYP.2</i>	<i>8.04</i>	CJ Beta Value	<i>bEtR</i>	<i>E.14</i>
Alarm 3 Hysteresis	<i>HY5.3</i>	<i>8.09</i>	CJ Reading - I/P1 & I/P2	<i>CJ.1</i>	<i>E.15</i>
Alarm 3 Trip	<i>t-r-P.3</i>	<i>8.08</i>	CJ Reading - I/P3	<i>CJ.3</i>	<i>E.16</i>
Alarm 3 Type	<i>tYP.3</i>	<i>8.07</i>	CJ Reference Value	<i>rEF</i>	<i>E.13</i>
Alarm 4 Hysteresis	<i>HY5.4</i>	<i>8.12</i>	Configuration Password	<i>CPAS</i>	<i>b.09</i>
Alarm 4 Trip	<i>t-r-P.4</i>	<i>8.11</i>	Configured Output 1	<i>COP.1</i>	<i>R.13</i>
Alarm 4 Type	<i>tYP.4</i>	<i>8.10</i>	Configured Output 2	<i>COP.2</i>	<i>R.15</i>
Alarm 5 Hysteresis	<i>HY5.5</i>	<i>8.15</i>	Configured Output 3	<i>COP.3</i>	<i>R.17</i>
Alarm 5 Trip	<i>t-r-P.5</i>	<i>8.14</i>	Control Action	<i>CACt</i>	<i>6.03</i>
Alarm 5 Type	<i>tYP.5</i>	<i>8.13</i>	Control Configuration	<i>LEUR</i>	<i>R.00</i>
Alarm 6 Hysteresis	<i>HY5.6</i>	<i>8.18</i>	Current Time	<i>tCLP</i>	<i>b.15</i>
Alarm 6 Trip	<i>t-r-P.6</i>	<i>8.17</i>	<b>D</b>		
Alarm 6 Type	<i>tYP.6</i>	<i>8.16</i>	Day Setting	<i>dRY</i>	<i>b.10</i>
Alarm 7 Hysteresis	<i>HY5.7</i>	<i>8.21</i>	Digital Output 1 Polarity	<i>dG.1P</i>	<i>C.08</i>
Alarm 7 Trip	<i>t-r-P.7</i>	<i>8.20</i>	Digital Output 1 Source	<i>dG.1R</i>	<i>C.07</i>
Alarm 7 Type	<i>tYP.7</i>	<i>8.19</i>	<b>F</b>		
Alarm 8 Hysteresis	<i>HY5.8</i>	<i>8.24</i>	Feedback Range High	<i>Fb.H.1</i>	<i>E.12</i>
Alarm 8 Trip	<i>t-r-P.8</i>	<i>8.23</i>	Feedback Range Low	<i>Fb.L.0</i>	<i>E.11</i>
Alarm 8 Type	<i>tYP.8</i>	<i>8.22</i>	<b>G</b>		
Alarm Acknowledge Enable	<i>FPAK</i>	<i>b.03</i>	Global Alarm Acknowledge	<i>GACK</i>	<i>8.25</i>
Alarm Configuration	<i>LEUE, AL.5</i>	<i>8.00</i>	<b>H</b>		
Analog I/P 1 Offset Cal	<i>OFF.1</i>	<i>E.01</i>	Hour Setting	<i>HOUR</i>	<i>b.13</i>
Analog I/P 1 Span Cal	<i>SPN.1</i>	<i>E.02</i>			
Analog I/P 2 Offset Cal	<i>OFF.2</i>	<i>E.03</i>			
Analog I/P 2 Span Cal	<i>SPN.2</i>	<i>E.04</i>			
Analog I/P 3 Offset Cal	<i>OFF.3</i>	<i>E.05</i>			
Analog I/P 3 Span Cal	<i>SPN.3</i>	<i>E.06</i>			
Analog O/P 1 Electrical High	<i>AN.1H</i>	<i>C.03</i>			
Analog O/P 1 Electrical Low	<i>AN.1L</i>	<i>C.04</i>			
Analog O/P 1 Engineering High	<i>r.1H</i>	<i>C.05</i>			
Analog O/P 1 Engineering Low	<i>r.1L</i>	<i>C.06</i>			
Analog O/P 2 Electrical High	<i>AN.2H</i>	<i>C.11</i>			
Analog O/P 2 Electrical Low	<i>AN.2L</i>	<i>C.12</i>			
Analog O/P 2 Engineering High	<i>r.2H</i>	<i>C.13</i>			
Analog O/P 2 Engineering Low	<i>r.2L</i>	<i>C.14</i>			
Analog Output 1 Source	<i>AN.1R</i>	<i>C.02</i>			
Analog Output 2 Source	<i>AN.2R</i>	<i>C.10</i>			
Analog/Dig Output 1 Type	<i>tYP.1</i>	<i>C.01</i>			
Auto Selection Source	<i>ASrC</i>	<i>R.18</i>			
Auto/Manual Switch Enable	<i>FPA.</i>	<i>b.01</i>			
Autotune Password	<i>APAS</i>	<i>b.07</i>			

## ...FRAMES INDEX

### ...Configuration Frames

<i>Frame Title</i>	<i>Mnemonic</i>	<i>Number</i>	<i>Frame Title</i>	<i>Mnemonic</i>	<i>Number</i>
<b>I</b>					
Input 1 Broken Sensor	<i>b5d.1</i>	<i>7.06</i>	Power Fail Recovery Mode	<i>P_rEC</i>	<i>R.01</i>
Input 1 Decimal Point	<i>dP.1</i>	<i>7.03</i>	Power Fail Recovery Time	<i>rECt</i>	<i>R.02</i>
Input 1 Engineering High	<i>EN1H</i>	<i>7.04</i>	Process Variable Fail Action	<i>P_UFA</i>	<i>R.03</i>
Input 1 Engineering Low	<i>EN1L</i>	<i>7.05</i>	PV Fail Default Output	<i>dF.OP</i>	<i>R.04</i>
Input 1 Filter Time Constant	<i>FLt.1</i>	<i>7.07</i>	<b>R</b>		
Input 1 Temp Units	<i>UNt.1</i>	<i>7.02</i>	Ratio Display Enable	<i>r.d15</i>	<i>b.05</i>
Input 1 Type	<i>tYP.1</i>	<i>7.01</i>	Regulator Travel Time	<i>r.t.r.U.</i>	<i>E.08</i>
<b>Input 2</b>					
Input 2 Broken Sensor	<i>b5d.2</i>	<i>7.13</i>	Relay 1 Polarity	<i>r.L1P</i>	<i>C.18</i>
Input 2 Decimal Point	<i>dP.2</i>	<i>7.10</i>	Relay 1 Source	<i>r.L1R</i>	<i>C.17</i>
Input 2 Engineering High	<i>EN2H</i>	<i>7.11</i>	Relay 2 Polarity	<i>r.L2P</i>	<i>C.20</i>
Input 2 Engineering Low	<i>EN2L</i>	<i>7.12</i>	Relay 2 Source	<i>r.L2R</i>	<i>C.19</i>
Input 2 Filter Time Constant	<i>FLt.2</i>	<i>7.14</i>	<b>Relay 3</b>		
Input 2 Temp Units	<i>UNt.2</i>	<i>7.09</i>	Relay 3 Polarity	<i>r.L3P</i>	<i>C.22</i>
Input 2 Type	<i>tYP.2</i>	<i>7.08</i>	Relay 3 Source	<i>r.L3R</i>	<i>C.21</i>
<b>Input 3</b>					
Input 3 Broken Sensor	<i>b5d.3</i>	<i>7.20</i>	Relay 4 Polarity	<i>r.L4P</i>	<i>C.24</i>
Input 3 Decimal Point	<i>dP.3</i>	<i>7.17</i>	Relay 4 Source	<i>r.L4R</i>	<i>C.23</i>
Input 3 Engineering High	<i>EN3H</i>	<i>7.18</i>	Remote Set Point Source	<i>r.SrC</i>	<i>9.14</i>
Input 3 Engineering Low	<i>EN3L</i>	<i>7.19</i>	RSPT Fault Action	<i>S.P.FA</i>	<i>9.06</i>
Input 3 Filter Time Constant	<i>FLt.3</i>	<i>7.21</i>	<b>S</b>		
Input 3 Temp Units	<i>UNt.3</i>	<i>7.16</i>	Serial Communications	<i>LEUd</i>	<i>d.00</i>
Input 3 Type	<i>tYP.3</i>	<i>7.15</i>	Serial Configuration	<i>S.C.FG</i>	<i>d.01</i>
<b>L</b>					
Level Heading	<i>LEU7</i>	<i>7.00</i>	Set Point Configuration	<i>LEU9, SEtP</i>	<i>9.00</i>
Local Set Point Source	<i>L.C.Sr</i>	<i>9.13</i>	Set Point 1 Source	<i>L.Sr.1</i>	<i>9.08</i>
Local/Remote Enable	<i>FPLr</i>	<i>b.02</i>	Set Point 2 Source	<i>L.Sr.2</i>	<i>9.09</i>
Local/Remote Set Point Source	<i>L.r.Sr</i>	<i>9.12</i>	Set Point 3 Source	<i>L.Sr.3</i>	<i>9.10</i>
<b>M</b>					
MV Calibration selection	<i>FCRL</i>	<i>E.07</i>	Set Point 4 Source	<i>L.Sr.4</i>	<i>9.11</i>
MV Feedback – closed	<i>CCRL</i>	<i>E.09</i>	Set Point Default Value	<i>dF.SP</i>	<i>9.07</i>
MV Feedback – open	<i>OCRL</i>	<i>E.10</i>	Set Point High Limit	<i>S.P.t.H</i>	<i>9.02</i>
Mains Rejection	<i>F.r.EJ</i>	<i>6.06</i>	Set Point Low Limit	<i>S.P.t.L</i>	<i>9.03</i>
Man/Auto Selection Source	<i>A..Sr</i>	<i>R.16</i>	Set Point Tracking	<i>t.r.CY.</i>	<i>9.01</i>
Manual 1 Selection Source	<i>..Sr.1</i>	<i>R.12</i>	Set up Password	<i>S.P.A5</i>	<i>b.10</i>
Manual 2 Selection Source	<i>..Sr.2</i>	<i>R.14</i>	Slave Set Point High Limit	<i>S.S.P.H</i>	<i>9.04</i>
Minute Setting	<i>.1n</i>	<i>b.14</i>	Slave Set Point Low Limit	<i>S.S.P.L</i>	<i>9.05</i>
<b>Modbus</b>					
Modbus Address	<i>Rddr</i>	<i>d.03</i>	Set Point Adjust Disable	<i>S.A.dJ</i>	<i>b.04</i>
Modbus Parity	<i>P.r.tY</i>	<i>d.02</i>	<b>T</b>		
<b>O</b>					
O/P Low Limit	<i>OP.L0</i>	<i>R.06</i>	Template Applications	<i>t.APP</i>	<i>6.01</i>
O/P High Limit	<i>OP.H1</i>	<i>R.05</i>	Time Display	<i>t.C.L.P.</i>	<i>b.13</i>
OP 1 High Limit	<i>OP.1H</i>	<i>R.07</i>	Tune Select Source 1	<i>t.15r</i>	<i>R.19</i>
OP 2 High Limit	<i>OP.2H</i>	<i>R.08</i>	Tune Select Source 2	<i>t.25r</i>	<i>R.20</i>
OP 2 Low Limit	<i>OP.2L</i>	<i>R.09</i>	Tune Select Source 3	<i>t.35r</i>	<i>R.21</i>
Operator Configuration	<i>LEUb, OPEr</i>	<i>b.00</i>	Tune Select Source 4	<i>t.45r</i>	<i>R.22</i>
<b>Output</b>					
Output Assignment	<i>LEUC, R55n</i>	<i>C.00</i>			
Output Slew Rate	<i>OP.Sr</i>	<i>R.10</i>			
Output Slew Rate Disable	<i>Sr.d5</i>	<i>R.11</i>			
Output Type	<i>OLYP</i>	<i>6.02</i>			



# INDEX

<b>A</b>		<b>...C</b>	
Accessories .....	1	Configuration Error .....	9
Alarms .....	34, 47	Configuration Password .....	60
Acknowledge .....	5, 50	Configured Outputs 1 to 3 .....	57
Acknowledge enable .....	59	See Also: Auto/Manual and Backup Templates	
Configuration .....	47	Control Action .....	42
Global .....	50	Control Configuration – Level A .....	54
Hysteresis .....	49, 50	Control Efficiency Monitor .....	24
Set Up .....	34	Control Set Point – see Set Points	
Trip Settings .....	34, 47	Control Output Deadband .....	31
Type .....	34, 49	Custom Linearizer .....	87
Analog Backup Station .....	16, 84	<b>D</b>	
Analog Inputs – Level 7 .....	43	Date and Time Setting .....	60
Broken Sensor .....	44, 45, 46	Deadband	
Decimal Point .....	43, 45, 46	Control Output .....	31
Engineering Range .....	44, 45, 46	MV Feedback .....	35
Calibration .....	68	Default Outputs .....	52, 55, 57
Failure Action .....	55	Delay Timer .....	87
Analog Outputs 1 and 2 .....	61	Derivative Action Time .....	30
See Also: Digital Outputs 1 and 2		Deviation Alarms .....	47
Electrical Ranges .....	62, 64	Digital Inputs 1 to 4 .....	76, 77
Engineering Ranges .....	62, 64	See Also: Rear Fold-out/ Table C	
Sources .....	62, 64	Digital Outputs 1 and 2 .....	61
See Also: Rear Fold-out/ Table D		Polarity .....	61, 63
Analog Sources .....	Rear Fold-out/ Table D	Source .....	61, 63
Approach Band .....	30	Digital Sources .....	Rear Fold-out/ Table C
Auto-tune .....	21	Direct Control Action .....	42
Error .....	21	Displays .....	8, 9, 11
Password .....	60	LCD Alphabet .....	8
Starting .....	23	<b>E</b>	
Auto/Manual		Electrical Connections .....	76
Mode Selection Source .....	56, 57, 58	Error Codes .....	9
A/M Station Template .....	14, 74	<b>F</b>	
A/M Switch .....	4, 50	Failure Modes	
<b>B</b>		Analog Input .....	55
Bargraph .....	3	Power Failure .....	54
Increment .....	60	Process Variable .....	55
See Also: Relevant Operator		Remote Set Point .....	52
Template in Section 2		Fault-finding – see Error Messages	
Basic Configuration – Level 6 .....	39	Fault Detection Level .....	86
Boundless Control – see Motorized Valves		Feedback (Motorized Valves) .....	35
Broken Sensor Drive .....	44, 45, 46	See Also: Analog Inputs (Process Variable)	
<b>C</b>		Filter Time Constant .....	44, 45, 46
Calibration – see Analog Inputs		Fine Tuning .....	25, 68
Calibration Error .....	9	<b>G</b>	
Character Set .....	8	Gain Scheduling	
Clock Settings .....	60	Selection .....	58
Cold Junction		Sources .....	58
Compensation .....	70, 77, 80	Proportional and Integral Terms .....	29
Failed .....	9	Global Alarm Acknowledge Source .....	50
		Glossary of Abbreviations .....	10

**H**

Heat/Cool .....	19
Control Action .....	40, 42
Output limits .....	55
Start positions .....	31
Hysteresis	
Alarms .....	47 to 50
On/off Control .....	28

**I**

Inputs – see Analog Inputs	
Installation .....	71
Integral Action Time .....	29

**K**

Klaxon Alarms .....	47
---------------------	----

**L**

Latch Alarms .....	48
LEDs .....	8
Linearizers .....	43, 45, 46, 86
Line Filter Frequency .....	42
Local Set Point – see Set Points	
Local/Remote Key Enable .....	59
Local/Remote Mode Selection .....	6, 16, 52, 53
Locking Front Panel Keys .....	59
Logic Equations .....	86
Loop Break Monitor .....	10

**M**

Mains Rejection Frequency .....	42
Manual Mode Selection .....	56, 57, 59
Pre-set manual output .....	57
Manual Reset .....	30
Maths Blocks .....	86
Mechanical Installation .....	71
MODBUS .....	67, 76
Mounting .....	72
Motorized Valve	
Boundless .....	36
Calibration .....	69
Connections .....	79
Control Type Selection .....	40
Feedback .....	35
Regulator Travel Time .....	35, 37, 69
Set Up .....	35

**O**

On/Off Control .....	28
See Also: Control Types	
Operator Configuration – Level B .....	59
Operating Displays .....	3
Operator Ratio/Bias Display Enable .....	59
Operator Level .....	11

**...O**

Output	
Assignment – Level C .....	61
Connections .....	76, 78, 79
Heat/Cool .....	19
Limits .....	55
Slew Rate .....	56
Output Sources	
Types .....	40
Option Board .....	76

**P**

Panel Clamps .....	2, 73
PC Configurator .....	86
PID Parameters .....	29, 30
See Also: Gain Scheduling	
Power Fail Recovery .....	54
Power Supplies .....	76, 80
Power Up Displays .....	11
Process	
Alarms .....	48
Labels .....	75
Optimization – see Control Efficiency Monitor	
Variable – see Analog Inputs	
Proportional Band Settings .....	29, 30

**R**

Ramp Rate (Set Point) .....	33
See Also: Output Slew Rate	
Ratio	
Ratio Display Enable .....	59
Remote Set Point .....	32
Real-time Alarm .....	86
Reference Tables .....	Rear Fold-out
Relative Humidity .....	86
Regulator Travel Time – see Motorized Valves	
Relay	
Connections .....	76
Links .....	78
See Also: Output Assignment, Output Types	
Remote Set Point	
Failure Action .....	52
Scaling .....	32
Selection Source .....	53
Resistance Thermometer .....	43, 46, 76
Retransmission – See Analog Outputs,	
Analog Sources	
Reverse Control Action .....	42

**S**

Secret-til-Lit Indicators .....	8
Security Options .....	60
Serial Communications – Level d .....	67
Set Points	
Configuration – Level 9 .....	51
Default Value .....	52
Limits .....	51
Operator Adjust enable .....	59
Ramp Rate .....	33
Scaling .....	32
Selecting .....	52
Setting – see Relevant Operator Template	
Sources .....	52
Tracking .....	51
Single Loop	
Controllers .....	12, 16, 81, 84
Siting .....	71
Short-cut keys .....	7
Slew Rate .....	56
Soft-start – see Set Point Ramp Rate, Output Slew Rate	
Span Adjustment – see Calibration	

**T**

Temperature Units .....	43, 45, 46
Template Applications .....	11, 39, 81
Rear Fold-out, Table A	
Terminals and Connections .....	76
Thermocouple .....	43, 44, 45, 46, 76
Time	
Setting .....	60
Real-time alarms .....	86
Delay Timers .....	86
Tuning	
Automatic .....	21
Manual .....	25
Tune Parameter Source .....	58

**U**

Units – see Temperature Units

**V**

Valve – see Motorized Valve	
Valve Sticking .....	9

**W**

Warning Messages .....	9
Watchdog .....	10







# PRODUCTS & CUSTOMER SUPPORT

## Products

### Automation Systems

- **for the following industries:**
  - Chemical & Pharmaceutical
  - Food & Beverage
  - Manufacturing
  - Metals and Minerals
  - Oil, Gas & Petrochemical
  - Pulp and Paper

### Drives and Motors

- **AC and DC Drives, AC and DC Machines, AC motors to 1kV**
- **Drive systems**
- **Force Measurement**
- **Servo Drives**

### Controllers & Recorders

- **Single and Multi-loop Controllers**
- **Circular Chart, Strip Chart and Paperless Recorders**
- **Paperless Recorders**
- **Process Indicators**

### Flexible Automation

- **Industrial Robots and Robot Systems**

### Flow Measurement

- **Electromagnetic Magnetic Flowmeters**
- **Mass Flow Meters**
- **Turbine Flowmeters**
- **Wedge Flow Elements**

### Marine Systems & Turbochargers

- **Electrical Systems**
- **Marine Equipment**
- **Offshore Retrofit and Referbishment**

### Process Analytics

- **Process Gas Analysis**
- **Systems Integration**

### Transmitters

- **Pressure**
- **Temperature**
- **Level**
- **Interface Modules**

### Valves, Actuators and Positioners

- **Control Valves**
- **Actuators**
- **Positioners**

### Water, Gas & Industrial Analytics Instrumentation

- **pH, conductivity, and dissolved oxygen transmitters and sensors**
- **ammonia, nitrate, phosphate, silica, sodium, chloride, fluoride, dissolved oxygen and hydrazine analyzers.**
- **Zirconia oxygen analyzers, katharometers, hydrogen purity and purge-gas monitors, thermal conductivity.**

## Customer Support

We provide a comprehensive after sales service via our Worldwide Service Organization. Contact one of the following offices for details on your nearest Service and Repair Centre.

### United Kingdom

ABB Limited  
Tel: +44 (0)1480 475321  
Fax: +44 (0)1480 217948

### United States of America

ABB Inc.  
Tel: +1 215 674 6000  
Fax: +1 215 674 7183

### Client Warranty

Prior to installation, the equipment referred to in this manual must be stored in a clean, dry environment, in accordance with the Company's published specification. Periodic checks must be made on the equipment's condition.

In the event of a failure under warranty, the following documentation must be provided as substantiation:

1. A listing evidencing process operation and alarm logs at time of failure.
2. Copies of operating and maintenance records relating to the alleged faulty unit.

## REFERENCE TABLES

### Table A – Template Applications

Config. Display	Template Title	Analog Input 1 (I/P1)	Analog Input 2 (I/P2)	Analog Input 3 (I/P3)
1. 5L	Single loop	Process Variable		Feedback †
2. 5L	Single loop + Remote set point	Process Variable	Remote Set Point	Feedback †
3. R <sub>-</sub>	Auto/Manual station (low signal select)	Process Variable	Master Output	–
4. R <sub>-</sub>	Auto/Manual station (digital select)	Process Variable	Master Output	–
5. R <sub>b</sub>	Analog backup (low signal select)	Process Variable	Master Output	–
6. R <sub>b</sub>	Analog backup (digital select)	Process Variable	Master Output	–
7. I <sub>n</sub>	Single indicator/manual loader	Process Variable	–	–
8. I <sub>n</sub>	Double indicator/manual loader	Process Variable 1	Process Variable 2	–

† Motorized Valve output types only

### Table B – Output Sources

\* **Note.** Settings shown in **bold** are fixed and cannot be adjusted. Other settings are changed in Level C/ Output Assignment.

Setting	Output Type	Relays				Analog Outputs		Digital Output
		Rly 1	Rly 2	Rly 3	Rly 4	ao1	ao2	do1
<i>none</i>	None	–	–	–	–	–	–	–
<i>RNLG</i>	Analog Output	Alm1#	Alm 2	Alm 3	Alm 4	<b>OP1</b>	PV	–
<i>rLY</i>	Relay Output	<b>OP1</b>	Alm 1#	Alm 2	Alm 3	PV	CSPT	–
<i>dIG</i>	Digital Output	Alm 1	Alm 2	Alm 3	Alm 4	OP1	PV	<b>OP1</b>
<i>PFb</i>	Motorized valve with FB	<b>OPEN</b>	<b>CLOSE</b>	Alm 1	Alm 2	PV	CSPT	–
<i>bnd</i>	Motorized valve without FB	<b>OPEN</b>	<b>CLOSE</b>	Alm 1	Alm 2	PV	CSPT	–
<i>HCrr</i>	Heat/Cool	<b>OP1</b> (Heat)	<b>OP2</b> (Cool)	Alm 1	Alm 2	PV	CSPT	–
<i>HCrd</i>	Heat/Cool	<b>OP1</b>	Alm 1	Alm 2	Alm 3	–	PV	<b>OP2</b>
<i>HCdr</i>	Heat/Cool	<b>OP2</b>	Alm 1	Alm 2	Alm 3	–	PV	<b>OP1</b>
<i>HCRR</i>	Heat/Cool	<b>OP2</b>	Alm 1	Alm 2	Alm 3	<b>OP1</b>	PV	–
<i>HCRA</i>	Heat/Cool	Alm 1	Alm 2	Alm 3	Alm 4	<b>OP1</b>	<b>OP2</b>	–

# Relay 1 is assigned to energize when in manual mode and templates 3, 4, 5 or 6 are selected

Alm = Alarm  
Rly = Relay  
ao1 = Analog Output1  
ao2 = Analog Output2

do1 = Digital Output 1  
OP1, 2 =Output 1, 2  
PV = Process Variable RTX  
CSPT = Set Point RTX

## REFERENCE TABLES

### Table C – Digital Sources

Source	Display	Description	Source	Display	Description
<b>Control Outputs</b>	<i>OP 1</i>	Control output 1 (heat)	<b>Failure States</b>	<i>F. IN. 1</i>	Input 1 failed
	<i>OP 2</i>	Control output 2 (cool)		<i>F. IN. 2</i>	Input 2 failed
	<i>OPEN</i>	Motorized valve Open Relay		<i>F. IN. 3</i>	Input 3 failed
	<i>CLSE</i>	Motorized valve Close Relay		<i>LbP1</i>	Loop break - analog output 1
<b>Process Alarms</b>	<i>R 1</i>	Alarm 1 active		<i>dDC</i>	Watchdog active
	<i>R 2</i>	Alarm 2 active		<i>PF</i>	Power fail
	:				
	<i>RB</i>	Alarm 8 active	<b>Logic equations*</b>	<i>LG 1</i>	Logic equation 1 true
<b>Alarm Acknowledge</b>	<i>ACK. 1</i>	Alarm 1 acknowledge		<i>LG 2</i>	Logic equation 2 true
	<i>ACK. 2</i>	Alarm 2 acknowledge		:	
	:		<i>LG 5</i>	Logic equation 6 true	
<b>Digital inputs</b>	<i>D.G1</i>	Digital input 1 active	<b>Timers</b>	<i>r-t1</i>	Real time alarm 1
	<i>D.G2</i>	Digital input 2 active		<i>r-t2</i>	Real time alarm 2
	<i>D.G3</i>	Digital input 3 active		<i>d-t1</i>	Delay timer 1
	<i>D.G4</i>	Digital input 4 active		<i>d-t2</i>	Delay timer 2
<b>Control Modes</b>	<i>_RN</i>	Manual mode selected	<b>Modbus Signals</b>	<i>_b.1</i>	Modbus Signal 1
	<i>RUt</i>	Auto mode selected		<i>_b.2</i>	Modbus Signal 2
	<i>LDC</i>	Local set point/ Local control selected		<i>_b.3</i>	Modbus Signal 3
	<i>rE-</i>	Remote set point/ Remote control selected		<i>_b.4</i>	Modbus Signal 4
			<b>Other</b>	<i>ON</i>	Always enabled

\* The default factory settings for each logic equation is:

LG1 – The OR of all alarm states; LG2 – The AND of all alarm states

LG3 – The OR of the alarm acknowledge states

LG4 – The OR of the first four alarm state; LG5 – The OR of the second four alarm states

LG6 – The OR of the input fail states

### Table D – Analog Sources

Display	Description	Display	Description
<i>OP 1</i>	Control output 1 (heat)	<i>SSPt</i>	Slave setpoint
<i>OP 2</i>	Control output 2 (cool)	<i>dEU1</i>	PID deviation (PV – setpoint)
<i>PV1</i>	Process variable 1	<i>AVP</i>	Actual valve position
<i>PV2</i>	Process variable 2	<i>bLP1</i>	Math block 1 output
<i>I/P 1</i>	Analog input 1	<i>bLP2</i>	Math block 2 output
<i>I/P 2</i>	Analog input 2	<i>bLP3</i>	Math block 3 output
<i>I/P 3</i>	Analog input 3	<i>bLP4</i>	Math block 4 output
<i>CSPt</i>	Control setpoint	<i>CU5.1</i>	Custom linearizer 1 output
<i>rSPt</i>	Remote setpoint	<i>CU5.2</i>	Custom linearizer 2 output
<i>LSP 1</i>	Local setpoint 1	<i>PID1</i>	PID block output
<i>LSP 2</i>	Local setpoint 2	<i>r.b.</i>	Remote set point ratio/bias
<i>LSP 3</i>	Local setpoint 3		
<i>LSP 4</i>	Local setpoint 4		

ABB has Sales & Customer Support expertise in over 100 countries worldwide

[www.abb.com](http://www.abb.com)

The Company's policy is one of continuous product improvement and the right is reserved to modify the information contained herein without notice.

Printed in UK (10.03)

© ABB 2003

# ABB

**ABB Limited**  
Howard Road, St. Neots  
Cambridgeshire, PE19 8EU  
UK  
Tel: +44 (0)1480 475 321  
Fax: +44 (0)1480 217 948

**ABB Inc.**  
125 E. County Line Road  
Warminster, PA 18974  
USA  
Tel: +1 215 674 6000  
Fax: +1 215 674 7183