

COMMANDER 310  
Universal  
Process Controller

## Installation Guide



ABB Instrumentation



# ABB INSTRUMENTATION

## The Company

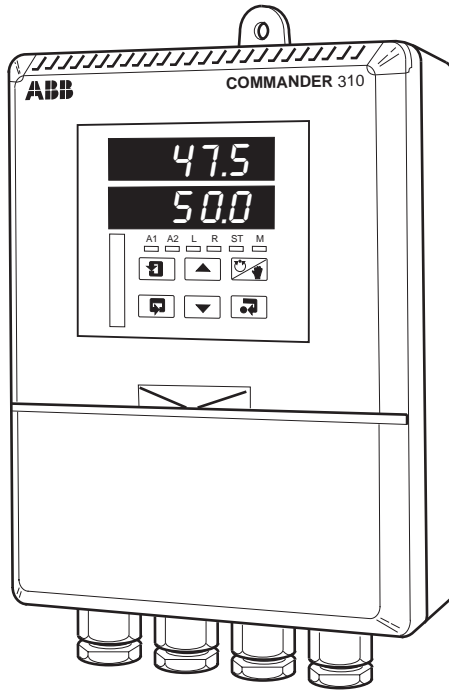
ABB Instrumentation is an established world force in the design and manufacture of instrumentation for industrial process control, flow measurement, gas and liquid analysis and environmental applications.

As a part of ABB, a world leader in process automation technology, we offer customers application expertise, service and support worldwide.

We are committed to teamwork, high quality manufacturing, advanced technology and unrivalled service and support.

The quality, accuracy and performance of the Company's products result from over 100 years experience, combined with a continuous program of innovative design and development to incorporate the latest technology.

The NAMAS Calibration Laboratory No. 0255(B) is just one of the ten flow calibration plants operated by the Company, and is indicative of ABB Instrumentation's dedication to quality and accuracy.

## BS EN ISO 9001



St Neots, U.K. – Cert. No. Q5907

Stonehouse, U.K. – Cert. No. FM 21106

## EN 29001 (ISO 9001)



Lenno, Italy – Cert. No. 9/90A



Stonehouse, U.K. – Cert. No. 0255

## Use of Instructions



### Warning.

An instruction that draws attention to the risk of injury or death.



### Caution.

An instruction that draws attention to the risk of damage to the product, process or surroundings.



### Note.

Clarification of an instruction or additional information.



### Information.

Further reference for more detailed information or technical details.

Although **Warning** hazards are related to personal injury, and **Caution** hazards are associated with equipment or property damage, it must be understood that operation of damaged equipment could, under certain operational conditions, result in degraded process system performance leading to personal injury or death. Therefore, comply fully with all **Warning** and **Caution** notices.

Information in this manual is intended only to assist our customers in the efficient operation of our equipment. Use of this manual for any other purpose is specifically prohibited and its contents are not to be reproduced in full or part without prior approval of Technical Communications Department, ABB Instrumentation.

## Health and Safety

To ensure that our products are safe and without risk to health, the following points must be noted:

1. The relevant sections of these instructions must be read carefully before proceeding.
2. Warning labels on containers and packages must be observed.
3. Installation, operation, maintenance and servicing must only be carried out by suitably trained personnel and in accordance with the information given.
4. Normal safety precautions must be taken to avoid the possibility of an accident occurring when operating in conditions of high pressure and/or temperature.
5. Chemicals must be stored away from heat, protected from temperature extremes and powders kept dry. Normal safe handling procedures must be used.
6. When disposing of chemicals ensure that no two chemicals are mixed.

Safety advice concerning the use of the equipment described in this manual or any relevant hazard data sheets (where applicable) may be obtained from the Company address on the back cover, together with servicing and spares information.

---

# CONTENTS

---

<b>1</b>	<b>INTRODUCTION .....</b>	<b>2</b>
<b>2</b>	<b>PREPARATION .....</b>	<b>3</b>
2.1	Checking the Code Number .....	3
<b>3</b>	<b>MECHANICAL INSTALLATION .....</b>	<b>4</b>
3.1	Siting .....	4
3.2	Mounting .....	5
<b>4</b>	<b>ELECTRICAL INSTALLATION .....</b>	<b>6</b>
4.1	Access to Terminals .....	6
4.2	Setting the Input Selector Links ...	6
4.3	Setting the Isolated Output Link ...	6
4.4	Cable Glands and Conduit Fixings .....	8
4.4.1	Cable Glands (IEC – 20mm) .....	8
4.4.2	Conduit Adaptors (N. American – 0.5in) .....	8
4.4.3	Cable Glands (N. American – 0.5in) .....	9
4.5	Connections Summary .....	10
4.6	Input Connections .....	12
4.6.1	Thermocouple (THC) Inputs .....	12
4.6.2	3-lead Resistance Thermometer (RTD) Inputs .....	12
4.6.3	2-lead Resistance Thermometer (RTD) Inputs .....	12
4.6.4	Links for Unused Inputs ..	12
4.7	Output Connections .....	14
4.8	Relay Connections .....	14
4.9	Motorized Valve Connections ....	14
4.10	Logic Input Connections .....	15
4.11	Power Supply Selection and AC Connections .....	16
<b>5</b>	<b>INSTALLATION RECORD .....</b>	<b>17</b>

# 1 INTRODUCTION

The COMMANDER 310 Series documentation is shown in Fig. 1.1. The **Standard Manuals**, including the specification sheet, are supplied with all instruments. The **Modbus Supplement** is supplied with instruments configured for Modbus Serial Communication.

This manual includes an **Installation Record** which should be completed as a log of the electrical installation. The record is useful when carrying out initial instrument programming and can be retained for future reference.

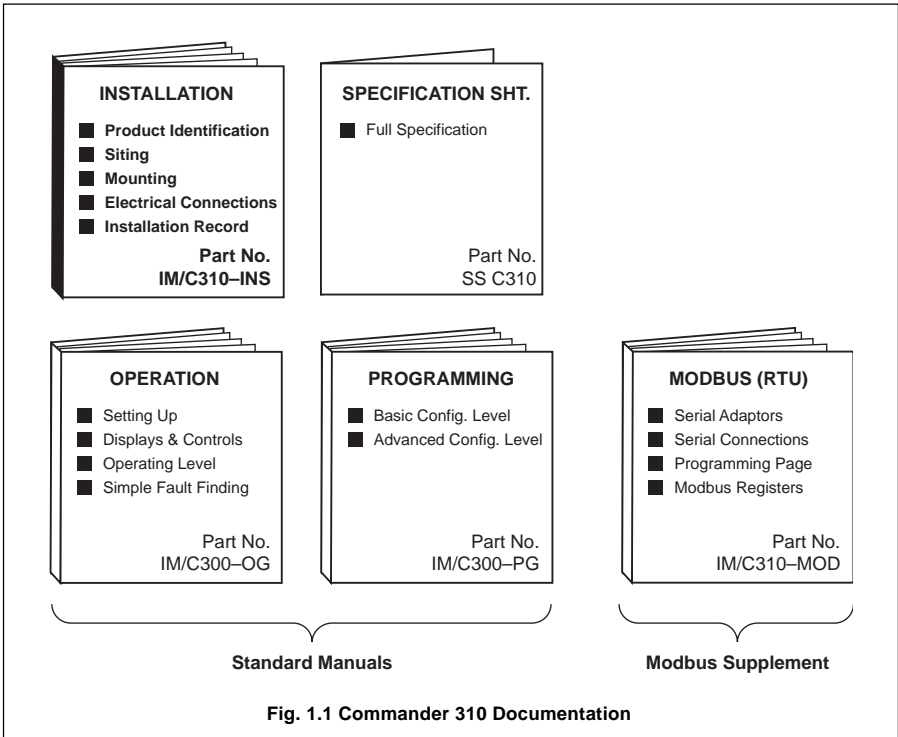

## 2 PREPARATION

### 2.1 Checking the Code Number – Fig. 2.1

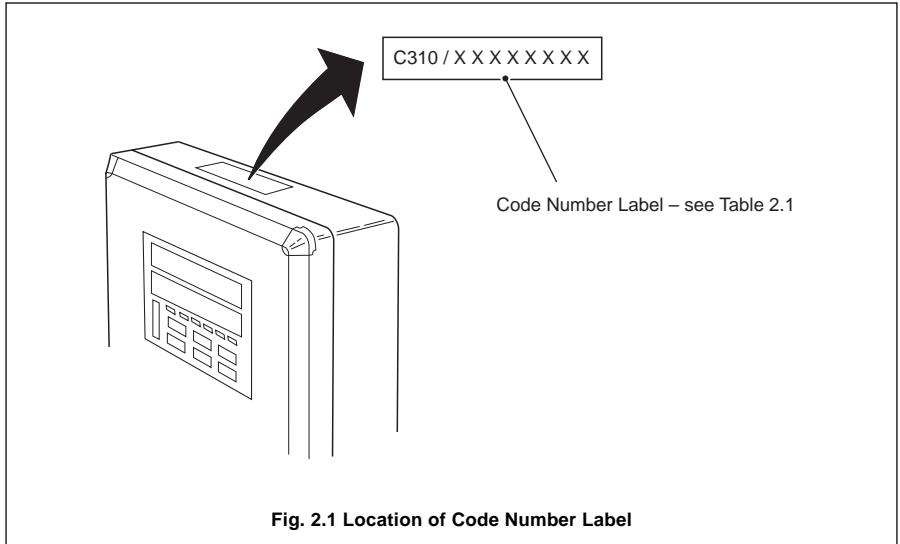

COMMANDER 310 Universal Process Controller		C310 /	XX	X	X	XXXX
<b>Option Board</b>	None RS485 Modbus Serial Comms.	00 01				
<b>Power Supply</b>	115V AC * 230V AC 24V AC			1 2 3		
<b>Build</b>	Standard CSA Approved CL1, DIV 2; CSA/FM				0 1 3	
<b>Configuration</b>	Configured to Factory Standards					<b>STD</b>
<b>Special Features</b>	Configured to Customers Details Agreed Special Feature					<b>CUS</b> <b>SPXX</b>

\* 115V AC versions are fitted with 0.5in NPT gland entry fixings – see Section 4.4.2

**Table 2.1 Identification of Instrument Code Number**

### 3 MECHANICAL INSTALLATION

#### EC Directive 89/336/EEC

In order to meet the requirements of the EC Directive 89/336/EEC for EMC regulations, this product must not be used in a non-industrial environment.

#### 3.1 Siting – Figs. 3.1 and 3.2

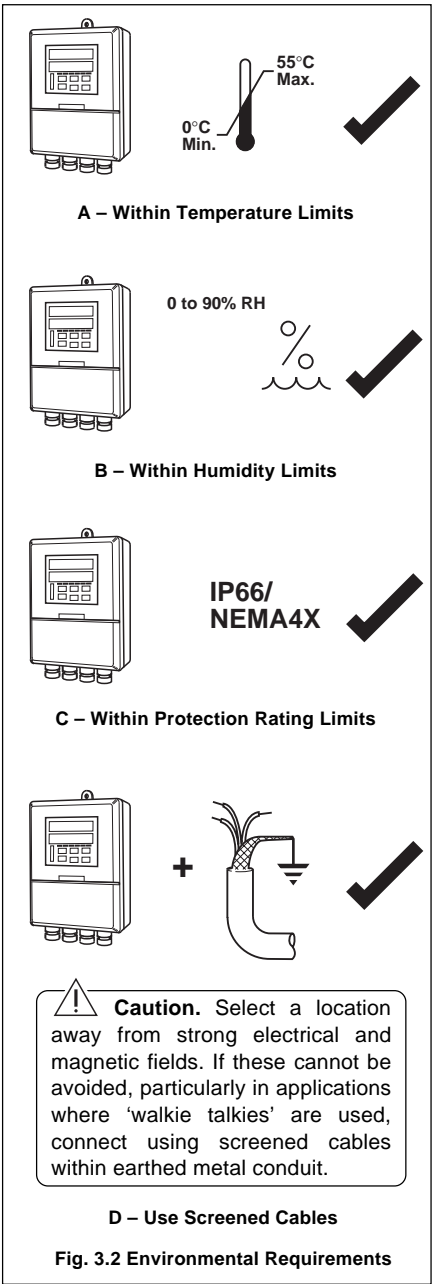
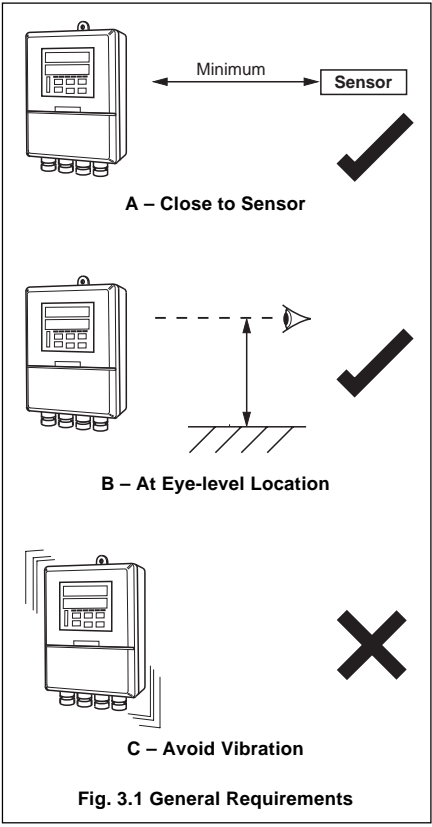

### 3.2 Mounting – Figs. 3.3 and 3.4

The instrument is designed for wall-/pipe-mounting – see Fig. 3.4. Overall dimensions are shown in Fig. 3.3.

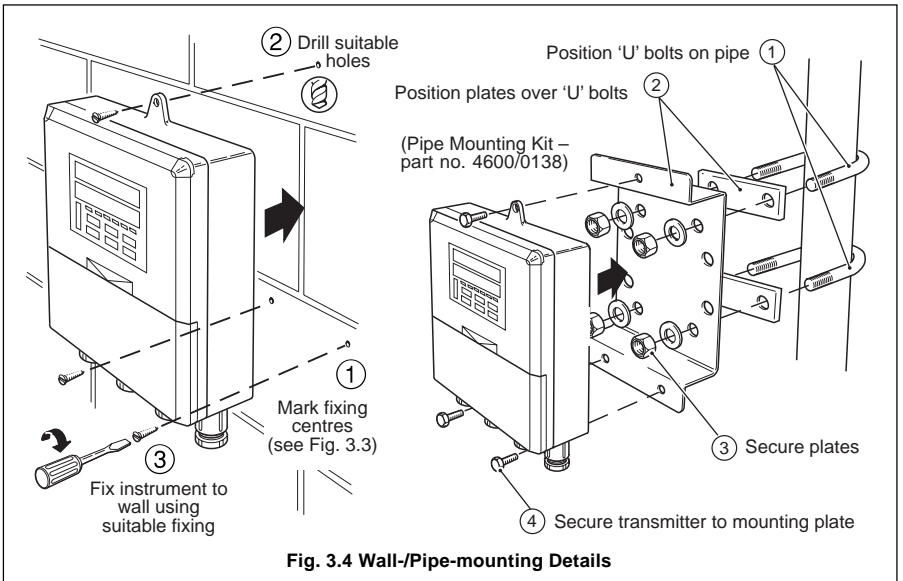
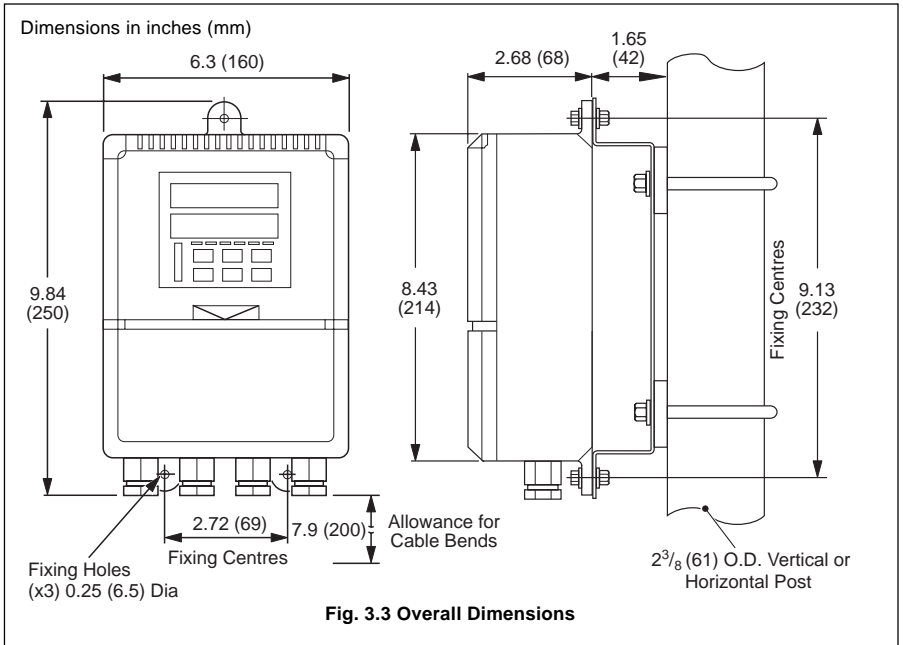

## 4 ELECTRICAL INSTALLATION



**Warning.** Before making any connections, ensure that the power supply, any high voltage-operated control circuits and high common mode voltages are switched off.



**Note.**

- Always route signal leads and power cables separately, preferably in earthed metal conduit.
- It is strongly recommended that screened cable is used for signal inputs and relay connections. Connect the screen to the ground stud.



**Information.** Use cable appropriate for the load currents. The terminals accept cables up 12AWG (2.5mm<sup>2</sup>).

### 4.1 Access to Terminals – Fig. 4.1

For access to terminals – refer to Fig. 4.1, steps ① to ③.

### 4.2 Setting the Input Selector Links – Fig. 4.2A

Plug-in links on the microprocessor p.c.b. are positioned according to the type of Process Variable Input, Remote Set Point Input and Valve Position Feedback Inputs used.

Remove the instrument front panel – see Fig. 4.1, steps ① to ⑥.

Referring to Fig. 4.2A, set the link positions for the input type required.

### 4.3 Setting the Isolated Output Link – Fig. 4.2B

A plug-in link (PL7) on the microprocessor p.c.b. is positioned according to the isolated output required, either a current proportioning control output (programmable in range 0 to 20mA) or a 12V logic output (minimum load 400Ω). Referring to Fig. 4.2B – steps ① and ②, set the link for the output type required.

To use a 12V logic output, the control type must be set to Time Proportioning Control – see Fig. 3.1 of the *Programming Guide*.

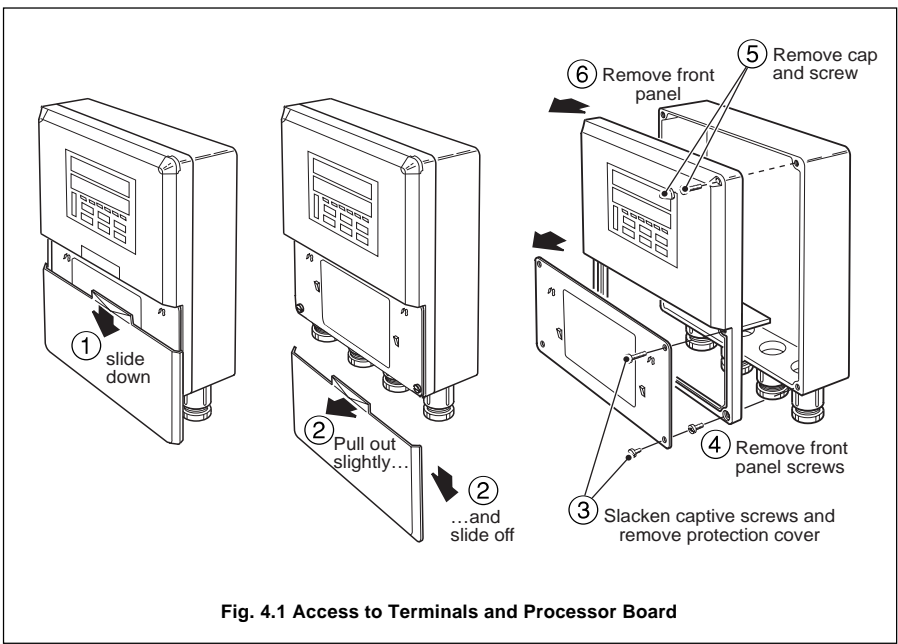

Fig. 4.1 Access to Terminals and Processor Board



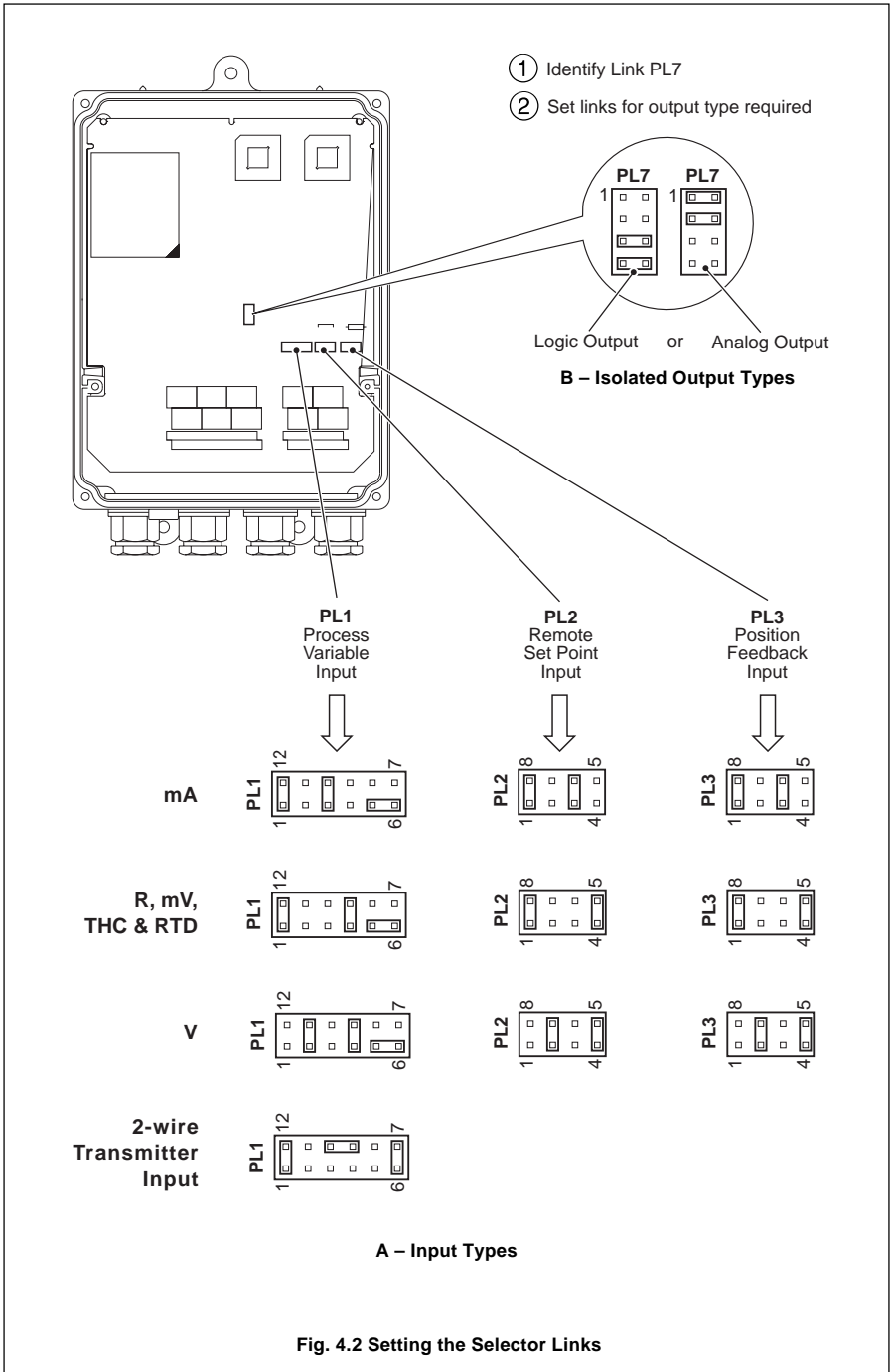

Fig. 4.2 Setting the Selector Links

4.4 Cable and Conduit Fixings

Glands

4.4.2 Conduit (N. American – 0.5in) – Fig. 4.4

Adaptors

4.4.1 Cable (IEC – 20mm) – Fig. 4.3

Glands

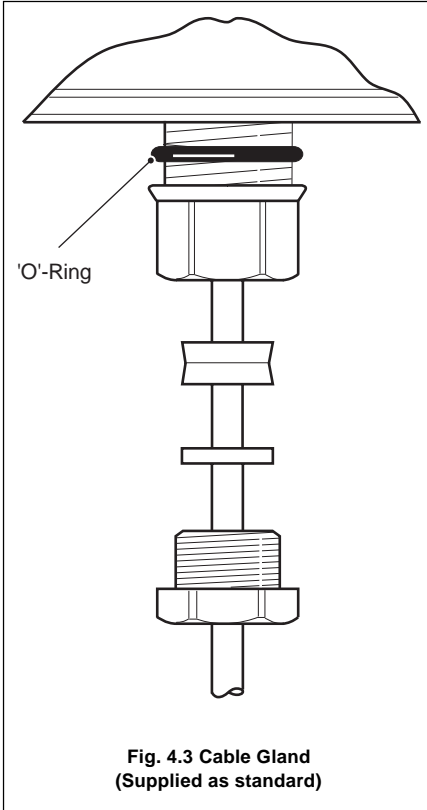

Fig. 4.3 Cable Gland (Supplied as standard)



**Warning.**

- Rigid conduit must NOT be fitted to the controller.
- Controller adaptors must incorporate a face seal.
- Torque settings for the hubs and outer nuts on the specified adaptors is 20ft. lbs minimum, 25ft. lbs. maximum.



**Information.**

- Suitable adaptors for controller (mandatory for FM installations):  
APPLETON  
ST-50 PLUS STG-50 or STB-50 PLUS STG-50.  
Reusable ONLY with replacement ferrule STF-50.  
O.Z. GEDNEY  
4Q-50, 4Q50T or 4Q-50TG.

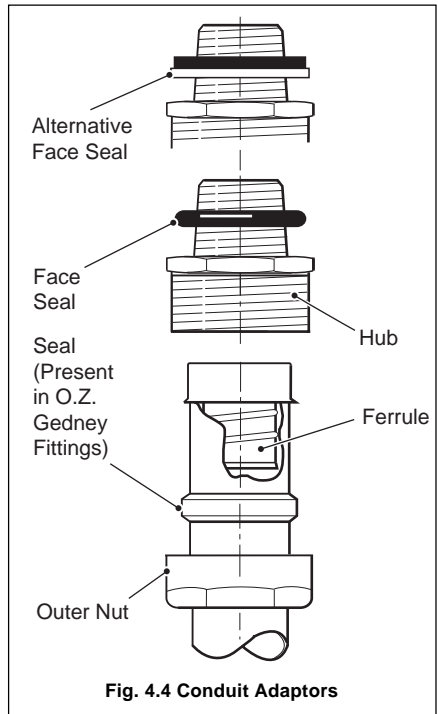

Fig. 4.4 Conduit Adaptors

### 4.4.3 Cable Glands (N. American – 0.5in) – Fig. 4.5



#### Warning.

- Controller glands must be fitted with a face seal.
- Torque settings (hubs only) – 20ft. lbs minimum, 25ft. lbs. maximum.
- Outer nuts – hand tight plus a half turn only.



#### Information.

- Suitable Cable Glands: (mandatory for FM installations):  
O.Z. GEDNEY  
SR-50-375 or SR-504  
APPLETON  
CG 3150 or CG-3150S (and STG-50 sealing ring).  
THOMAS & BETTS  
2521.
- When fitting cable glands to the controller, start with an outer gland and also temporarily fit a gland at the opposite end, to aid location of the transmitter gland plate. Fit and tighten glands consecutively from initial gland.

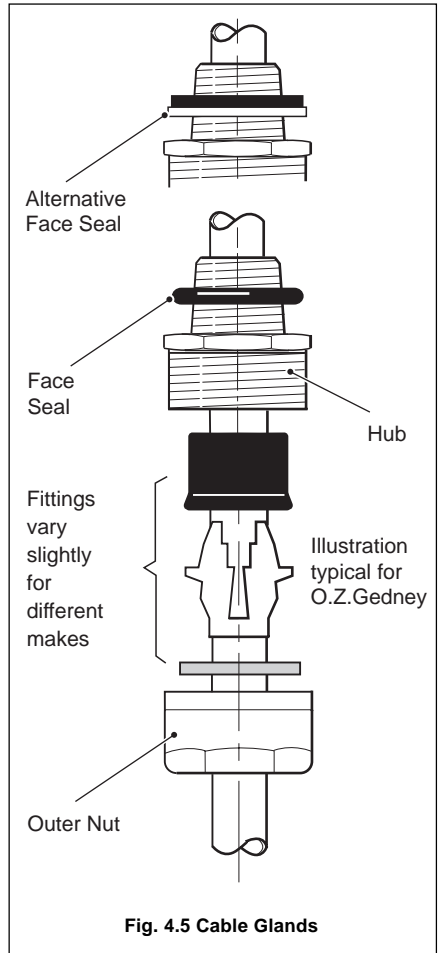
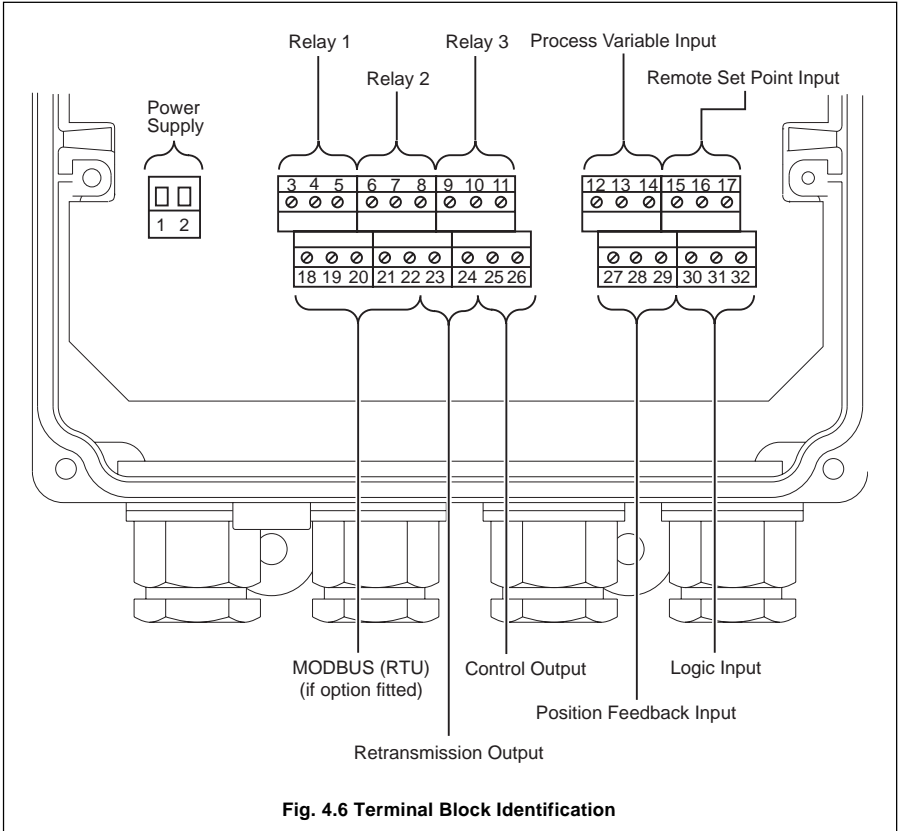

Fig. 4.5 Cable Glands

4.5 Connections Summary – Fig. 4.6

**i** Information.

Input impedances:  
 Low voltage(mV) >10MΩ  
 Voltage >10MΩ  
 Current 10Ω.



**Fig. 4.6 Terminal Block Identification**

Terminal Number			
<b>AC Supply</b>			
1	L	24V, 115V or 230V a.c.	} – see Fig. 4.22
2	N		
3	N/O	} Relay 1 Output – see Fig. 4.17	} Motorized Valve Control Relay (open) – see Fig. 4.19A
4	C		
5	N/C		
6	N/O	} Relay 2 Output – see Fig. 4.17	} Motorized Valve Control Relay (close) – see Fig. 4.19A
7	C		
8	N/C		
9	N/O	} Relay 3 Output – see Fig. 4.17	} Alarm Relays
10	C		
11	N/C		
12	3rd lead/2-wire TX	} Process Variable Input or 2-wire Tx Power Supply – see Figs. 4.7 to 4.9, 4.12 and 4.14	} – see Fig. 4.13
13	Input 1+		
14	Input 1–		
15	3rd lead	} Remote Set Point Input – see Figs. 4.7 to 4.12 and 4.14	
16	Input 2+		
17	Input 2–		
18	Tx+	} RS 485 Modbus Serial Communications Option 1 only – see <i>Modbus (RTU) Communications Supplement, IM/C310–MOD</i>	
19	Tx–		
20	Common		
21	Rx+		
22	Rx–		
23	+	} Retransmission Output/Cool Output – see Fig. 4.15	
24	–		
25	+	} Current Proportioning Control Output/Heat Output Fig. 4.15 or 12V Logic Control Output Fig. 4.16	
26	–		
27	3rd lead	} Position Feedback Input – see Figs. 4.18 , 4.19A and 4.19B	
28	Input 3+		
29	Input 3–		
30	}	Logic Input 1 – see Figs. 4.20 and 4.21	
31		Logic Input 2 – see Figs. 4.20 and 4.21	
32		Common	

Table 4.1 Electrical Connections

**4.6 Input Connections**

Make connections to each input, as shown in Figs 4.4 to 4.14, first removing any factory-fitted wire links not required.

**4.6.1 Thermocouple (THC) Inputs – Fig. 4.7**

\* **Note.** Automatic Cold Junction Compensation (ACJC) is active when an input is programmed for use with thermocouples. Use the correct compensating cable between the THC and the terminals – see Table 4.2.  
 If an external fixed cold junction is used, the connections to the instrument must be made with copper cable. The input must be programmed for mV input signals and the appropriate THC linearizer selected – see Sections 4.5 and 4.6 of the *Programming Guide*.

Type of Thermocouple	Compensating Cable			
	BS1843	ANSI MC 96.1	DIN 43714	BS4937 Part No.30
Ni-Cr/Ni-Al (K)	+ Brown – Blue Case Red	+ Yellow – Red Case Yellow	+ Red – Green Case Green	+ Green – White Case Green *
Nicrsil/Nisil ( N)	+ Orange – Blue Case Orange	+ Orange – Red Case Orange	—	+ Pink – White Case Pink *
Pt/Pt-Rh (R and S)	+ White – Blue Case Green	+ Black – Red Case Green	+ Red – White Case White	+ Orange – White Case Orange *
Cu/Cu-Ni (T)	+ White – Blue Case Blue	+ Blue – Red Case Blue	+ Red – Brown Case Brown	+ Brown – White Case Brown *
Fe/Con (J)	+ Yellow – Blue Case Black	+ White – Red Case Black	+ Red – Blue Case Blue	+ Black – White Case Black *
* Case Blue for intrinsically safe circuits				
Fe/Con (DIN 43710)	—	—	DIN 43710 + Blue/red – Blue Case Blue	—

**Table 4.2 Thermocouple Compensating Cables**

**4.6.2 3-lead Resistance Thermometer (RTD) Inputs – Fig. 4.8**

The three leads must have equal resistance, not exceeding 50Ω each.

**4.6.3 2-lead Resistance Thermometer (RTD) Inputs – Fig. 4.9**

If long leads are necessary it is preferable to use a 3-lead RTD. If the RTD is to be used in a hazardous area a 3-lead RTD must be used.

**4.6.4 Links for Unused Inputs**

To reduce susceptibility to electro-magnetic interference, ensure that the three terminals on each unused input are shorted together with sleeved wire links.

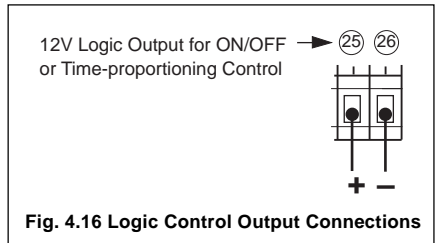
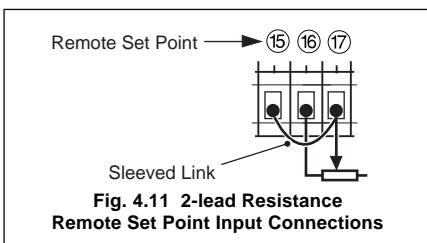
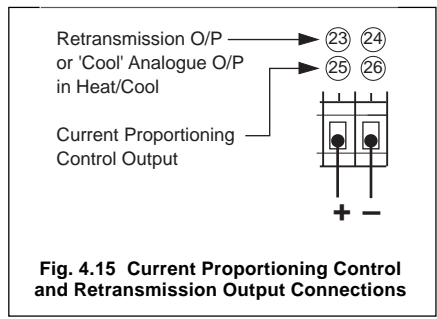
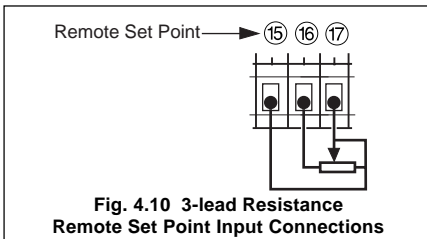
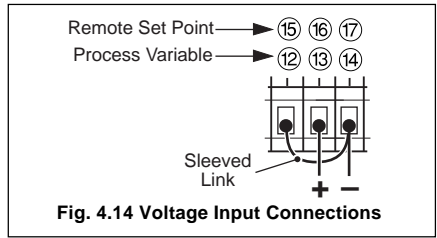
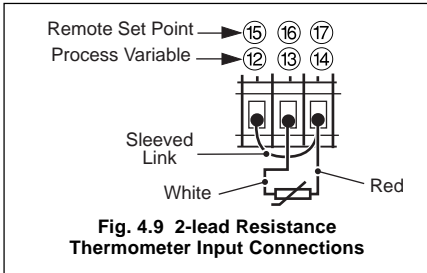
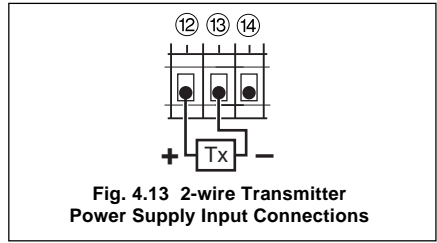
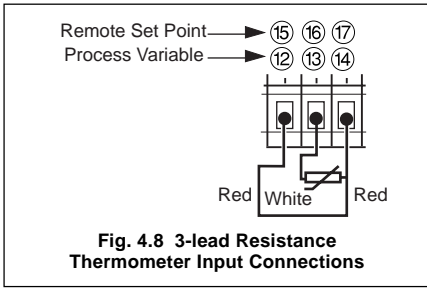
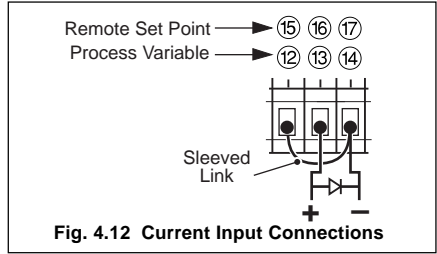
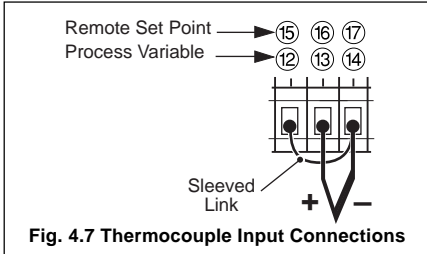

**4.7 Output Connections**

Make connections as shown in Figs 4.15 and 4.16.

**4.8 Relay Connections – Fig. 4.17**

For relay functions refer to the following table.

	Relay 1	Relay 2	Relay 3
On/Off Control	✓	—	—
Time Prop.(Heat)	✓	—	—
Time Prop.(Cool)	—	✓	—
Motorized Valve	Open	Close	—
Alarm	✓	✓	✓

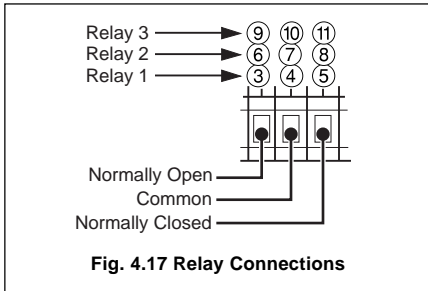

**4.9 Motorized Valve Connections – Figs. 4.18 and 4.19**

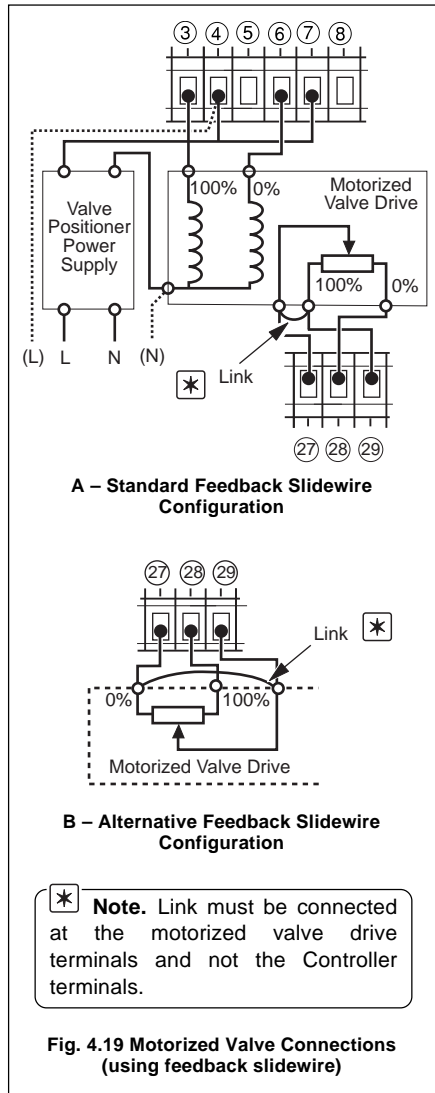
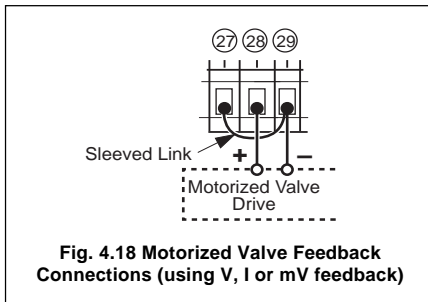



### 4.10 Logic Input Connections – Figs. 4.20 and 4.21

Each logic input can be programmed to perform one of a number of functions – see Section 3.10 of the *Programming Guide*.

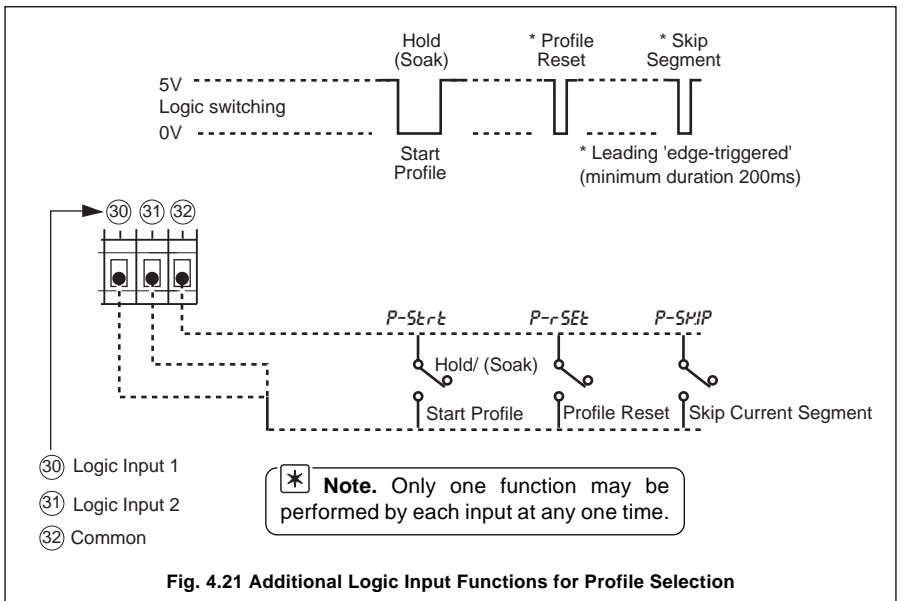
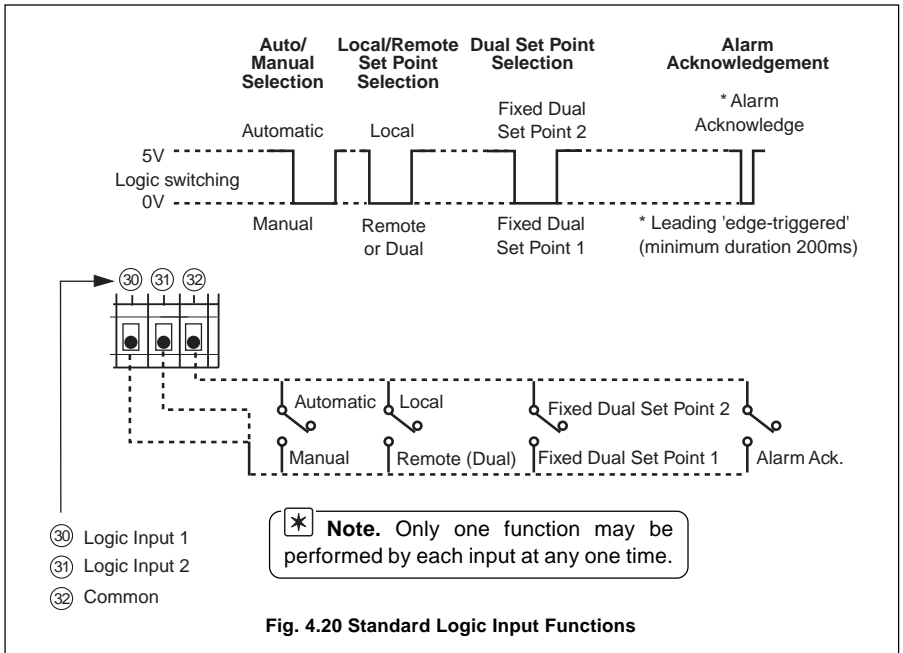

4.11 Power Supply Selection and AC Connections – Fig. 4.22

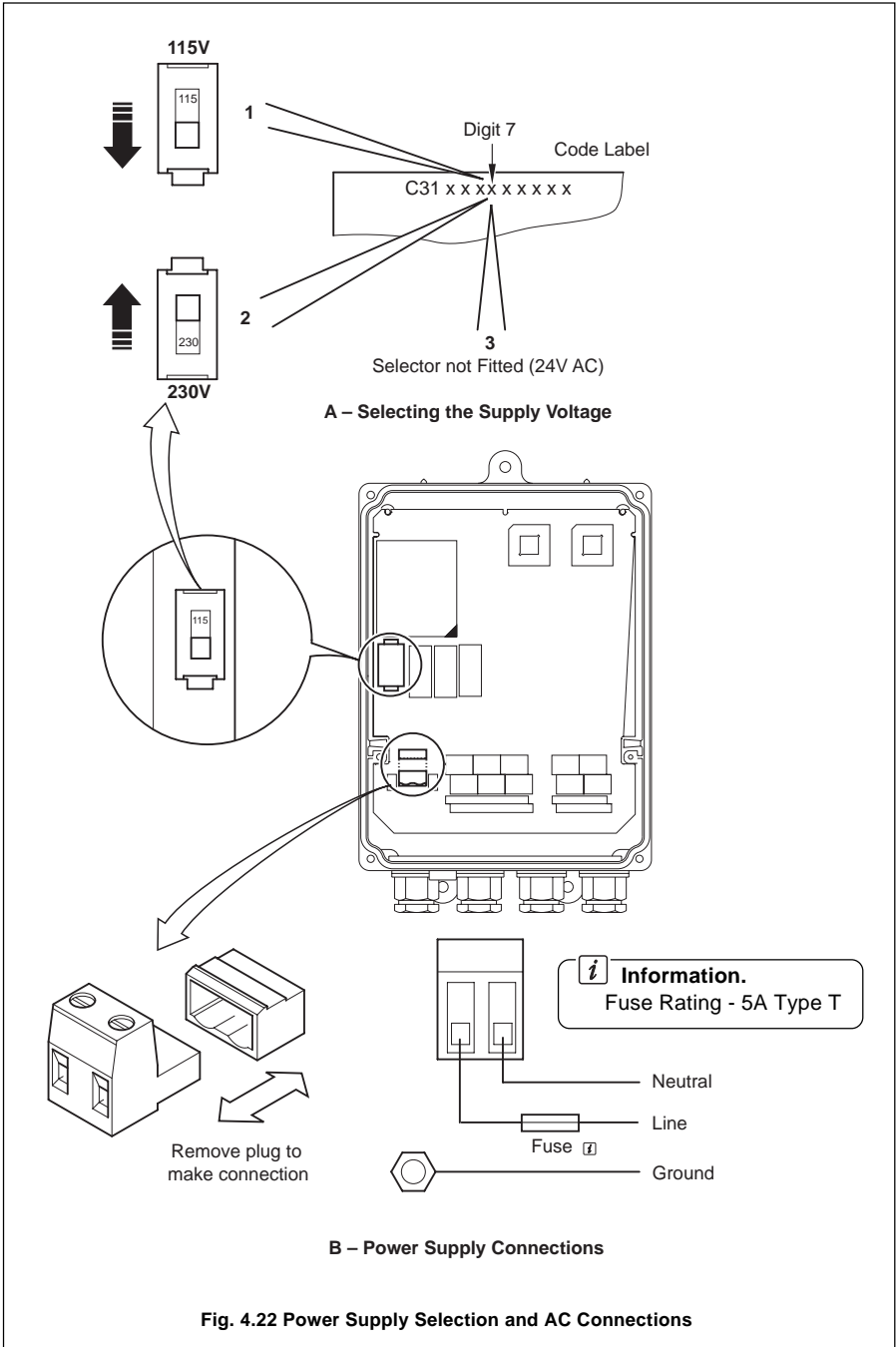
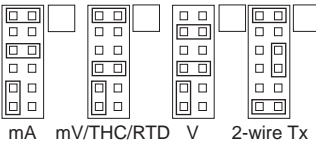
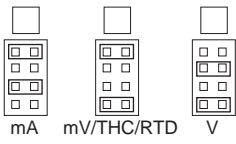
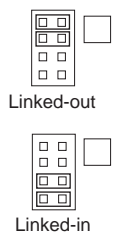





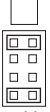

Fig. 4.22 Power Supply Selection and AC Connections

# 5 INSTALLATION RECORD

Connection/Terminal Number			
Power Supply	1	L	<b>Power Supply</b> <i>(Tick Box)</i> 230V AC <input type="checkbox"/> 24V AC <input type="checkbox"/> 115V AC <input type="checkbox"/>
	2	N	
Relay 1 Output	3	NO	<b>Output Type:</b>  <b>Output Function:</b>
	4	C	
	5	NC	
Relay 2 Output	6	NO	<b>Output Type:</b>  <b>Output Function:</b>
	7	C	
	8	NC	
Relay 3 Output	9	NO	<b>Output Type:</b>  <b>Output Function:</b>
	10	C	
	11	NC	
Process Variable Input	12	3rd	 <b>Link Positions</b> <i>(Tick Box)</i> mA mV/THC/RTD V 2-wire Tx
	13	+	
	14	-	
Remote Set Point Input	15	3rd	 <b>Link Positions</b> <i>(Tick Box)</i> mA mV/THC/RTD V
	16	+	
	17	-	
Modbus Serial Communications Option 1 only	18	Tx+	 <b>Termination Resistors</b> <i>(Tick Box)</i> Linked-out Linked-in
	19	Tx-	
	20	Common	
	21	Rx+	
	22	Rx-	
Retransmission Output	23	+	<b>Output Type:</b>  <b>Output Function:</b>
	24	-	

## ...5 INSTALLATION RECORD

### Connection/Terminal Number

Control Output	25	+			<b>Link Positions</b> <i>(Tick Box)</i>		
	26	-	Analog Output    Logic Output				
Position Feedback Input	27	3rd					<b>Link Positions</b> <i>(Tick Box)</i>
	28	+					
	29	-	mA    mV    R    V				
Logic Input 1	30						
Logic Input 2	31						
Common	32						

---

## NOTES

---



# PRODUCTS & CUSTOMER SUPPORT

## A Comprehensive Product Range

### Analytical Instrumentation

- **Transmitters**  
On-line pH, conductivity, and dissolved oxygen transmitters and associated sensing systems.
- **Sensors**  
pH, redox, selective ion, conductivity and dissolved oxygen.
- **Laboratory Instrumentation**  
pH and dissolved oxygen meters and associated sensors.
- **Water Analyzers**  
For water quality monitoring in environmental, power generation and general industrial applications including: pH, conductivity, ammonia, nitrate, phosphate, silica, sodium, chloride, fluoride, dissolved oxygen and hydrazine.
- **Gas Analyzers**  
Zirconia, paramagnetic, infrared, thermal conductivity.

### Controllers & Recorders

- **Controllers**  
Digital display, electronic, pneumatic. Discrete single-loop and multi-loop controllers which can be linked to a common display station, process computer or personal computer.
- **Recorders**  
Circular and strip-chart types (single and multi-point) for temperature, pressure, flow and many other process measurements.

### Electronic Transmitters

- **Smart & Analog Transmitters**  
For draft, differential, gauge and absolute pressure measurement. Also, liquid level and temperature.
- **I to P Converters and Field Indicators**

### Flow Metering

- **Magnetic Flowmeters**  
Electromagnetic, insertion type probes and watermeters.
- **Turbine Flowmeters**
- **Wedge Flow Elements**
- **Mass Flow Meters**  
Transmitters, sensors, controllers and batch/display units.

### Level Control

- **Submersible, Capacitance & Conductivity.**

### Pneumatic Instrumentation

- **Transmitters**
- **Indicating Controllers**
- **Recording Controllers**

## Customer Support

ABB Instrumentation provides a comprehensive after sales service via a Worldwide Service Organization. Contact one of the following offices for details on your nearest Service and Repair Centre.

### United Kingdom

ABB Kent-Taylor Limited  
Tel: +44 (0)1480 475321  
Fax: +44 (0)1480 470787

### United States of America

ABB Instrumentation Inc.  
Tel: +1 716 292 6050  
Fax: +1 716 273 6207

### Italy

ABB Kent-Taylor SpA  
Tel: +39 (0) 344 58111  
Fax: +39 (0) 344 56278

### Client Warranty

Prior to installation, the equipment referred to in this manual must be stored in a clean, dry environment, in accordance with the Company's published specification. Periodic checks must be made on the equipment's condition.

In the event of a failure under warranty, the following documentation must be provided as substantiation:

1. A listing evidencing process operation and alarm logs at time of failure.
2. Copies of operating and maintenance records relating to the alleged faulty unit.



The Company's policy is one of continuous product improvement and the right is reserved to modify the information contained herein without notice.

© ABB 1998

Printed in UK (6.98)

---

**ABB Kent-Taylor Ltd.**  
St. Neots  
Cams.  
England, PE19 3EU  
Tel: +44 (0) 1480 475321  
Fax: +44 (0) 1480 217948

**ABB Instrumentation Inc.**  
PO Box 20550, Rochester  
New York 14602-0550  
USA  
Tel: +1 716 292 6050  
Fax: +1 716 273 6207

**ABB Kent-Taylor SpA**  
22016 Lenno  
Como  
Italy  
Tel: +39 (0) 344 58111  
Fax: +39 (0) 344 56278