

Use of Instructions



Warning.

An instruction that draws attention to the risk of injury or death.



Note.

Clarification of an instruction or additional information.



Caution.

An instruction that draws attention to the risk of damage to the product, process or surroundings.



Information.

Further reference for more detailed information or technical details.

Although **Warning** hazards are related to personal injury, and **Caution** hazards are associated with equipment or property damage, it must be understood that operation of damaged equipment could, under certain operational conditions, result in degraded process system performance leading to personal injury or death. Therefore, comply fully with all **Warning** and **Caution** notices.

Information in this manual is intended only to assist our customers in the efficient operation of our equipment. Use of this manual for any other purpose is specifically prohibited and its contents are not to be reproduced in full or part without prior approval of Technical Communications Department, ABB Instrumentation.

Health and Safety

To ensure that our products are safe and without risk to health, the following points must be noted:

1. The relevant sections of these instructions must be read carefully before proceeding.
2. Warning labels on containers and packages must be observed.
3. Installation, operation, maintenance and servicing must only be carried out by suitably trained personnel and in accordance with the information given.
4. Normal safety precautions must be taken to avoid the possibility of an accident occurring when operating in conditions of high pressure and/or temperature.
5. Chemicals must be stored away from heat, protected from temperature extremes and powders kept dry. Normal safe handling procedures must be used.
6. When disposing of chemicals ensure that no two chemicals are mixed.

Safety advice concerning the use of the equipment described in this manual or any relevant hazard data sheets (where applicable) may be obtained from the Company address on the back cover, together with servicing and spares information.

GETTING STARTED

This manual is divided into 5 sections which contain all the information needed to install, configure, commission and operate the COMMANDER 150. Each section is identified clearly by a symbol as shown below.



Displays and Controls

- Displays and function keys
- LED Indication
- Error Messages



Operator Mode (Level 1)

- Operator menus for:
 - *Standard Indicator*
 - *Totalizer/Batch Controller*
 - *Maximum/Minimum/Average Indicator*



Set Up Mode (Level 2)

- Alarm trip points
- Totalizer functions



Configuration Mode (Levels 3 and 4)

- Accessing the configuration levels
- Level 3
 - Hardware assignment and input type
 - Alarm types and hysteresis
 - Operator functions and totalizer setup
 - Digital input and serial communications
- Level 4
 - Ranges and passwords



Installation

- Siting
- Mounting
- Electrical connections

Symbol Identification and Section Contents

CONTENTS

1	DISPLAYS AND FUNCTION KEYS	3
1.1	Introduction	3
1.2	Use of Function Keys	4
1.3	LED Alarms and Indicators	5
1.4	Error Messages	6
2	OPERATOR MODE	7
2.1	Introduction	7
2.2	Operating Page – Standard	8
2.3	Operating Page – Totalizer	9
2.3	Operating Page – Totalizer	10
2.4	Operating Page – Maths Functions	11
3	SET UP MODE	13
3.1	Introduction	13
3.2	Set Up Level	14
4	CONFIGURATION MODE	18
4.1	Introduction	18
4.2	Accessing the Configuration Mode	18
4.3	Basic Hardware and Configuration (Level 3)	20
4.3.1	Hardware Assignment and Input Type	20
4.3.2	Alarms	22
4.3.3	Operator Functions and Totalizer Set Up	24
4.3.4	Digital Input and Serial Communications	26
4.4	Ranges and Passwords (Level 4)	28
5	INSTALLATION	31
5.1	Siting	31
5.2	Mounting	33
5.3	Electrical Connections	35
5.4	Relays, Arc Suppression, Inputs and Outputs	35
5.4.1	Relay Contact Ratings	35
5.4.2	Arc Suppression	35
5.4.3	Logic Output	35
5.4.4	Control or Retransmission Analog Output	35
5.4.5	Digital Input	35

1 DISPLAYS AND FUNCTION KEYS



Information.

The fold-out page inside on the back cover of this manual shows all the frames in the programming levels. Space is provided on the page for writing the programmed setting or selection for each frame.

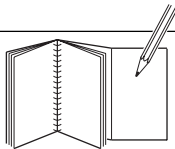

1.1 Introduction – Fig. 1.1

The COMMANDER 150 front panel display, function keys and LED indicators are shown in Fig. 1.1.

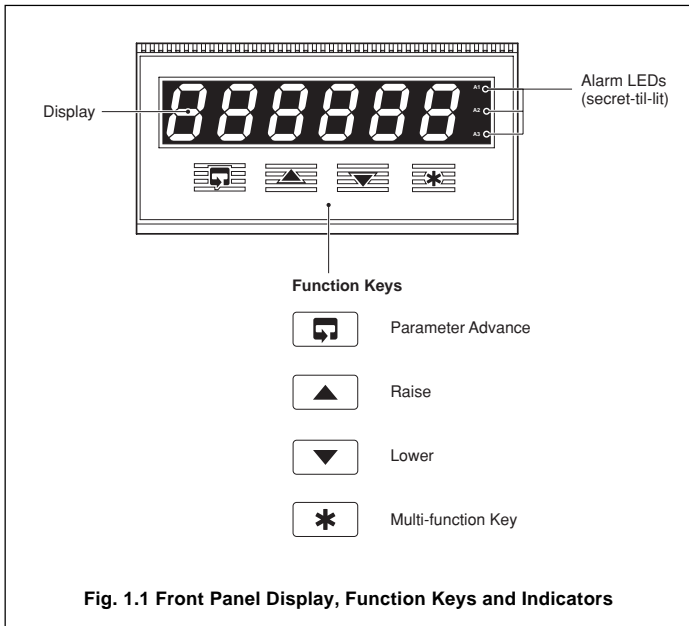
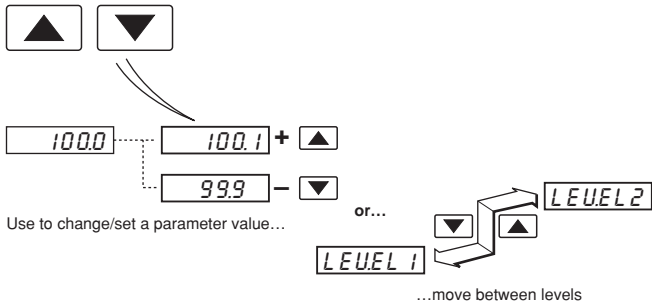

Fig. 1.1 Front Panel Display, Function Keys and Indicators

1.2 Use of Function Keys – Fig. 1.2

A – Raise and Lower Keys



B – Parameter Advance Key

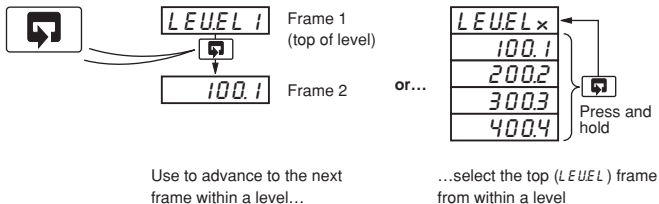

Note. This key also stores any changes made in the previous frame

C – Multi-function Key

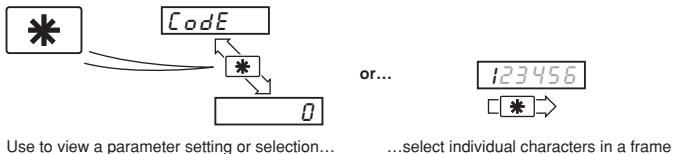
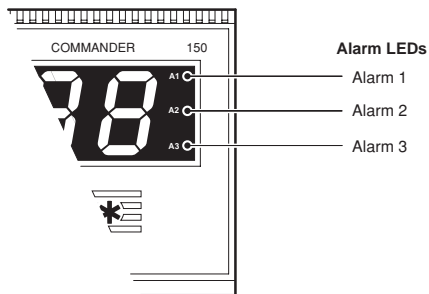

Fig. 1.2 Use of Function Keys

1.3 LED Alarms and Indicators



LED Status

All Flashing





- Indicator is in the configuration mode – see Section 4.2.

A1, A2 and A3

- Flashes when Alarm is active (off when inactive).
- Lit constantly when Alarm 1 is an active latched alarm which has been acknowledged

Fig. 1.3 LED Alarms and Indicators

1.4 Error Messages

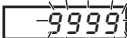
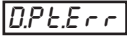
Display	Error/Action	To Clear Display
	Calibration error Turn mains power off and on again (if the error persists contact the Service Organization).	Press the key
	Configuration error The configuration and/or setup data for the instrument is corrupted. Turn mains power off and on again (if error persists, check configuration/setup settings).	Press the  key
	A to D Converter Fault The analog to digital converter is not communicating correctly.	Turn power on and off again. If the error persists, contact the Service Organization
	Process Variable Over/Under Range	Restore valid input
	Option board error Communications to the option board have failed.	Contact the Service Organization



2.1 Introduction

Operator Mode (Level 1) is the normal day-to-day mode of the COMMANDER 150.

Frames displayed in level 1 are determined by the indicator functions which are selected during configuration of the instrument – see Section 4.



Note. Only the operating frames relevant to the configured functions are displayed in Operator Mode.

The three indicator functions are:

- **Standard Indicator** – page 8
- **Indicator with Totalization** – page 9
- **Indicator with Max./Min./Average** – page 11



2.2 Operating Page – Standard (Level 1)

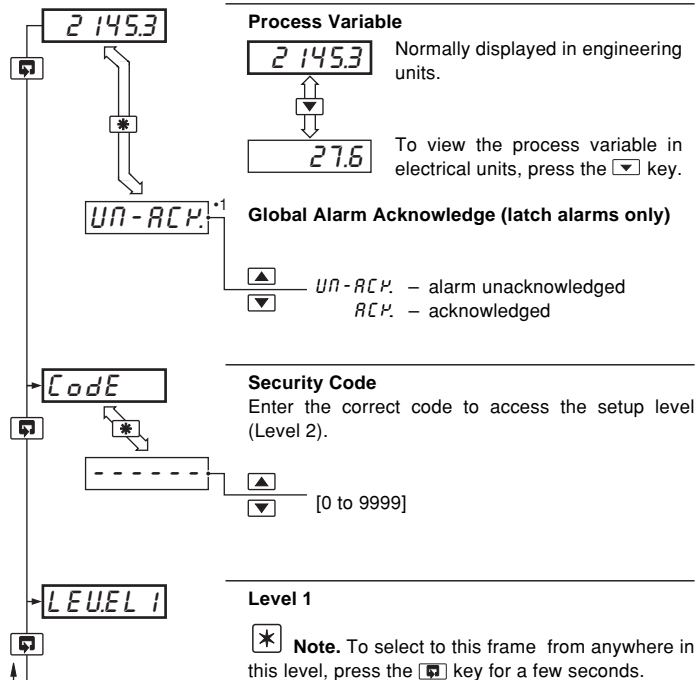

•1 Only displayed if there is an active latch alarm.



2.3 Operating Page – Totalizer (Level 1)

These frames are only displayed if the totalizer function is enabled in the configuration level – see Section 4.3.3

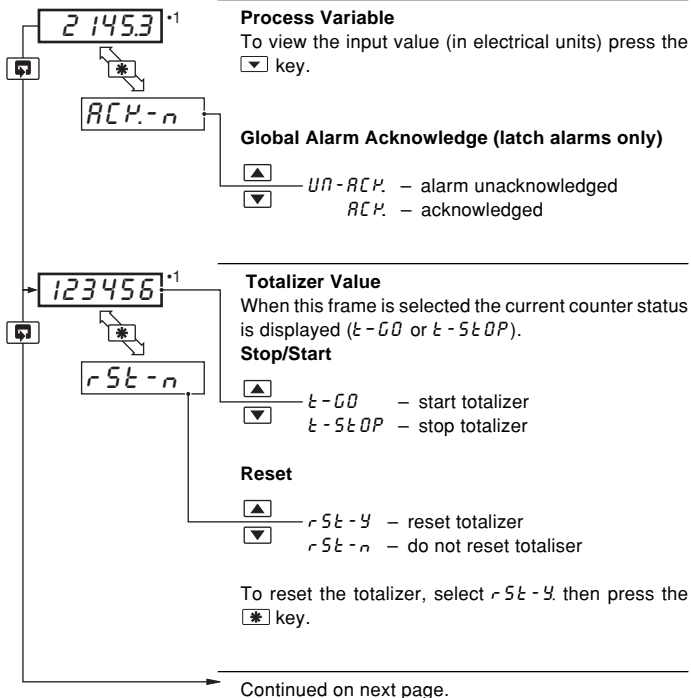

- 1 Totalizer stop/go and reset from these frames can be disabled – see Section 4.3.3.
A digital input can also be used to start/stop or reset the totalizer – see Section 4.3.4



2.3 Operating Page – Totalizer (Level 1)

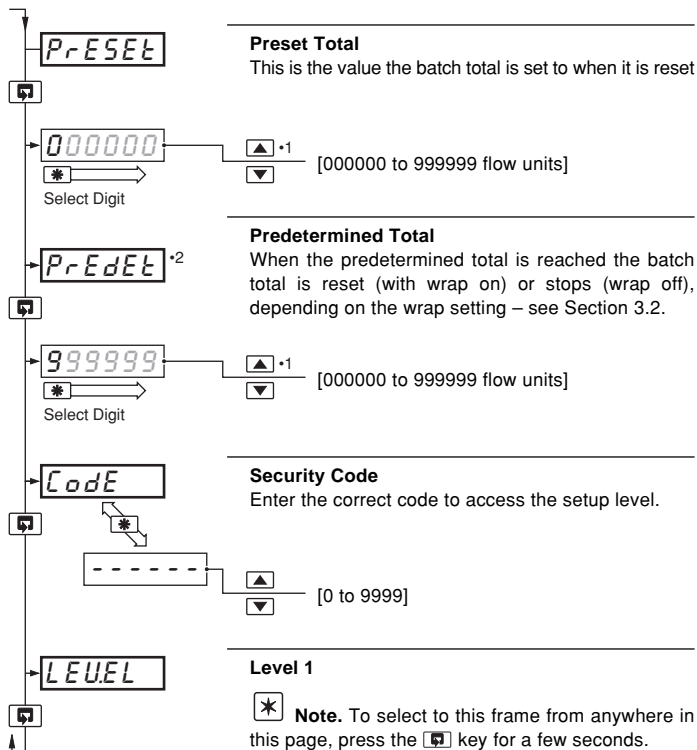

- ¹ The predetermined value should be greater than the preset value when the totalizer is counting up and lower than the preset value when the totalizer is counting down.
- ² Only displayed if enabled in the configuration level – see Section 4.3.3.



2.4 Operating Page – Maths Functions (Level 1)



Note. It is possible to have totalizer and maths functions together.

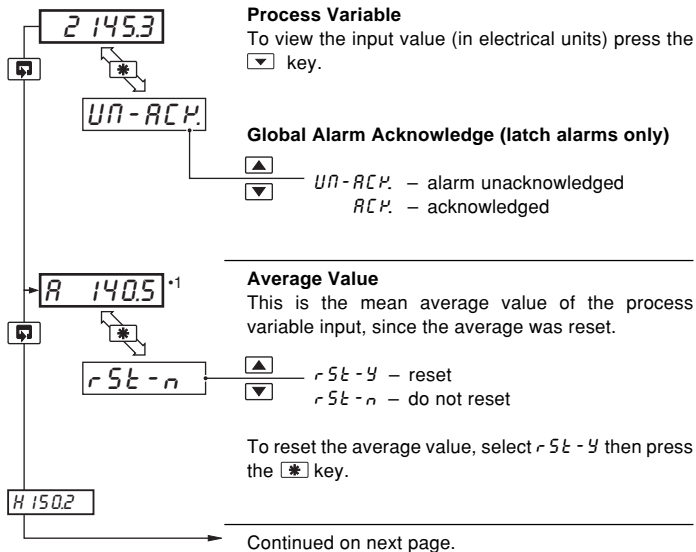

- 1 This frame can be disabled – see Section 4.3.3.

The average value is reset automatically on power-up and can also be reset from a digital input – see Section 4.3.4.

The reset function in this frame can be disabled – see Section 4.3.3.



...2.4 Operating Page – Maths Functions (Level 1)



Maximum Value

This is the maximum value of the process variable since the maximum was reset.

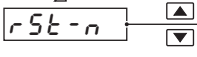

▲ *rSt-y* – reset
▼ *rSt-n* – do not reset

To reset the maximum value, select *rSt-y* then press the  key.

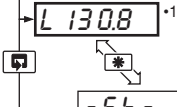

Minimum Value

This is the minimum value of the process variable since the minimum was reset.

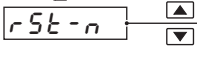

▲ *rSt-y* – reset
▼ *rSt-n* – do not reset

To reset the minimum value, select *rSt-y* then press the  key.

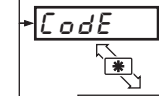

Security Code

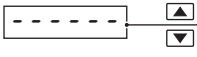

Enter the correct code to access the setup level.



▲ [0 to 9999]
▼



Level 1

 **Note.** To select to this frame from anywhere in this page, press the  key for a few seconds.

- 1 This frame can be disabled – see Section 4.3.3.

The average value is reset automatically on power-up and can also be reset from a digital input – see Section 4.3.4.

The reset reset function in this frame can be disabled – see Section 4.3.3.

12



3 SET UP MODE

3.1 Introduction

To access the Setup Level (Level 2) the correct password must be entered in the security code frame (Code) in Level 1— see Fig. 3.1.

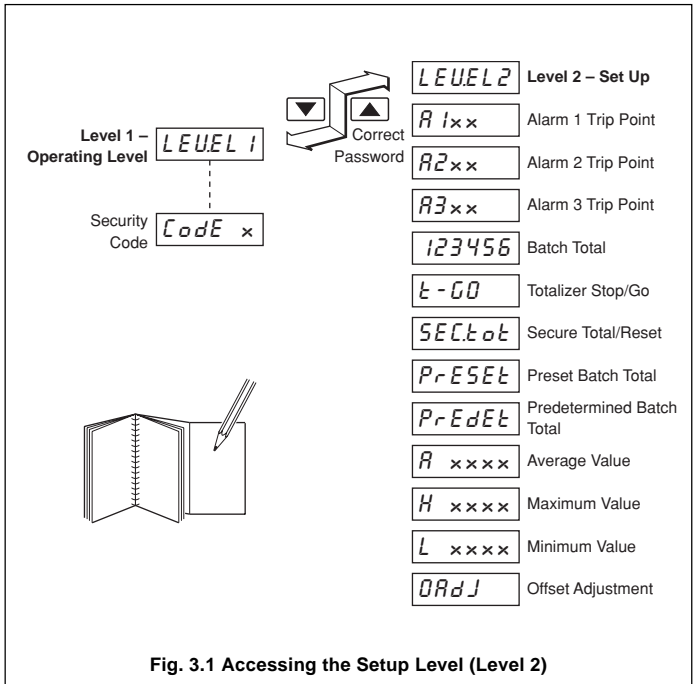

Fig. 3.1 Accessing the Setup Level (Level 2)

3.2 Setup Level (Level 2)

Level 2

Note. To select to this frame from anywhere in this level, press the key for a few seconds.

Alarm 1 Trip Point
Alarm type:
A1hP = High process alarm
A1lP = Low process alarm
A1HL = Latched high process alarm
A1LL = Latched low process alarm

[In engineering units]

Alarm 1 Hysteresis Value

[In engineering units]

Alarm 2 Trip Point
Alarm type

[In engineering units]

Alarm 2 Hysteresis Value

[In engineering units]

A3hP

Continued on next page.

- 1 Not displayed if the alarm is disabled ('None' selected) – see Section 4.3.2.
- 2 Only displayed if custom alarm hysteresis is selected – see section 4.3.2



...3.2 Setup Level (Level 2)

Alarm 3 Trip Point
Alarm type
▲ [In engineering units]
▼

Alarm 3 Hysteresis Value
▲ [In engineering units]
▼

Totalizer Value
▲ *rSt-y* – reset
▼ *rSt-n* – do not reset
To reset the maximum value, select *rSt-y* then press the * key.

Totalizer Stop/Go
▲ *t-go* – start totalizer
▼ *t-stop* – stop totalizer
Setting to *t-go* starts the totalizer counting towards the predetermined value. Setting to *t-stop* holds the totalizer at its present value.

Continued on next page

- 1 Not displayed if the alarm is disabled ('NONE' selected) – see section 4.3.2
- 2 Only displayed if custom alarm hysteresis is selected – see section 4.3.2
- 3 Only displayed if enabled in the Configuration Level – see section 4.3.3
- 4 A digital input can also be used to reset the batch total.

...3.2 Set Up Level (Level 2)

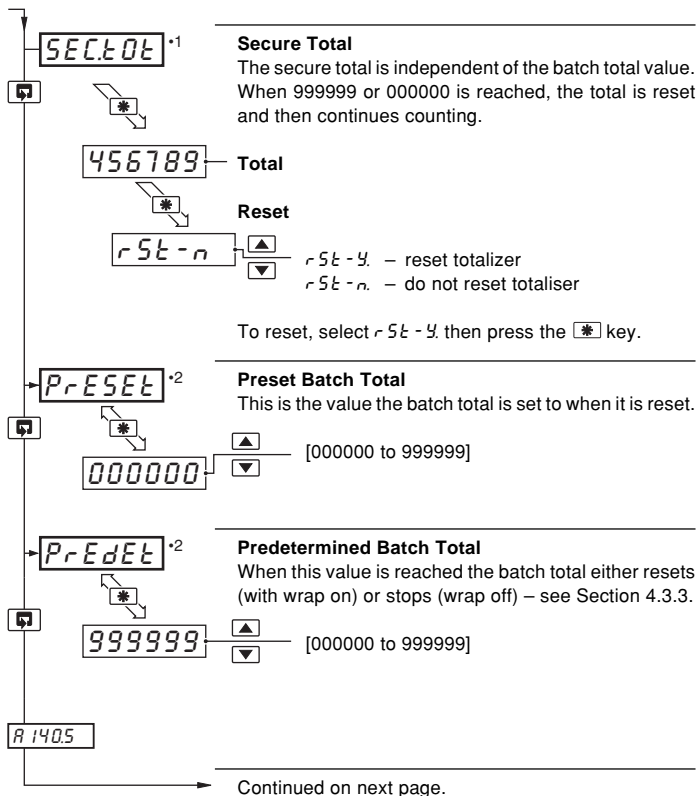

*1 Only displayed if enabled in the Configuration Level – see Section 4.3.3.

*2 The preset value must be lower than the predetermined value when counting up, and greater than the predetermined value when counting down.



...3.2 Set Up Level (Level 2)

Average Value
 This is the mean average value of the process variable input since the average was reset.

▲ *rSt-y* – reset
 ▼ *rSt-n* – do not reset

To reset, select *rSt-y*. then press the key.

Maximum Value
 This is the maximum value of the process variable since the maximum was reset.

▲ *rSt-y* – reset
 ▼ *rSt-n* – do not reset

To reset, select *rSt-y*. then press the key.

Minimum Value
 This is the minimum value of the process variable since the minimum was reset.

▲ *rSt-y* – reset
 ▼ *rSt-n* – do not reset

To reset, select *rSt-y*. then press the key.

Offset Adjustment
 An offset can be applied to the process variable input to enable spot calibration or the removal of system errors.

▲ [±10% of engineering range]
 ▼

- *1 The average value is reset automatically on power-up and can also be reset from a digital input – see Section 4.3.4.
- *2 The maximum and minimum values are reset automatically on power-up and can also be reset from a digital input – see Section 4.3.4.

4.1 Introduction

The Configuration Mode comprises two levels (3 and 4) as shown in Fig. 4.2.

Configuration level 3 is divided into four frames. For most simple applications it is only necessary to set up the parameters in the first frame.

*** Note.**

When in the configuration level:

- All the l.e.d. indicators flash.
- All relays and logic outputs are turned off.
- The analog output reverts to 0% (4mA) output level.

4.2 Accessing the Configuration Mode – Fig. 4.1

To access the Configuration Mode set the security switch to the 'Configure' position (levels 1 and 2 cannot be accessed from this setting). When the configuration parameters are programmed, reset the security switch to the 'Normal' position and the Operating page is displayed automatically .

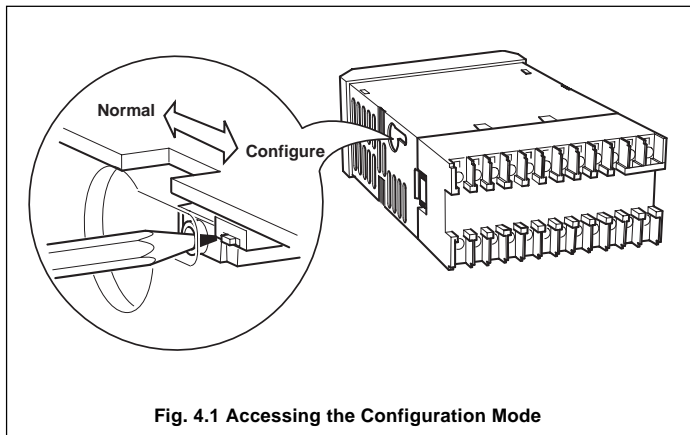

Fig. 4.1 Accessing the Configuration Mode

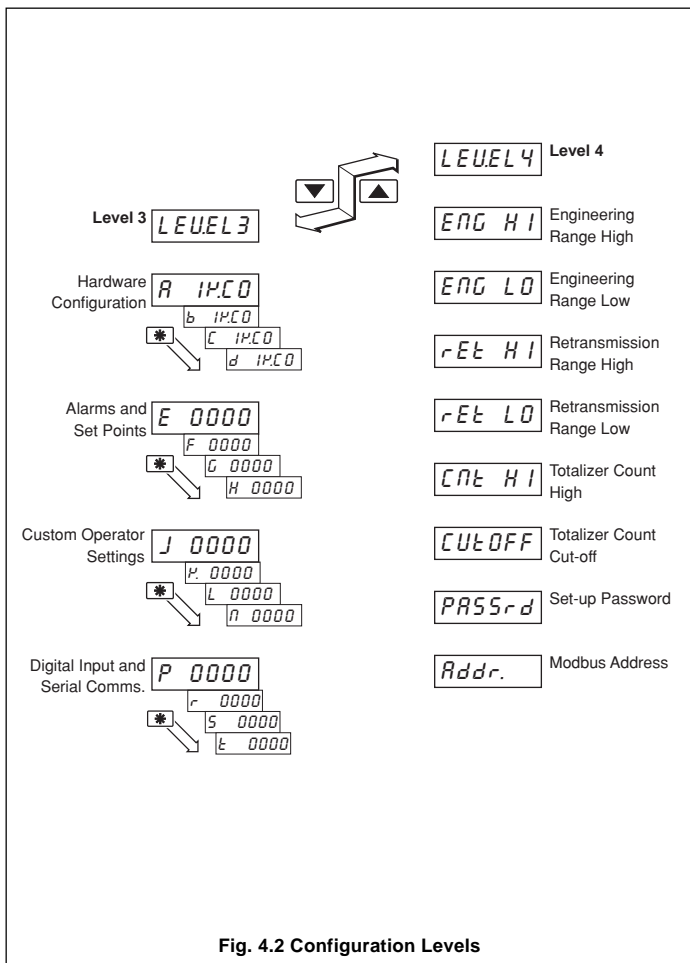
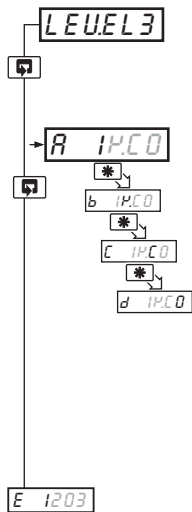



Fig. 4.2 Configuration Levels

4.3 Basic Hardware and Configuration (Level 3) – Fig. 4.3

4.3.1 Hardware Assignment and Input Type



Level 3

***** **Note.** To select to this frame from anywhere in this level, press the  key for a few seconds.

'ABCD' Settings

The first character (A, b, C or d) identifies the parameter to be changed. The current setting is indicated by a flashing letter. Parameter options are shown in Fig. 4.3.

- R = Hardware configuration
- b = Input type and range
- C = Temperature units
- d = No. of decimal points

***** **Note 1.** The temperature ranges default to their maximum values when the input type is changed.

***** **Note 2.** For custom settings contact the local distributor.

Continued on page 22.

Information.

Count High Calculation

Convert flow rate into units/sec = $\frac{\text{actual engineering flow rate}}{\text{flow range time units (in seconds)}}$

Count High = $\frac{\text{units/sec}}{\text{counter factor}}$ resultant must be >0.001 and <99.999pps.

Counter factor is the engineering value of the least significant digit shown on the totalizer display – see Section 4.3.3.

Totalizer Count Pulse

The totalizer count pulse is on for a preset time of 250ms and off for a minimum of 250ms.

A – Hardware Configuration

50Hz/60Hz		Relay 1 Source	Relay 2* Source	Relay 3* Source	Logic O/P Source	Analog O/P Source
<i>1</i>	<i>A</i>	Alarm 1	Alarm 2	Alarm 3	TCP**	PV
<i>2</i>	<i>b</i>	Alarm 1	Alarm 2	Alarm 3	TWP**	PV
<i>3</i>	<i>C</i>	TCP**	Alarm 1	Alarm 2	TWP**	PV
<i>4</i>	<i>d</i>	TWP**	Alarm 1	Alarm 2	TCP**	PV
<i>5</i>	<i>E</i>	Alarm 1	Alarm 2	Alarm 3	TCP**	PV Average
<i>U</i>		Custom	Custom	Custom	Custom	Custom

TCP = Totalizer Count Pulse TWP = Totalizer Wrap Pulse PV = Process Variable

* Only available if the appropriate option board is fitted.

** Pulse energizes assigned relay

B – Input Type and Range Configuration

Display		Display	
<i>b</i>	THC Type B	<i>1</i>	0 to 20 mA
<i>E</i>	THC Type E	<i>2</i>	4 to 20 mA
<i>J</i>	THC Type J	<i>3</i>	0 to 5 V
<i>K</i>	THC Type K	<i>4</i>	1 to 5 V
<i>N</i>	THC Type N	<i>5</i>	0 to 50 mV
<i>R</i>	THC Type R	<i>7</i>	4 to 20 mA (square root lineariser)
<i>S</i>	THC Type S	<i>U</i>	Custom Configuration
<i>t</i>	THC Type T		
<i>P</i>	PT100 RTD		

C – Temperature Units

Display	Temperature Units
<i>C</i>	Degrees C*
<i>F</i>	Degrees F*
<i>0</i>	No temperature units

* Temperature inputs only

D – Process Variable Display Decimal Places

Display	
<i>0</i>	xxxx
<i>1</i>	xxx . x
<i>2</i>	xx . xx
<i>3</i>	x . xxx
<i>4</i>	x . xxxx

Fig. 4.3 Hardware Configuration and Input/Output Ranges

4.3.2 Alarms – Figs. 4.4 and 4.5

* **Note.** Relays assigned to alarms are de-energized in the alarm state.

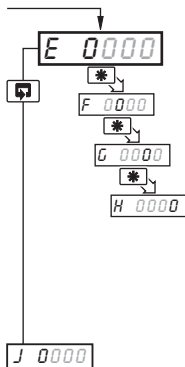

'EFGH' Settings

The first character (E, F, G or H) identifies the parameter to be changed. The current setting is indicated by a flashing letter. Parameter options are shown in Fig. 4.5.

- E = Alarm 1 type
- F = Alarm 2 type
- G = Alarm 3 type
- H = Alarm hysteresis

* **Note.** For custom settings contact the local distributor.

Continued on page 24.

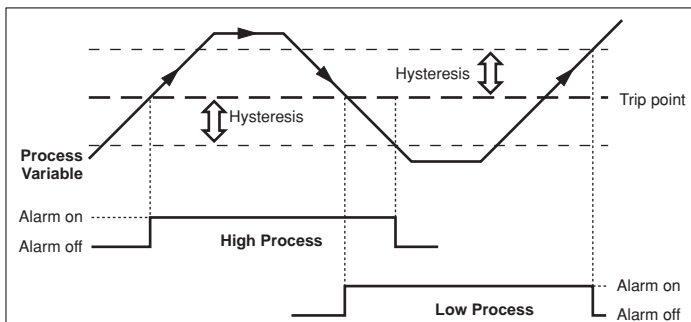

Information.

For latch alarms the relay remains de-energised until acknowledged in Level 1 (or by a digital input)

Fig. 4.4 Alarm Action



E 0000 E – Alarm 1 Type

Display	
0	None
1	High Process
2	Low Process
3	High Latch
4	Low Latch

F 0000 F – Alarm 2 Type

Display	
0	None
1	High Process
2	Low Process
3	High Latch
4	Low Latch

G 0000 G – Alarm 3 Type

Display	
0	None
1	High Process
2	Low Process
3	High Latch
4	Low Latch

h 0000 H – Alarm Hysteresis

Display	
0	None
1	0.1%
2	0.2%
3	0.5%
4	1.0%
5	2.0%
6	5.0%
U	Custom

} Value in % of engineering range

} Value in engineering units *

Note. When custom alarm hysteresis is selected, the alarm hysteresis values are set individually in the **Set Up Level** – See section 3.2

Fig. 4.5 Alarm Setup

4.3.3 Operator Functions and Totalizer Set Up – Fig. 4.6

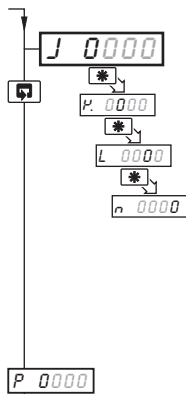

'JKLN' Settings

The first character (J, K, L or N) identifies the parameter to be changed. The current setting is indicated by a flashing letter. Parameter options are shown in Fig. 4.6.

- J = Totalizer set-up
- P. = No. of decimal places for totalizer
- L = Operator level frame enable
- n = Operator level functions enable/disable

***** **Note.** For custom settings contact the local distributor.

Continued on page 26.



J 0000 J – Totalizer Setup

Display	
0	Off
1	Count Up, Wrap Off
2	Count Up, Wrap On
3	Count Down, Wrap Off
4	Count Down, Wrap On

K. 0000 K – Totalizer Display
Decimal Places

Display	
0	xxxxxx
1	xxxxx.x
2	xxxx.xx
3	xxx.xxx
4	xx.xxxx
5	x.xxxxx

L 0000 L – Operator Level Frame Enable

Display	Max/Min Values Displayed	Average Value Displayed	Preset/Predetermined Values Displayed
0	No	No	No
1	Yes	No	No
2	Yes	Yes	No
3	No	Yes	Yes
4	No	No	Yes
5	Yes	No	Yes
6	Yes	Yes	Yes

This frame determines which frames appear in the operating page (level 1)

n 0000 N – Operator Level Math Function & Totaliser Control Enable

Display	Totalizer Stop/Go	Totalizer Reset	Max./Min./Average
0	No	No	No
1	Yes	No	No
2	No	Yes	No
3	Yes	No	Yes
4	No	Yes	Yes
5	Yes	Yes	Yes

This frame determines which functions the operator can control

Fig. 4.6 Totalizer Setup and Operator Functions

4.3.4 Digital Input and Serial Communications – Figs. 4.7 and 4.8

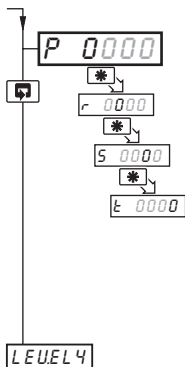

'PRST' Settings

The first character (P, R, S or T) identifies the parameter to be changed and the current setting is indicated by a flashing letter. Parameter options are shown in Fig. 4.8.

- P = Digital input function
- r = Analog input filter
- S = Serial communications configuration
- t = Serial communications parity

***** **Note.** For custom settings contact the local distributor.

Continued on page 28.

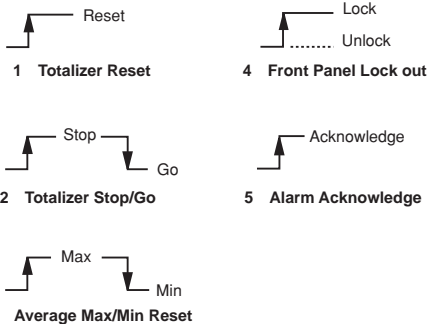

Information.

Digital input options 1, 2, 3 and 5 are edge-triggered to enable the front panel keys to change the function when the digital input is operational.

Fig. 4.7 Digital Function Configuration



P 0000 P – Digital Input Function

Display	
0	None
1	Totalizer Reset
2	Totalizer Stop/Go
3	Average, Max/Min Reset
4	Front Panel Lockout
5	Alarm Acknowledge

r 0000 R – Analog Input Filter

Display	
0	0 seconds
1	1 second
2	2 seconds
5	5 seconds
8	10 seconds
b	20 seconds
c	40 seconds
d	60 seconds

5 0000 S – Serial Communication Configuration

Display	Baud Rate, 2/4 Wire
0	Off
1	2400, 2 Wire
2	2400, 4 Wire
3	9600, 2 Wire
4	9600, 4 Wire

t 0000 T – Serial Communication Parity

Display	
0	None
1	Odd
2	Even



Note. Settings for options P, S and T are only available if the appropriate option board is fitted.

Fig. 4.8 Digital Function and Serial Communications Configuration

4.4 Ranges and Passwords (Level 4)

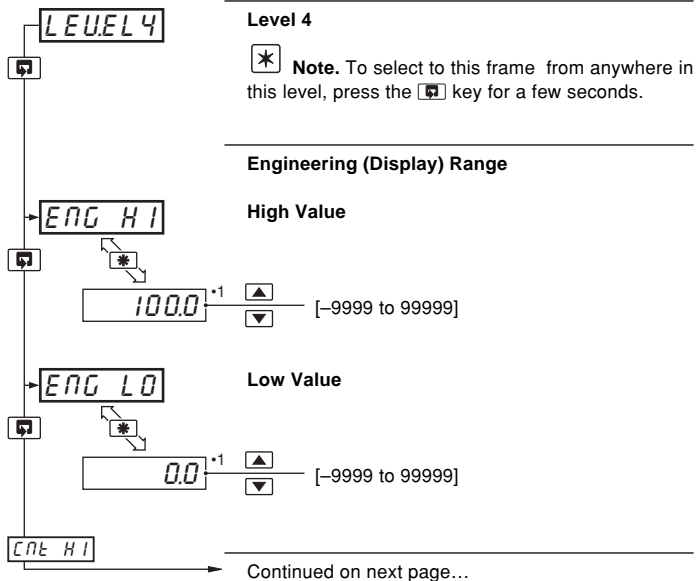

- *1 The engineering range high and low values are automatically set to the maximum allowed value when thermocouple or RTD is selected in the configuration level – see Section 4.3.1. This value can be modified if required.



...4.4 Ranges and Passwords (Level 4)

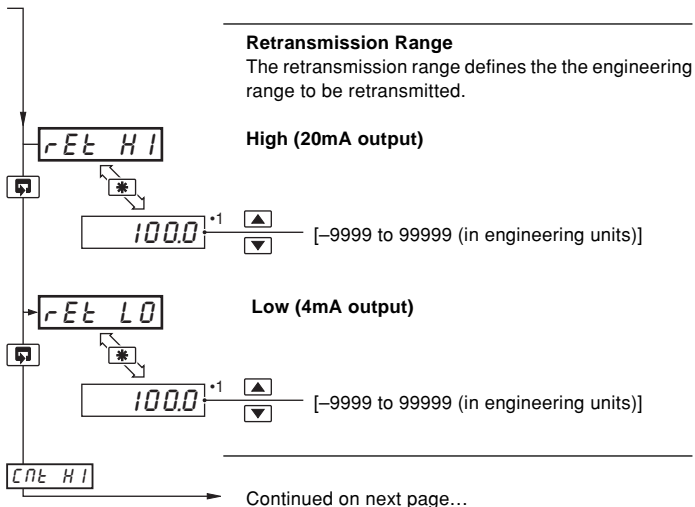

- *1 The retransmission range high and low values are automatically set to the maximum allowed value when thermocouple or RTD is selected in the configuration level – see Section 4.3.1. This value can be modified if required.

...4.4 Ranges and Passwords (Level 4)

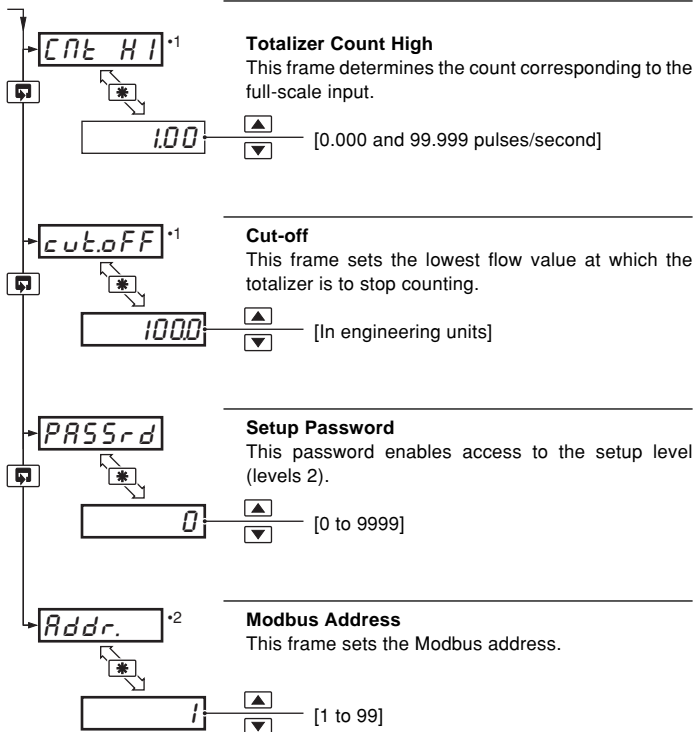

•1 Only displayed if enabled in the configuration level – see Section 4.3.3.

•2 Only available if the appropriate option board is fitted.

5 INSTALLATION



5.1 Siting – Figs. 5.1 and 5.2

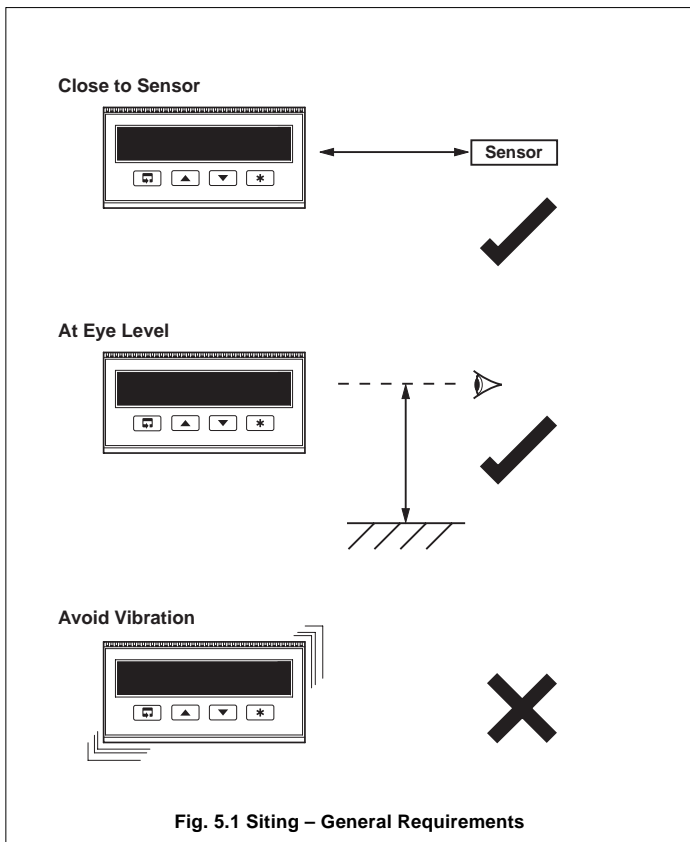

Fig. 5.1 Siting – General Requirements



...5 INSTALLATION

...5.1 Siting – Figs. 5.1 and 5.2

Temperature Limits

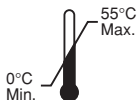
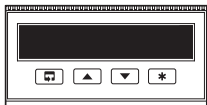

Humidity Limits

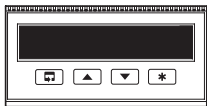

0 to 90% RH



Environmental Limits

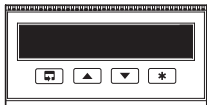

IP65/NEMA3
(front panel)

IP20
(rear)

Use Screened Cable

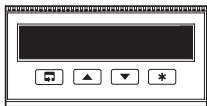
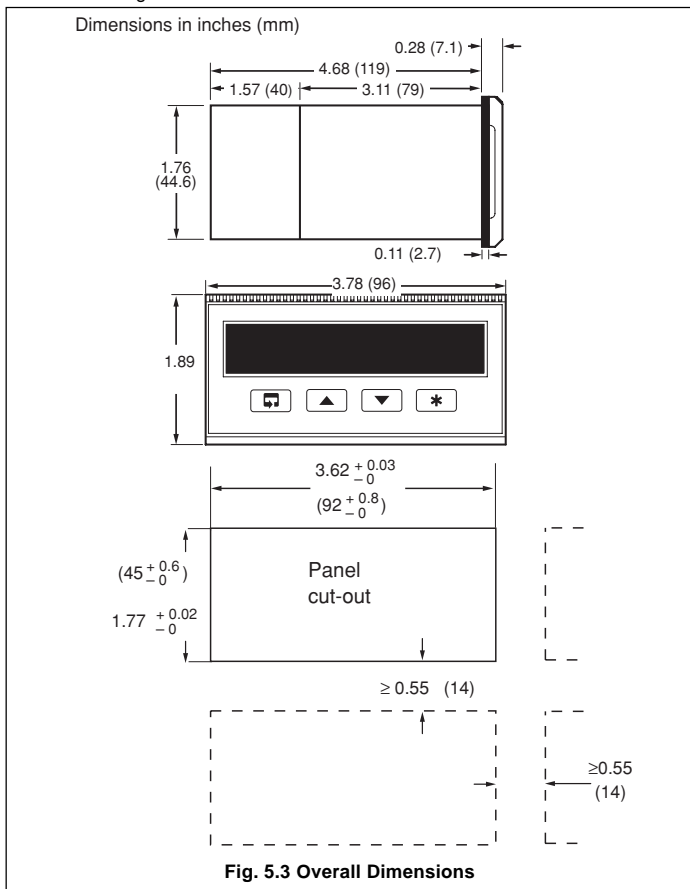

Fig. 5.2 Environmental Requirements



5.2 Mounting – Figs. 5.3 and 5.4

The instrument is designed for panel mounting (see Fig. 5.4). Overall dimensions are shown in Fig. 5.3.





...5.2 Mounting – Figs. 5.3 and 5.4

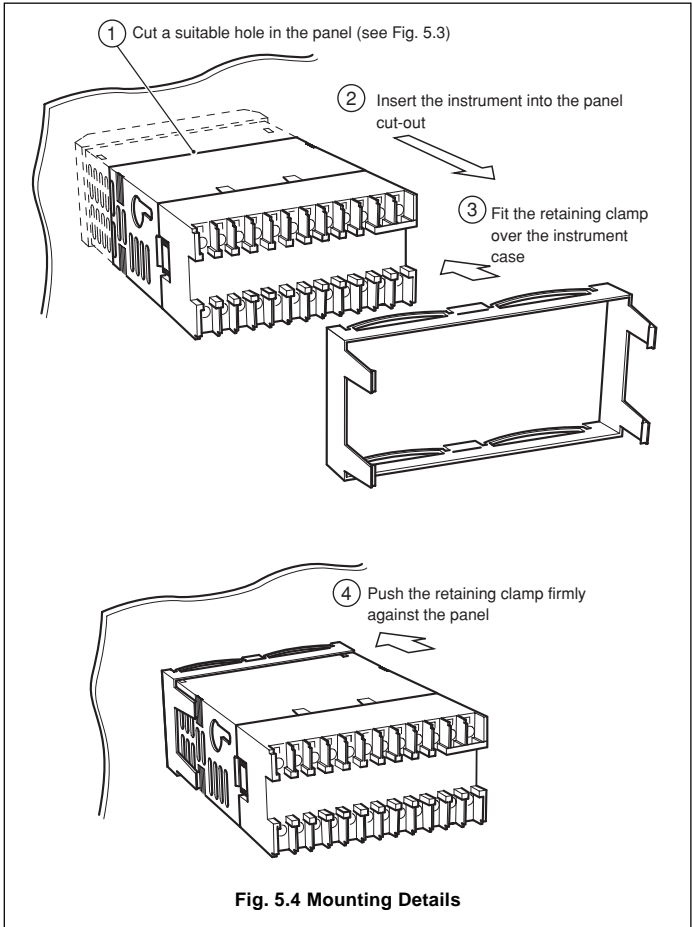

Fig. 5.4 Mounting Details



EC Directive 89/336/EEC

In order to meet the requirements of the EC Directive 89/336/EEC for EMC regulations, this product must not be used in a non-industrial environment.

5.3 Electrical Connections – Fig. 5.5 (overleaf)



Warning. Before making any connections, ensure that the power supply, any powered control circuits and high common mode voltages are switched off.



Note. If it is not possible to avoid strong electrical and magnetic fields, screened cables within earthed metal conduit must be used.

5.4 Relays, Arc Suppression, Inputs and Outputs

5.4.1 Relay Contact Ratings

Relay contacts are rated at:

115/230V AC at 5A (non-inductive)

250V DC 25W max.

5.4.2 Arc Suppression

Arc suppression components are fitted to relays 2 and 3 only. If relay 1 is required to switch inductive loads, fit the arc suppression components supplied.

5.4.3 Logic Output

18V DC at 20mA

Min load 900 Ω

Isolated from Analog Input (not isolated from Retransmission O/P).

Dielectric strength: 500V d.c. for 1 minute.

5.4.4 Retransmission Analog Output

Max. load 15V (750 Ω at 20mA)

Isolated from Analog Input (not isolated from Logic O/P).

Dielectric strength: 500V d.c. for 1 minute.

5.4.5 Digital Input

Type: Volt-free

Minimum Pulse: 250 ms

...5 INSTALLATION

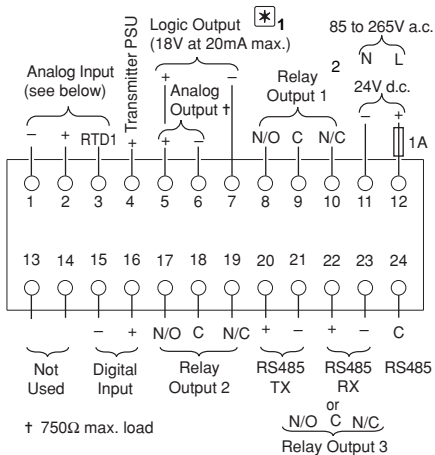

*** Note 1.** The Analog Output and Logic Output use a common positive terminal, capable of driving both outputs simultaneously.

*** Note 2.** Fit arc suppression components if switching inductive loads.

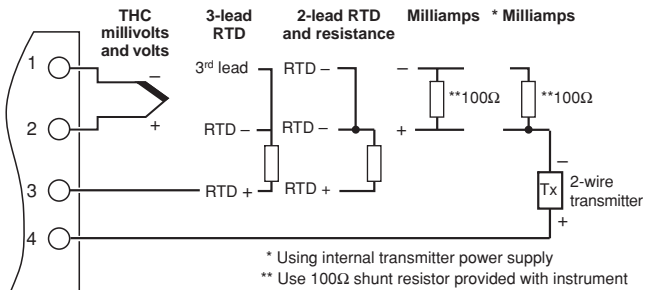

Fig. 5.5 Electrical Connections

Customer Support

ABB Instrumentation provides a comprehensive after sales service via a Worldwide Service Organization. Contact one of the following offices for details on your nearest Service and Repair Centre.

United Kingdom

ABB Instrumentation Limited

Tel: +44 (0)1480 475321

Fax: +44 (0)1480 470787

United States of America

ABB Automation Inc.

Instrumentation Division

Tel: +1 215-674-6000

Fax: +1 215-674-7183

Italy

ABB Kent-Taylor SpA

Tel: +39 (0) 344 58111

Fax: +39 (0) 344 58278

Client Warranty

Prior to installation, the equipment referred to in this manual must be stored in a clean, dry environment, in accordance with the Company's published specification. Periodic checks must be made on the equipment's condition.

In the event of a failure under warranty, the following documentation must be provided as substantiation:

1. A listing evidencing process operation and alarm logs at time of failure.
2. Copies of operating and maintenance records relating to the alleged faulty unit.



The Company's policy is one of continuous product improvement and the right is reserved to modify the information contained herein without notice.

© ABB 2000

Printed in UK (8.00)

IM/C150 Issue 9

ABB Instrumentation Ltd

St. Neots
Cams.
England, PE19 3EU
Tel: +44 (0) 1480 475321
Fax: +44 (0) 1480 217948

**ABB Automation Inc.
Instrumentation Division**

125 E. County Line Road
Warminster, PA 18974 USA
Tel: +1 215-674-6000
Fax: +1 215-674-7183

ABB Kent-Taylor SpA

22016 Lenno
Como
Italy
Tel: +39 (0) 344 58111
Fax: +39 (0) 344 58278



CUSTOMER CONFIGURATION LOG



LEVEL3

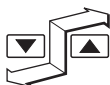

LEVEL4

ENG HI _____

R 1P.CO

ENG LO _____

A _ B _ C _ D _

rEt HI _____

E 0000

rEt LO _____

E _ F _ G _ H _

CNt HI _____

J 0000

CUTOFF _____

J _ K _ L _ N _

P 0000

PASSrd _____

P _ R _ S _ T _

Addr. _ _

CUSTOMER SETUP LOG



LEVEL 1

Code

LEVEL 2

R 1xx

R 2xx

R 3xx

xxxxxx

t-GO

SEctot

PrESEt

PrEdEt

R xxxx

H xxxx

L xxxx

DRdJ

Instrument Serial Number: _____

Product Code: C 1 5 0 / _ _ _ _ / _ _ _ _