

# Advanced Circular Chart Recorder

C1300



# ABB

## The Company

We are an established world force in the design and manufacture of instrumentation for industrial process control, flow measurement, gas and liquid analysis and environmental applications.

As a part of ABB, a world leader in process automation technology, we offer customers application expertise, service and support worldwide.

We are committed to teamwork, high quality manufacturing, advanced technology and unrivalled service and support.

The quality, accuracy and performance of the Company's products result from over 100 years experience, combined with a continuous program of innovative design and development to incorporate the latest technology.

The NAMAS Calibration Laboratory No. 0255 is just one of the ten flow calibration plants operated by the Company, and is indicative of our dedication to quality and accuracy.

BS EN ISO 9001:1994



Cert. No. Q05907

EN 29001 (ISO 9001)



Lenno, Italy – Cert. No. 9/90A

Stonehouse, U.K.



0255

## Electrical Safety

This instrument complies with the requirements of CEI/IEC 61010-1:2001-2 'Safety Requirements for Electrical Equipment for Measurement, Control and Laboratory Use'. If the instrument is used in a manner NOT specified by the Company, the protection provided by the instrument may be impaired.

## Symbols

One or more of the following symbols may appear on the instrument labelling:

	<b>Warning</b> – Refer to the manual for instructions
	<b>Caution</b> – Risk of electric shock
	Protective earth (ground) terminal
	Earth (ground) terminal

	Direct current supply only
	Alternating current supply only
	Both direct and alternating current supply
	The equipment is protected through double insulation

Information in this manual is intended only to assist our customers in the efficient operation of our equipment. Use of this manual for any other purpose is specifically prohibited and its contents are not to be reproduced in full or part without prior approval of the Technical Publications Department.

### Health and Safety

To ensure that our products are safe and without risk to health, the following points must be noted:

1. The relevant sections of these instructions must be read carefully before proceeding.
2. Warning labels on containers and packages must be observed.
3. Installation, operation, maintenance and servicing must only be carried out by suitably trained personnel and in accordance with the information given.
4. Normal safety precautions must be taken to avoid the possibility of an accident occurring when operating in conditions of high pressure and/or temperature.
5. Chemicals must be stored away from heat, protected from temperature extremes and powders kept dry. Normal safe handling procedures must be used.
6. When disposing of chemicals ensure that no two chemicals are mixed.

Safety advice concerning the use of the equipment described in this manual or any relevant hazard data sheets (where applicable) may be obtained from the Company address on the back cover, together with servicing and spares information.

# CONTENTS

Section	Page	Section	Page
<b>1 PREPARATION</b> .....	<b>2</b>	<b>4 MECHANICAL INSTALLATION</b> .....	<b>54</b>
1.1 Preparing the Recorder for First Use .....	2	4.1 Siting .....	54
1.2 Powering up the Recorder .....	4	4.2 Mounting .....	54
1.2.1 Recorder Status and Error Page .....	5	4.2.1 Wall-/Pipe-Mounting .....	55
		4.2.2 Panel Mounting .....	56
<b>2 OPERATION</b> .....	<b>6</b>	<b>5 ELECTRICAL INSTALLATION</b> .....	<b>57</b>
2.1 Display Screens and Operator Keys .....	6	5.1 Identifying the Input/Output Modules .....	58
2.2 Input Error Messages and Alarm Icons .....	7	5.2 Channel Connections .....	58
2.3 Operating Pages .....	8	5.2.1 Selecting the Analog Input Type(s) .....	59
2.3.1 Accessing the Operating Pages .....	8	5.2.2 Voltage and Current .....	60
2.3.2 Autoscroll .....	9	5.2.3 2-wire Transmitter Input .....	60
2.3.3 Input (Pen) Channel Display – Separate .....	10	5.2.4 Thermocouple .....	60
2.3.4 Input (Pen) Channel Display – Dual .....	11	5.2.5 Resistance Thermometer (RTD) .....	60
2.3.5 Input (Pen) Channel Display – Separate and Dual .....	11	5.2.6 Logic Inputs .....	60
2.3.6 Totalizer Display – Separate .....	12	5.2.7 Analog Output .....	60
2.3.7 Totalizer Display – Rate with Total .....	12	5.2.8 Relay Output .....	60
2.3.8 Totalizer Display – Total with Rate .....	13	5.3 Module Connections .....	61
2.3.9 Totalizer Display – Dual Total .....	13	5.3.1 Standard I/O or Analog + Relay (Module Types 1, 2 and 7) .....	61
2.3.10 Totalizer Display – Dual + Flow Rate ....	13	5.3.2 Four Relay Module (Module Type 3) ....	61
2.4 Totalizer Log .....	14	5.3.3 Eight Digital Inputs or Outputs (Module Types 4 and 5 respectively) ....	61
2.5 Totalizer Control .....	15	5.4 Power Supply Selection and AC Connections .....	62
2.6 Alarm Set Point Adjustment .....	16		
<b>3 CONFIGURATION</b> .....	<b>17</b>	<b>6 FAULT DIAGNOSIS</b> .....	<b>63</b>
3.1 Introduction .....	17	<b>7 SPARES AND ACCESSORIES</b> .....	<b>64</b>
3.2 Preparation for Configuration .....	17	<b>8 SPECIFICATION</b> .....	<b>65</b>
3.3 Configuration Level Security .....	17	<b>APPENDIX 1 – SIGNAL SOURCES</b> .....	<b>68</b>
3.4 Common Configuration .....	18	<b>INDEX</b> .....	<b>69</b>
3.5 Channels Configuration .....	22	<b>INSTALLATION RECORD</b> .....	<b>71</b>
3.6 Alarms Configuration .....	29		
3.7 Totalizer Configuration .....	33		
3.8 Relay Configuration .....	40		
3.9 Digital Input and Output Configuration .....	41		
3.10 Analog Output Configuration .....	43		
3.11 Logic Equation Configuration .....	45		
3.12 System Clock Configuration .....	48		
3.13 Pen Function .....	49		
3.14 Calibration .....	51		
3.15 Backing Up and Restoring Configurations .....	52		
3.15.1 Backing Up a Configuration .....	52		
3.15.2 Restoring a Configuration .....	53		

# 1 PREPARATION

## 1.1 Preparing the Recorder for First Use – Figs. 1.1 and 1.2

- a) Install the recorder – see Section 4.
- b) Connect the recorder – see Section 5.



**Warning.** Ensure all connections are made correctly, especially to the earth (ground) stud – see Section 5.4.

- c) Switch on the power supply to the recorder.

**Note.** On power-up, the pen arm(s) is (are) moved to an off-chart position for automatic referencing. Pen chatter may occur on the pen(s) nearest the reference position. **This is a normal function of the recorder.**

- d) Fit the pen capsule(s) – see Fig. 1.1.

**Note.** Ensure the correct colored capsule is fitted to the appropriate pen arm. Each pen arm is identified by a colored band – see Fig. 1.1.

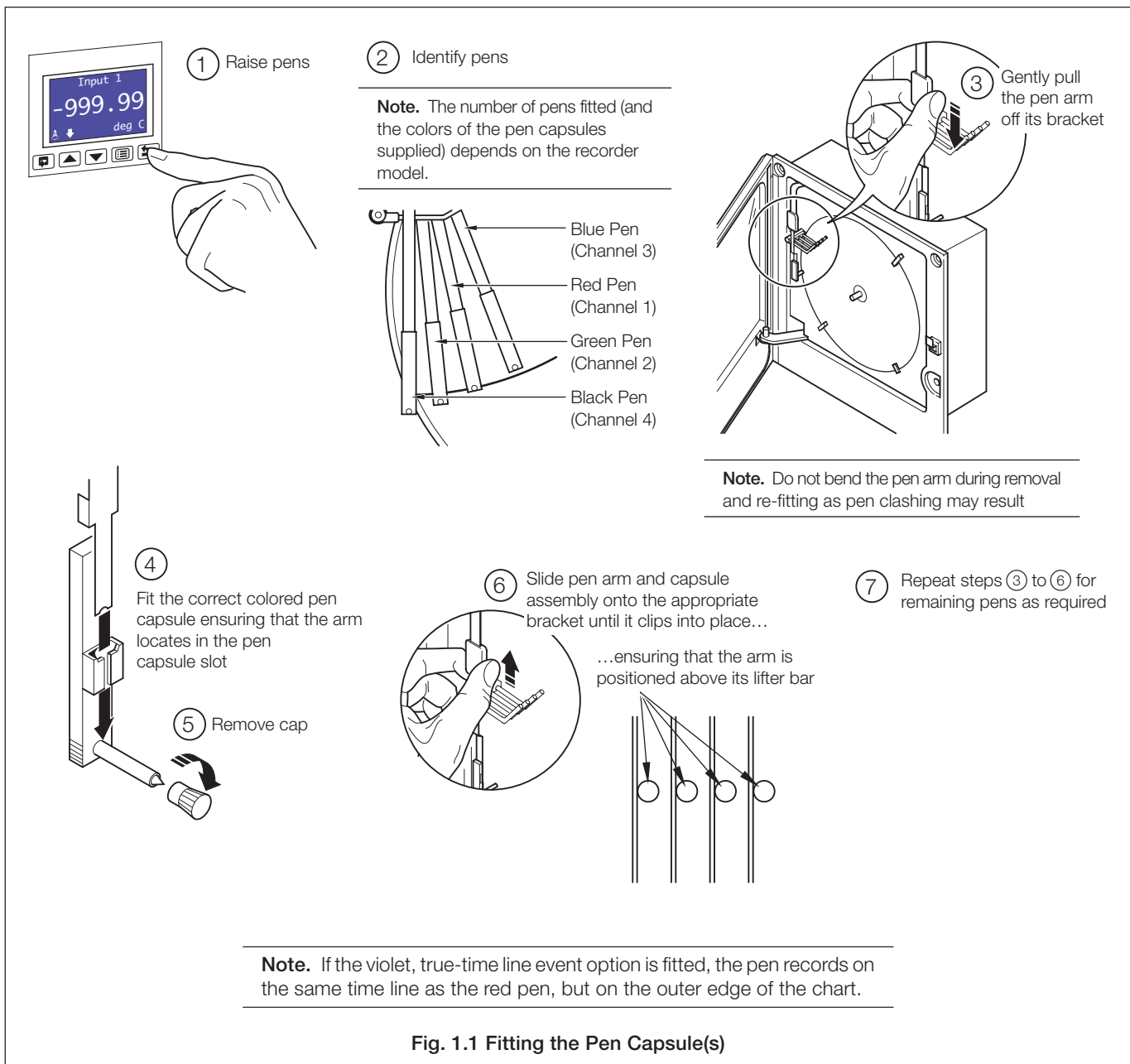

**Fig. 1.1 Fitting the Pen Capsule(s)**

## ...1.1 Preparing the Recorder for First Use – Figs. 1.1 and 1.2

e) Fit a chart – see Fig. 1.2.

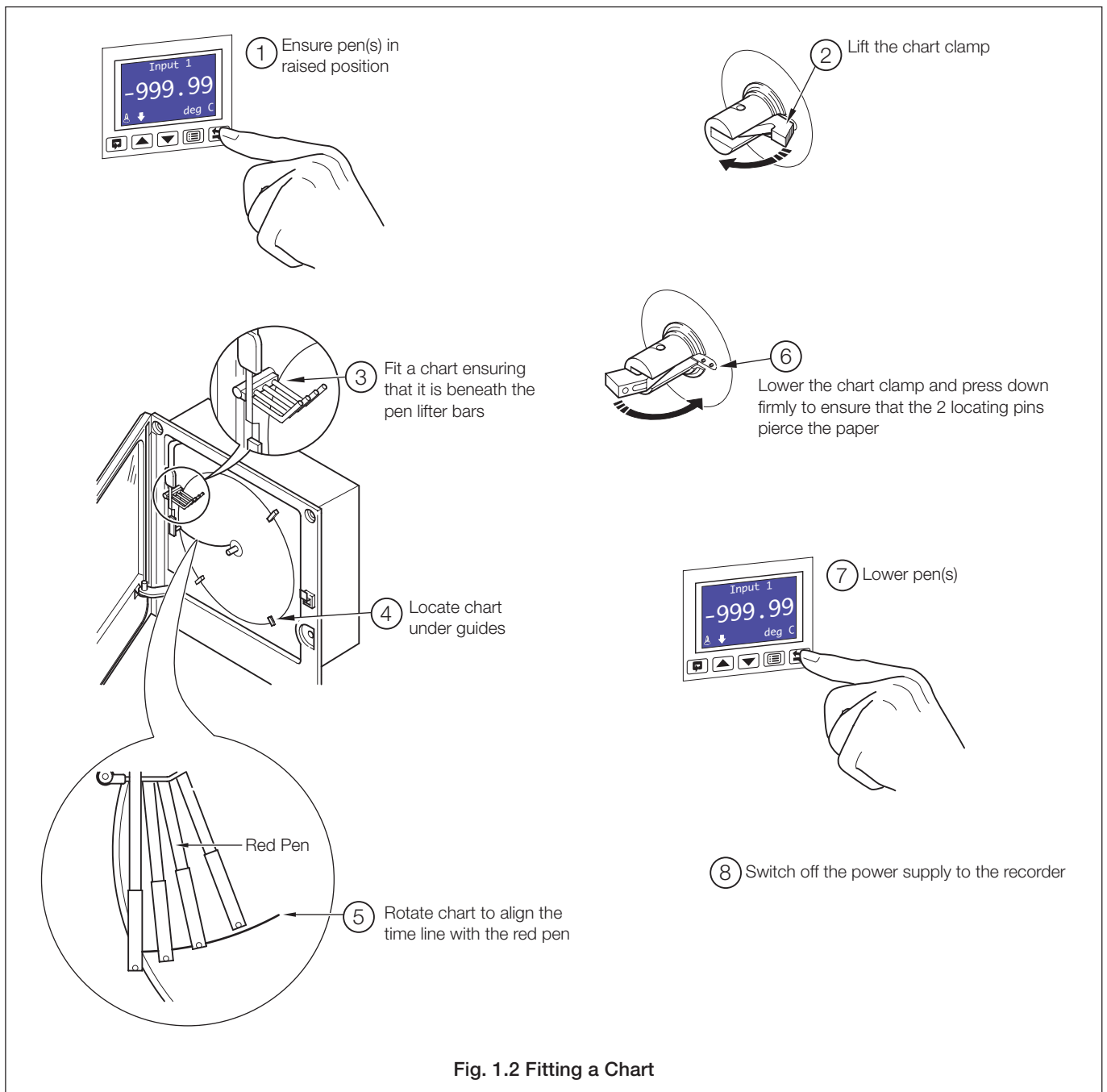

**1.2 Powering up the Recorder – Fig. 1.3**

- a) Switch on the supply to the recorder, any power-operated control circuits and the input signals. Wait for the pens to settle.
- b) The start-up self-test sequence shown in Fig. 1.3 is shown on display screen 1 when the power supply is first switched on.

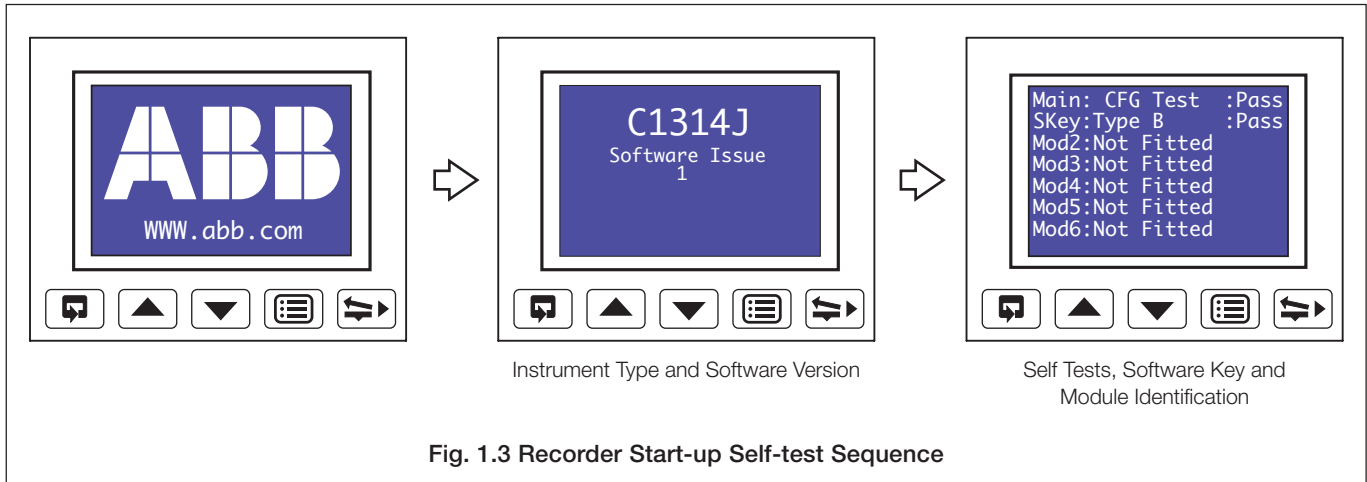

1.2.1 Recorder Status and Error Page – Fig. 1.4

If any of the start-up self-tests (see Fig. 1.3) fail, the error message 'Fail' is displayed. Refer to Fig. 1.4 for possible cause and remedial action information.

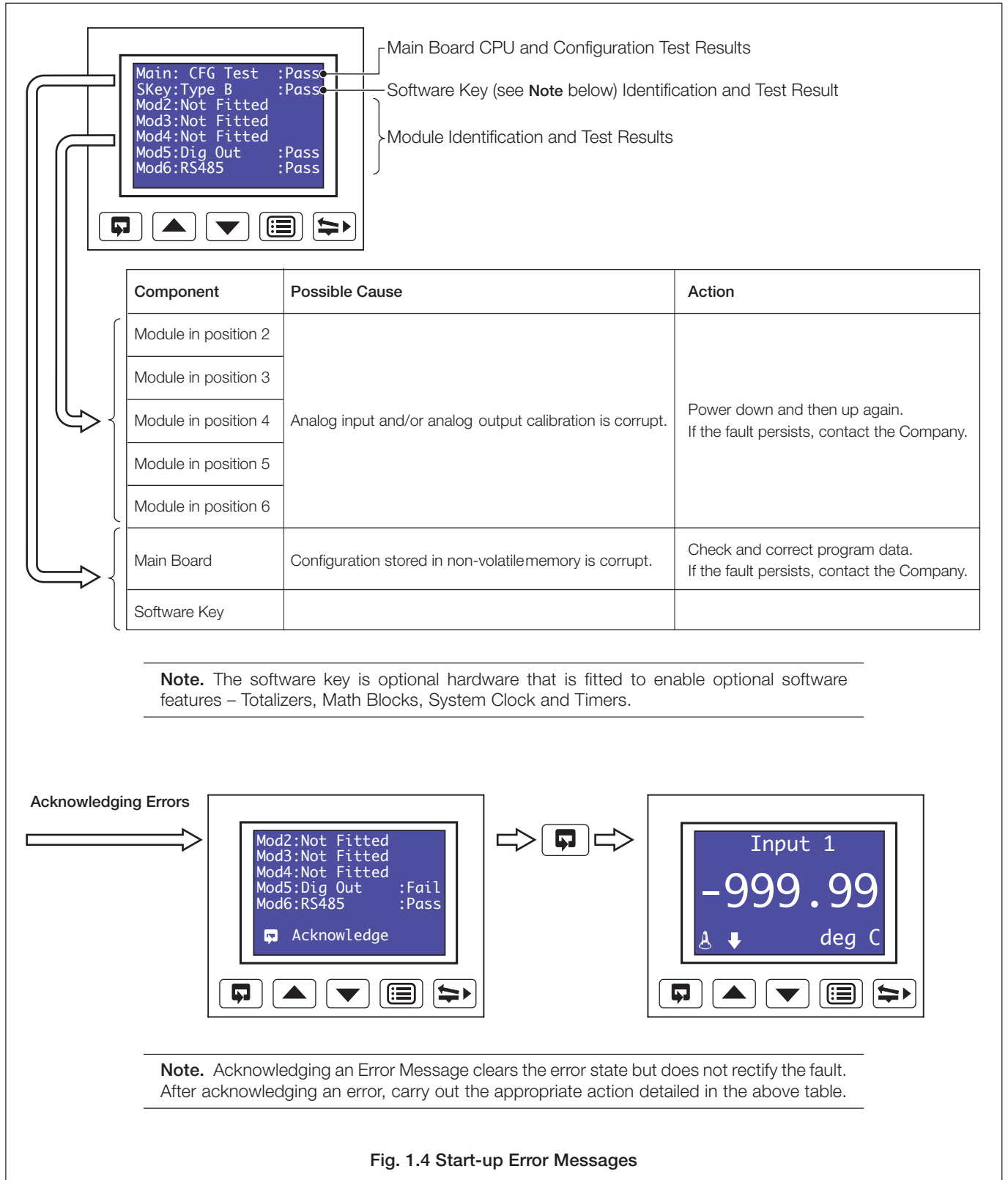

Fig. 1.4 Start-up Error Messages

## 2 OPERATION

### 2.1 Display Screens and Operator Keys – Fig. 2.1

Up to two faceplates are fitted to the front of the recorder, each comprising a display screen and associated operator keys – see Fig. 2.1.

Each high resolution, dot matrix display screen shows the operating and programming information for up to two input channels in a variety of formats.

Alarm states are indicated by icons in the lower left corner of the display screen(s) – see Fig. 2.3.

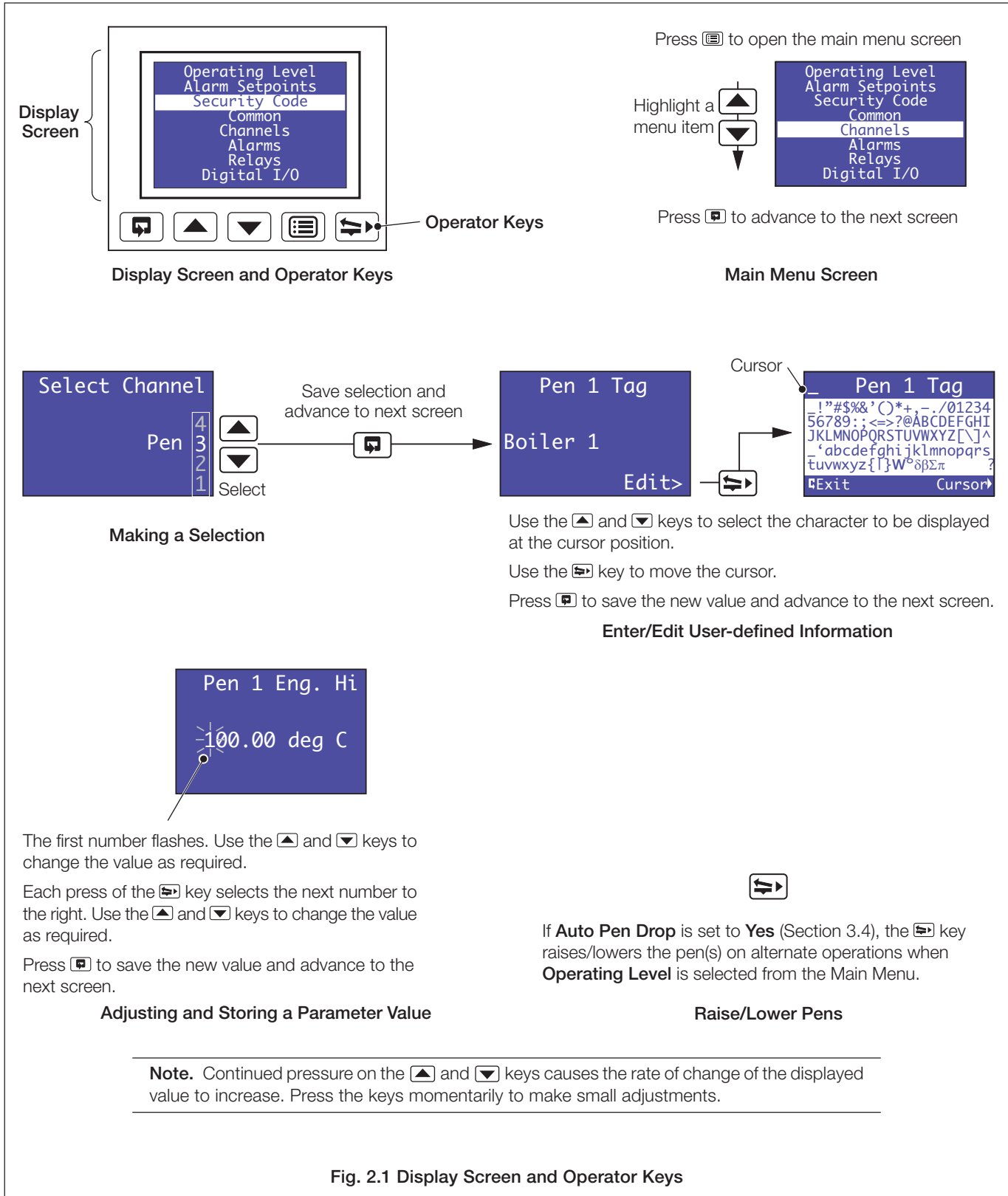

The recorder has dedicated *Operating Pages* in the **Operating Level** – see Sections 2.3 to 2.6. These pages display the process measurements and are not affected by the security system which inhibits access to the **Configuration Pages** – see Section 3.3.

2.2 Input Error Messages and Alarm Icons – Figs. 2.2 and 2.3

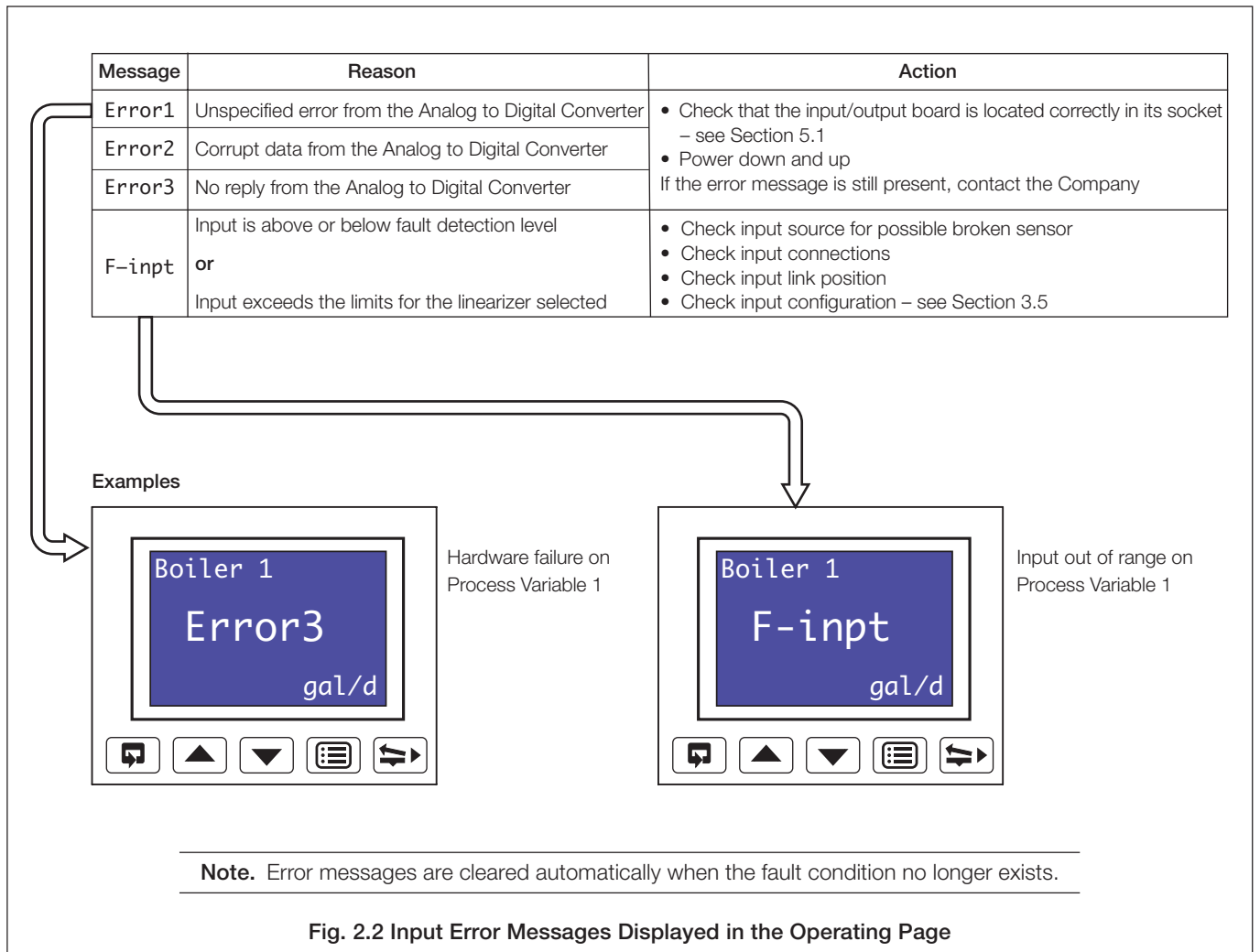

Fig. 2.2 Input Error Messages Displayed in the Operating Page

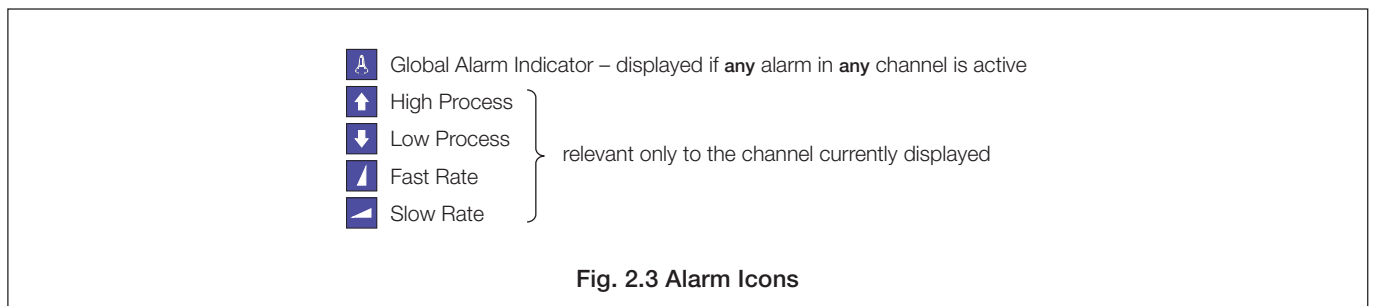



Fig. 2.3 Alarm Icons

## 2.3 Operating Pages

### Overview.

- The following information is displayed in the *Operating Pages*:
  - Input (pen) channel readings
  - System time/date (if any one of the Totalizer, Math or Timers software options are enabled by installation of the appropriate software key)
  - Totalizer readings (if the totalizer software option is enabled by installation of the appropriate software key)
  - Totalizer log (if the totalizer software option is enabled by installation of the appropriate software key)
  - Totalizer control (if the totalizer software option is enabled and **and Totalizer Reset** is set to **YES** – see Section 3.4.)
  - Alarm set points (if **Alarm Adjust** is set to **Yes** – see Section 3.4)
- The Input (pen) channel and totalizer displays are configured separately (see **Pen Ch Display** and **Totals Display** in Section 3.4) and each can be displayed in one of several ways. Input channel information can be displayed without totalizer information and vice-versa.
- Input channel 1 and 2 information and system time/date is shown on display screen 1.
- If the recorder is fitted with the optional second faceplate:
  - Input channel 3 and 4 information, together with system time/date is shown on display screen 2
  - Totalizer logs, totalizer control and alarm set point adjustment for pens 3 and 4 and associated totalizers are accessed from the menu shown on display screen 2 when the  key is pressed on faceplate 2.
- Totalizer information is shown on the same display screen as the pen to which the totalizer is assigned.
- All channel and totalizer configuration is done using faceplate 1.

### 2.3.1 Accessing the Operating Pages

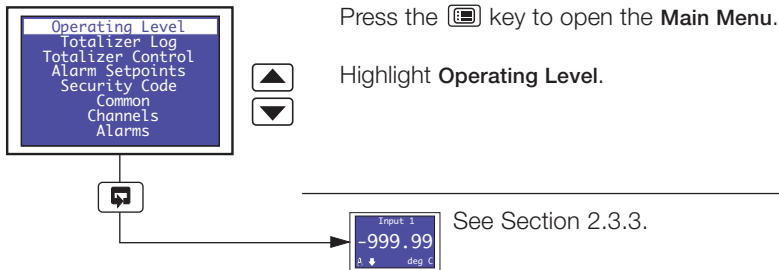

## 2.3.2 Autoscroll

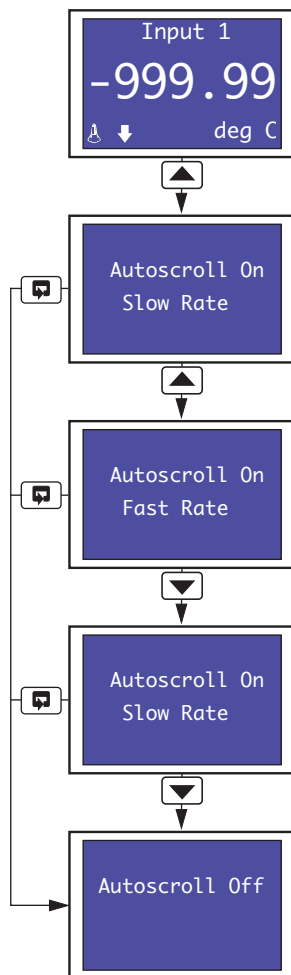
**Autoscroll**

When **Autoscroll** is set to **On**, each *Operating Page* screen is displayed in turn for a period of time determined by the rate selected:

**Slow Rate** – each screen is displayed in turn for 10 seconds

**Fast Rate** – each screen is displayed in turn for 5 seconds

Press the  key from any *Operating Page* screen to initiate Autoscroll in Slow Rate mode.

Press the  key again to switch to Fast Rate mode.

When in Fast Rate mode, press the  key to switch to Slow Rate mode.

When in Slow Rate mode, press the  key to switch Autoscroll off.

Press the  key at any time to switch Autoscroll off.

### 2.3.3 Input (Pen) Channel Display – Separate

The following screens are displayed only if **Pen Ch Display** is set to **Separate** – see Section 3.4.

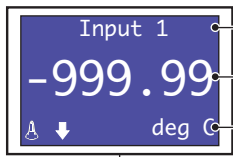

#### Input Channel 1 (Pen 1)

- Channel tag.
- Measured value.
- Alarm icons and measured value units.

**Note.** If **Pen 1 Source** is set to **None** (Section 3.13), only a measured value of 0 is displayed.

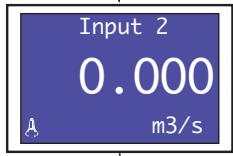

#### Input Channel 2 (Pen 2)

**Note.** If **Pen 2 Source** is set to **None** (Section 3.13), only a measured value of 0 is displayed.



Totalizer, Math or Timers software options not enabled by installation of the appropriate software key– return to top of page.



Totalizer software option enabled by installation of the appropriate software key **and** **Totals Display** not set to **Off** (Section 3.4) – see Sections 2.3.6 to 2.3.10.



Totalizer software option enabled by installation of the appropriate software key **and** **Totals Display** set to **Off** (Section 3.4) – continued below.

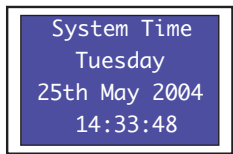

#### System Time/Date Display

##### Notes.

- Available only if any one of the Totalizer, Math or Timers software options are enabled by installation of the appropriate software key.
- If **Pen Ch Display** **and** **Totals Display** are set to **Off** (Section 3.4) **and** any of the above software options are enabled, the System Time Display is the only *Operating Page* screen available.



Return to top of page.

### 2.3.4 Input (Pen) Channel Display – Dual

The following screens are displayed only if **Pen Ch Display** is set to **Dual** – see Section 3.4.

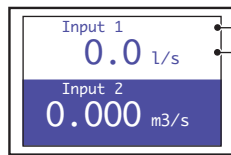

#### Input Channels 1 and 2 (Pens 1 and 2)

Channel tag.  
Measured value and units.

**Note.** If **Pen X Source** (where X is the pen number) is set to **None** (Section 3.13), only a measured value of 0 is displayed for that channel.



Totalizer, Math or Timers software options not enabled by installation of the appropriate software key – return to top of page.



Totalizer software option enabled by installation of the appropriate software key **and** **Totals Display** not set to **Off** (Section 3.4) – see Sections 2.3.6 to 2.3.10.



Totalizer software option enabled by installation of the appropriate software key **and** **Totals Display** set to **Off** (Section 3.4) – see Section 2.3.3.

### 2.3.5 Input (Pen) Channel Display – Separate and Dual

The following screens are displayed only if **Pen Ch Display** is set to **Separate & Dual** – see Section 3.4.

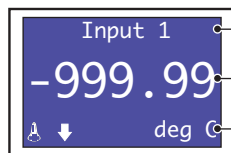

#### Input Channel 1 (Pen 1)

Channel tag.  
Measured value.  
Alarm icons and measured value units.

**Note.** If **Pen 1 Source** is set to **None** (Section 3.13), only a measured value of 0 is displayed.

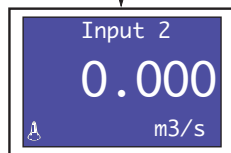

#### Input Channel 2 (Pen 2)

**Note.** If **Pen 2 Source** is set to **None** (Section 3.13), only a measured value of 0 is displayed.

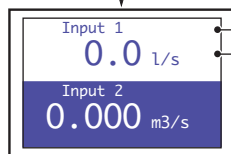

#### Input Channels 1 and 2 (Pens 1 and 2)

Channel tag.  
Measured value and units.

**Note.** If **Pen X Source** (where X is the pen number) is set to **None** (Section 3.13), only a measured value of 0 is displayed for that channel.



Totalizer, Math or Timers software options not enabled by installation of the appropriate software key – return to top of page.



Totalizer software option enabled by installation of the appropriate software key **and** **Totals Display** not set to **Off** (Section 3.4) – see Sections 2.3.6 to 2.3.10.



Totalizer software option enabled by installation of the appropriate software key **and** **Totals Display** set to **Off** (Section 3.4) – see Section 2.3.3.

### 2.3.6 Totalizer Display – Separate

The following screens are displayed only if **Totals Display** is set to **Separate** (Section 3.4) **and Tot X Source** (where X is the totalizer number) is set to anything other than **None** – see Section 3.7.

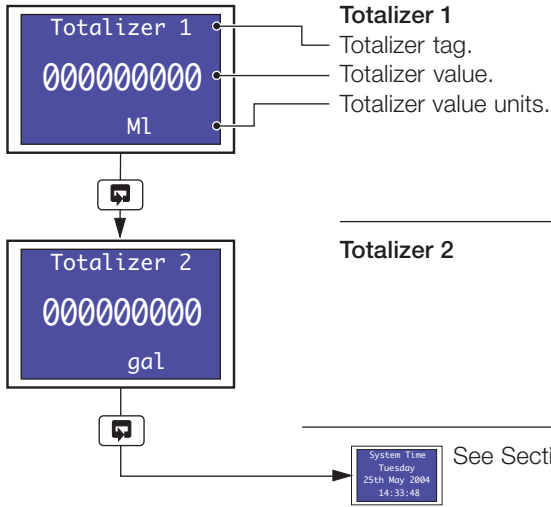

### 2.3.7 Totalizer Display – Rate with Total

The following screens are displayed only if **Totals Display** is set to **Rate with Total** (Section 3.4) **and Tot X Source** (where X is the totalizer number) is set to anything other than **None** – see Section 3.7.

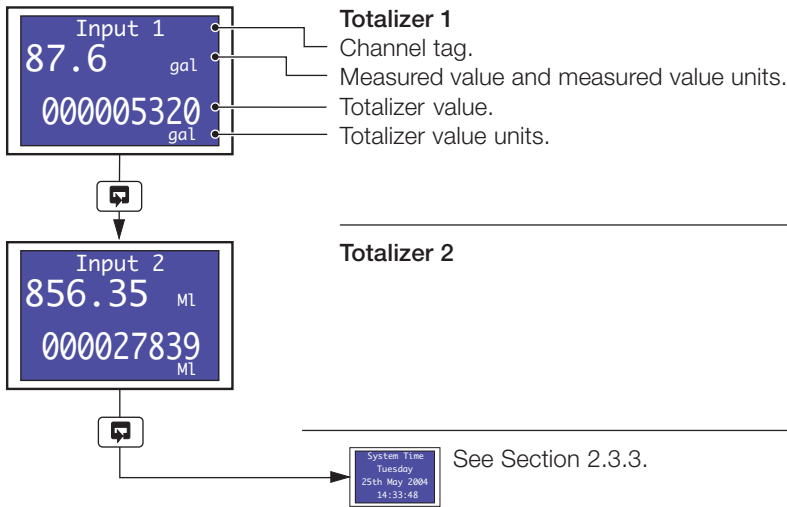

### 2.3.8 Totalizer Display – Total with Rate

The following screens are displayed only if **Totals Display** is set to **Total with Rate** (Section 3.4) **and** **Tot X Source** (where X is the totalizer number) is set to anything other than **None** – see Section 3.7.

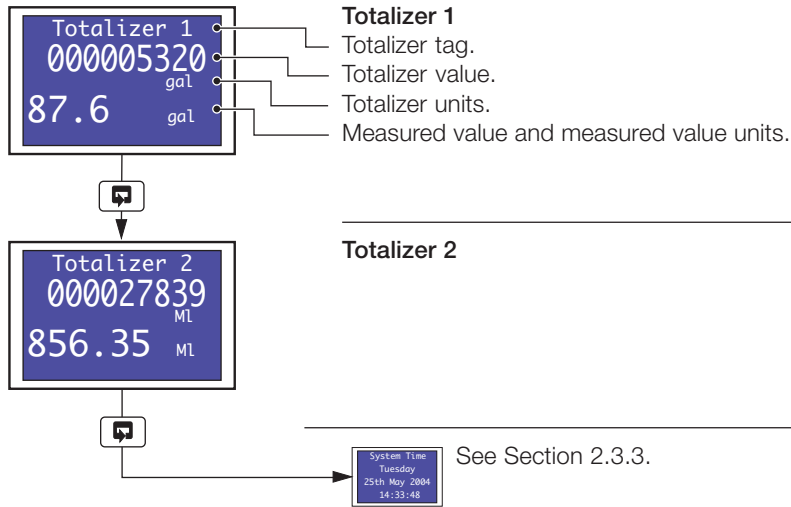

### 2.3.9 Totalizer Display – Dual Total

The following screen is displayed only if **Totals Display** is set to **Dual Total** (Section 3.4) **and** **Tot X Source** (where X is the totalizer number) is set to anything other than **None** – see Section 3.7.

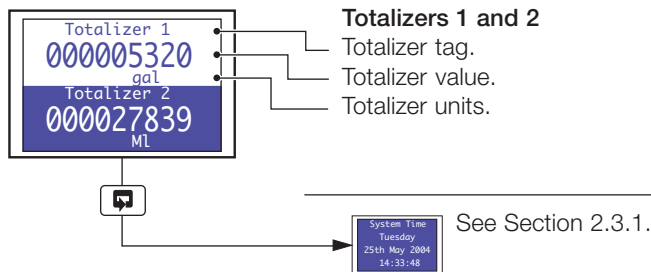

### 2.3.10 Totalizer Display – Dual + Flow Rate

The following screen is displayed only if **Totals Display** is set to **Dual + Flow Rate** (Section 3.4) **and** **Tot X Source** (where X is the totalizer number) is set to anything other than **None** – see Section 3.7.

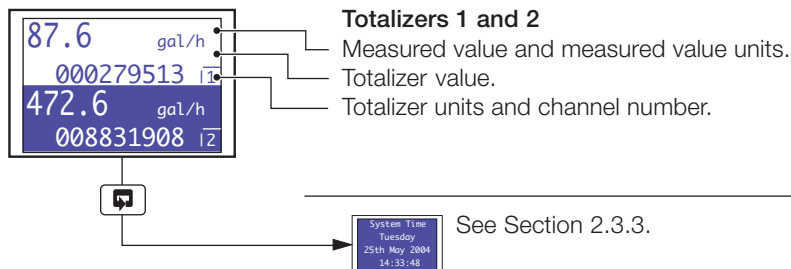

## 2.4 Totalizer Log

### Notes.

- The totalizer log is available only if the totalizer software option is enabled by installation of the appropriate software key.
- The recorder can store up to 21 log entries for each enabled totalizer. When the maximum number of entries has been reached, the oldest data is overwritten by the newest.
- A new log entry is created for each totalizer at the interval selected in the **Tot X Log Enable** parameter (where **X** is the totalizer number) – see Section 3.7.



Press the  key to open the **Main Menu**.

Highlight **Totalizer Log**.

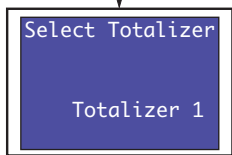

### Select Totalizer

Select the totalizer log to display.

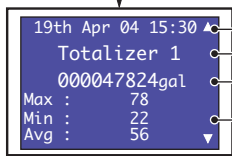

### Totalizer Log

The first log displayed for the selected totalizer is the most recent. Use the  key to display each log in descending date order.

Date and time.

Totalizer tag.

Current value and units.

Maximum, minimum and average values.

**Note.** If no log entries exist **Log is empty** is shown on the display screen.



Return to top of page.

## 2.5 Totalizer Control

**Note.** Totalizer control is available only if the totalizer software option is enabled by installation of the appropriate software key **and** **Totalizer Reset** is set to **YES** – see Section 3.4.

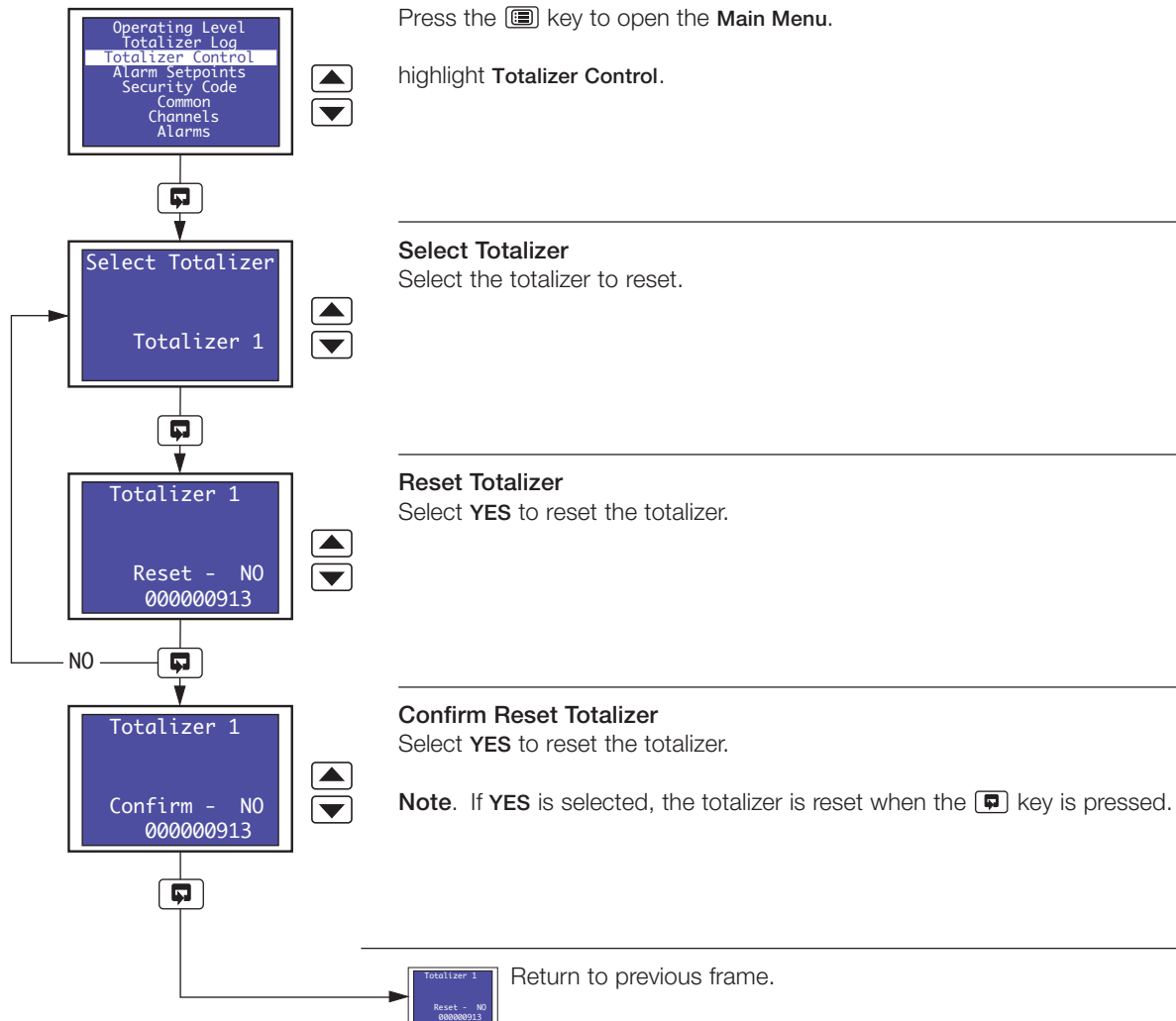

## 2.6 Alarm Set Point Adjustment

**Note.** Alarm set point adjustment is available only if **Alarm Adjust** is set to **YES** – see Section 3.4.



Press the  key to open the **Main Menu**.

Highlight **Alarm Adjust**.

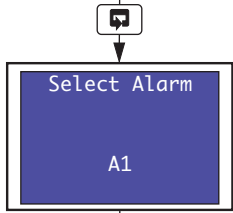

**Select Alarm**  
Select the alarm to adjust.

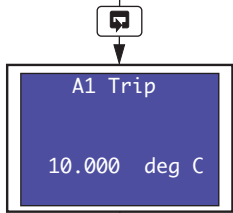

**Alarm Set Point**  
Adjust the alarm set point.

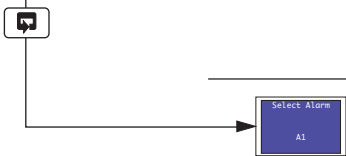

Return to top of page.

## 3 CONFIGURATION

### 3.1 Introduction

The configuration procedures are used to make changes to the operating parameter values and for scale adjustment. Configuration of all channels is performed from faceplate 1.



The configuration settings can be backed up to a PC and restored to the recorder as required – see Section 3.15.

An overview of the **Configuration Pages** is on the rear cover fold-out.

When changing the input type, it may be necessary to reposition the input selector links accordingly – see Section 5.2.1.

### 3.2 Preparation for Configuration

#### Notes.

- Isolate any external alarm/control circuits if inadvertent operation during configuration is undesirable.
- The recorder responds instantly to parameter changes. These are saved automatically when either the  or  key is pressed.
- The display screen of faceplate 2 (if fitted) shows **Configuration Mode** when the configuration pages are accessed by scrolling past **Security Code** in the Main Menu on the display screen of faceplate 1.

### 3.3 Configuration Level Security

Unauthorised access to the configuration pages is prevented by the use of a security code.

The security code, set to '0' when the recorder is despatched, can be set to any value from 0 to 9999 – see **Configure Password** in Section 3.4. When set to anything other than '0', access to all configuration menus (i.e. all menus below **Security Code**) is prevented. Enter the correct code to enable access to the configuration menus.

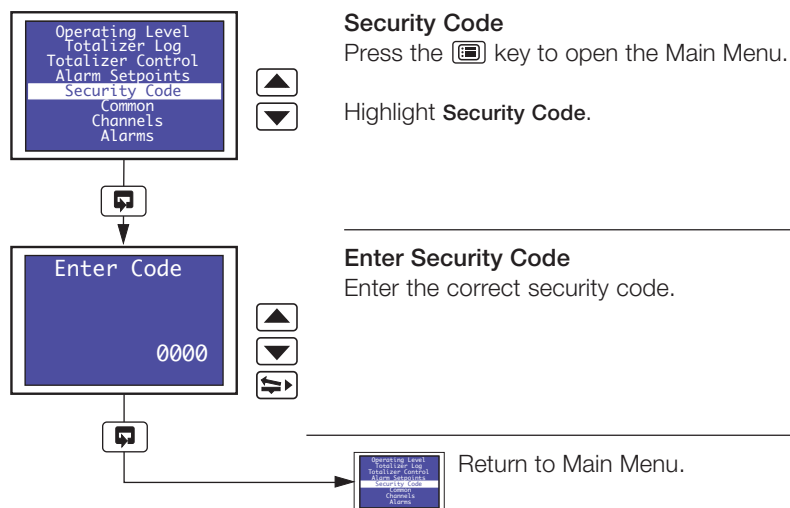

3.4 Common Configuration



**Common Configuration**

Press the  key to open the **Main Menu**.

Highlight **Common**.

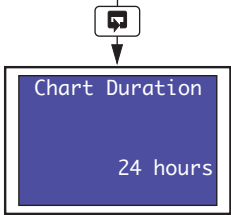

**Chart Duration**

Select the chart duration required per revolution of the chart:  
between 1 and 167 hours in 1 hour increments  
between 7 and 32 days in 1 day increments

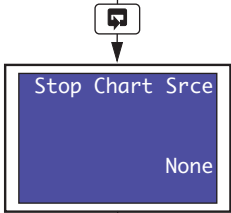

**Stop Chart Source**

Select the source required for stopping the chart.  
Refer to Appendix 1 for description of sources.

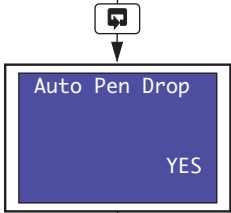

**Auto Pen Drop**

Select **YES** to enable the pen(s) to drop automatically onto the chart 5 minutes after they are lifted.  
If **NO** is selected, the pen(s) remain lifted until they are dropped manually by the operator.

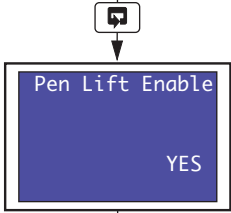

**Pen Lift Enable**

Select **YES** to enable the pen(s) to be raised and lowered using the pen lift key ().

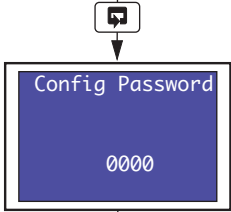

**Configure Password**

Select a code between 1 and 9999.



Continued on next page.

## ...3.4 Common Configuration

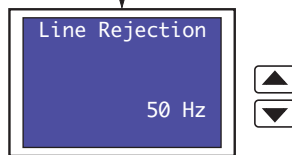
**Line Rejection**

Select the frequency of the mains supply to ensure maximum noise rejection on analog inputs.

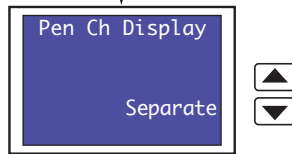
**Pen Channel Display**

Select the style of input (pen) channel display required in the *Operating Page* – see Sections 2.3.3 to 2.3.5.

**Off**

- input channel information is not displayed in the *Operating Page*

**Separate**

- input channel information for channels 1 and 2 is shown separately on display screen 1. Input channel information for channels 3 and 4 (3 and 4 pen recorders only) is shown separately on display screen 2 – see Section 2.3.3

**Dual**

- input channel information for channels 1 and 2 is shown simultaneously on display screen 1. Input channel information for channels 3 and 4 (3 and 4 pen recorders only) is shown simultaneously on display screen 2 – see Section 2.3.4

**Separate & Dual**

- input channel information for channels 1 and 2 is first shown separately, then simultaneously on display screen 1. Input channel information for channels 3 and 4 (3 and 4 pen recorders only) is first shown separately, then simultaneously on display screen 2 – see Section 2.3.5



Continued on next page.

...3.4 Common Configuration

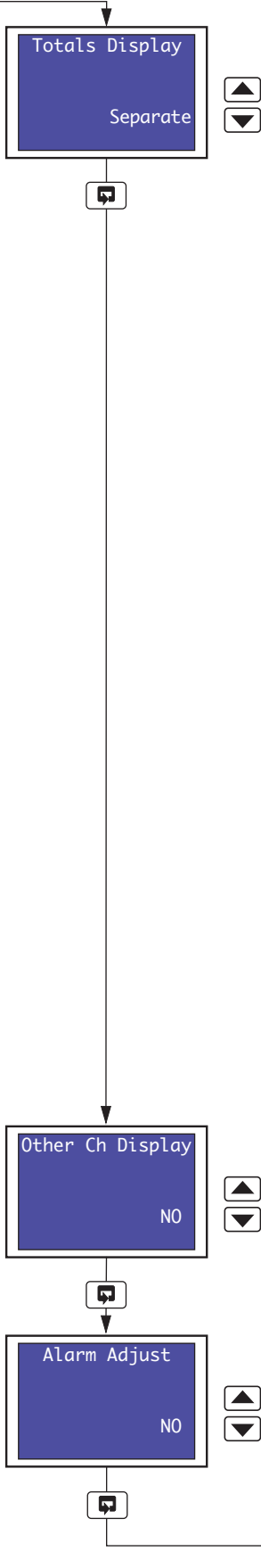

**Totalizers Display**

**Note.** Displayed only if the totalizer software option is enabled by installation of the appropriate software key.

Select the style of totalizer display required in the *Operating Page* – see Sections 2.3.6 to 2.3.10.

- Off** – totalizer values are not displayed in the *Operating Page*
- Separate** – totalizer values for totalizers assigned to channels 1 and 2 are shown separately on display screen 1. Totalizer values for totalizers assigned to channels 3 and 4 (3 and 4 pen recorders only) are shown separately on display screen 2 – see Section 2.3.6
- Rate with Total** – totalizer values for totalizers assigned to channels 1 and 2, together with the current measured values for channels 1 and 2, are shown separately on display screen 1. Totalizer values for totalizers assigned to channels 3 and 4 (3 and 4 pen recorders only), together with the current measured values for channels 3 and 4, are shown separately on display screen 2 – see Section 2.3.7
- Total with Rate** – the current measured values for channels 1 and 2, together with totalizer values for totalizers assigned to channels 1 and 2, are shown separately on display screen 1. The current measured values for channels 3 and 4 (3 and 4 pen recorders only), together with totalizer values for totalizers assigned to channels 3 and 4, are shown separately on display screen 2 – see Section 2.3.8
- Dual Total** – totalizer values for totalizers assigned to channels 1 and 2 are shown simultaneously on display screen 1. Totalizer values for totalizers assigned to channels 3 and 4 (3 and 4 pen recorders only) are shown simultaneously on display screen 2 – see Section 2.3.9
- Dual + Flow Rate** – totalizer values for totalizers assigned to channels 1 and 2, together with the current measured values for channels 1 and 2, are shown simultaneously on display screen 1. Totalizer values for totalizers assigned to channels 3 and 4 (3 and 4 pen recorders only), together with the current measured values for channels 3 and 4, are shown simultaneously on display screen 2 – see Section 2.3.10

**Note.** Do not select **Dual + Flow Rate** if a totalizer is not assigned to each of the channels to be displayed – see Section 3.7.

**Other Channels Display**

Select **YES** to display information for input channels not assigned to pens.

**Alarm Adjust**

Select **YES** to enable alarm set point adjustment in the *Operating Page* – see Section 2.6.

Continued on next page.

## ...3.4 Common Configuration

Totalizer Reset  
NO

**Totalizer Reset**

**Note.** Displayed only if the totalizer software option is enabled by installation of the appropriate software key.

Select **YES** to enable the totalizers to be reset in the *Operating Page* – see Section 2.5.

Contrast 1  
100%

**Contrast 1**

Select the required contrast setting for display screen 1, between 0 and 100%.

Contrast 2  
100%

**Contrast 2**

**Note.** Shown only if faceplate 2 is fitted.

Select the required contrast setting for display screen 2, between 0 and 100%.

Brightness 1  
100%

**Brightness 1**

Select the required brightness setting for display screen 1, between 0 and 100%.

Brightness 2  
100%

**Brightness 2**

**Note.** Shown only if faceplate 2 is fitted.

Select the required brightness setting for display screen 2, between 0 and 100%.

Chart Duration  
24 hours

Return to top of page.

3.5 Channels Configuration

Overview.

- **Universal inputs** – mV, mA, V, THC, RTD and resistance.
- **Internal cold junction compensation.**
- **Linearization** – enables use of non-linearizing temperature transmitters or any electrical input.
- **Programmable fault levels and actions.**
- **Digital filter** – reduces the effect of noise on inputs.

Example A – setting up:

- a current input of 4 to 20mA
- displaying a range of 0 to 200psi
- a fault detection level 10% above 200psi (engineering/display range) and 10% below 0psi (engineering/display range)
- in the event of a fault being detected and/or the fault detection level being exceeded, the process variable is driven downscale.

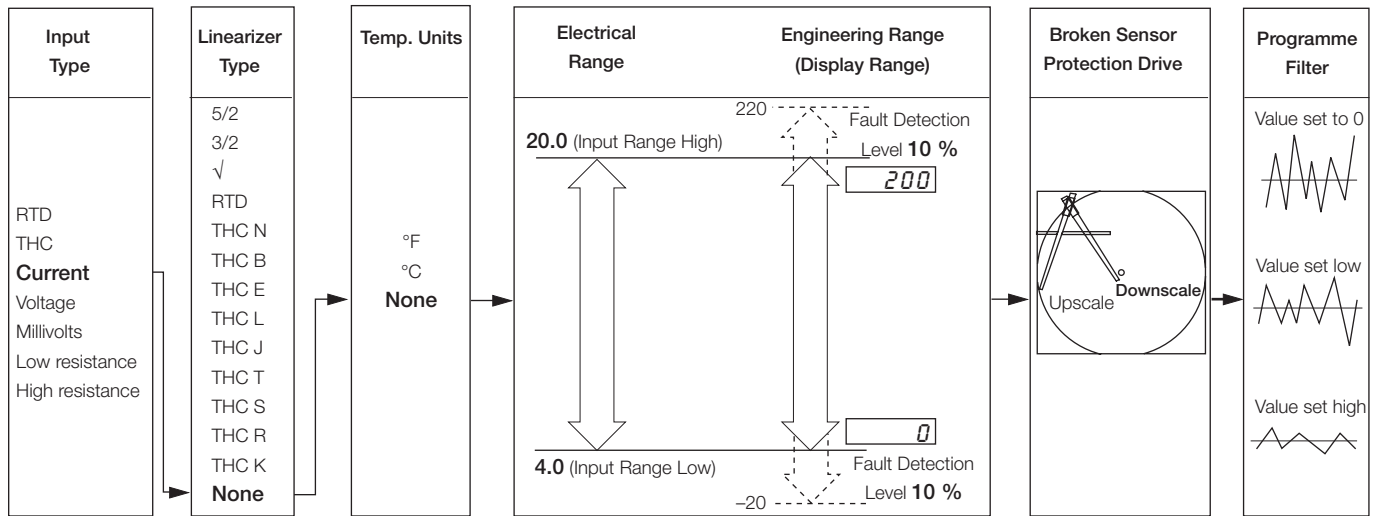

Example B – setting up:

- a Type K thermocouple
- displaying temperature in °F
- displaying a range of 0 to 2000°F
- a fault detection level 10% above 2000°F (engineering/display range) and 10% below 0°F (engineering/display range)
- in the event of a fault being detected and/or the fault detection level being exceeded, the process variable is driven upscale.

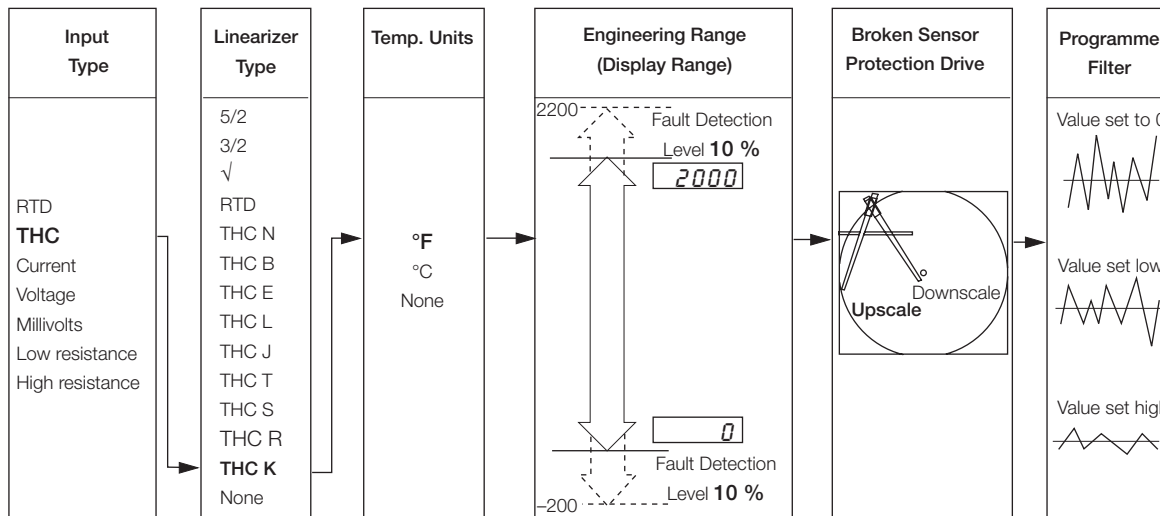

...3.5 Channels Configuration

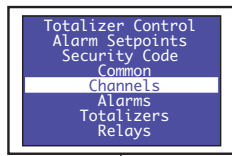

**Channels Configuration**

Press the  key to open the **Main Menu**.

Highlight **Channels**.

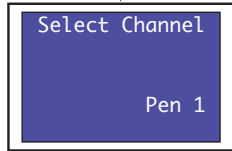

**Select Channel**

Select the channel to configure.

**Note.** If **Pen X Function** or **Pen X Source** (where **X** is the pen number) is set to **Off** or **None** respectively (Section 3.13), that pen cannot be selected.



**Pen X Function** set to **Trend** (Section 3.13) – continued on next page.



**Pen X Function** set to **Event** (Section 3.13) – continued on page 28.

...3.5 Channels Configuration

Pen X Function  
set to Trend  
(Section 3.13)

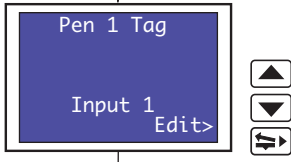

**Channel Tag**

Press the key to open the Edit screen.

Use the , and keys to enter the channel tag required – see Fig. 2.1 on page 6.

Press the key to close the edit screen and save the tag.

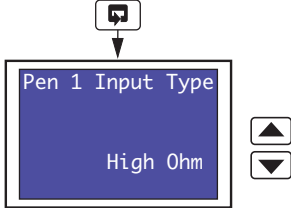

**Channel Input Type**

Select the required channel input type.

- None – None
- Millivolt – Millivolt ( $\leq 150\text{mV}$ )
- Milliamp – Current
- High Ohm – High resistance ( $>750\Omega$ )
- Low Ohm – Low resistance ( $\leq 750\Omega$ )
- Volts – Voltage
- Thermocouple – Thermocouple
- Rtd – Resistance thermometer

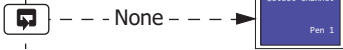

Return to top of page.

- Millivolt
- Milliamp
- High Ohm
- Low Ohm
- Volts
- Thermocouple
- Rtd

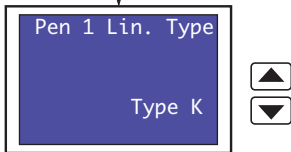

**Linearizer Type**

Select the required linearizer type.

- None – No linearizer
- Type K – Type K thermocouple
- Type R – Type R thermocouple
- Type S – Type S thermocouple
- Type T – Type T thermocouple
- Type J – Type J thermocouple
- Type E – Type E thermocouple
- Type N – Type N thermocouple
- Type B – Type B thermocouple
- Rtd – Resistance thermometer
- Square Root – Square root
- 3/2 –  $X^{3/2}$
- 5/2 –  $X^{5/2}$  } Open channel flow applications



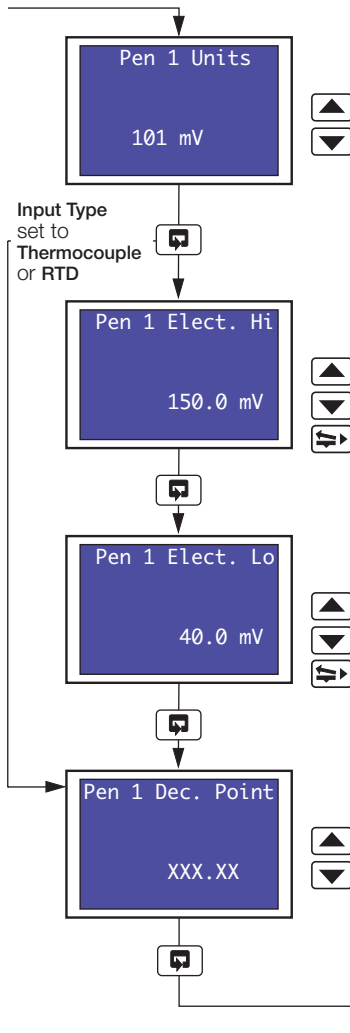

Continued on next page.

...3.5 Channels Configuration



**Channel Units**

Select any one of the 112 units pre-programmed into the recorder or select **113 Custom** and use the ,  and  keys to enter the units required – see Fig. 2.1 on page 6.

**Electrical Input Range High**

Set the maximum electrical input value required, within the limits shown in the Table 3.1.

**Electrical Input Range Low**

Set the minimum electrical input value required, within the limits shown in the Table 3.1.

**Decimal Point**

Select the decimal point position for the engineering and chart ranges.

Continued on next page.

Input Type	Electrical Range Low	Electrical Range High	Minimum Span (Low to High)
Millivolts	0	150	5.0
Milliamps	0	50	1.0
Resistance (High)	0	9999	400
Resistance (Low)	0	750	20
Volts	0	5	0.1

Table 3.1 Limits of Electrical Ranges

### ...3 CONFIGURATION

#### ...3.5 Channels Configuration

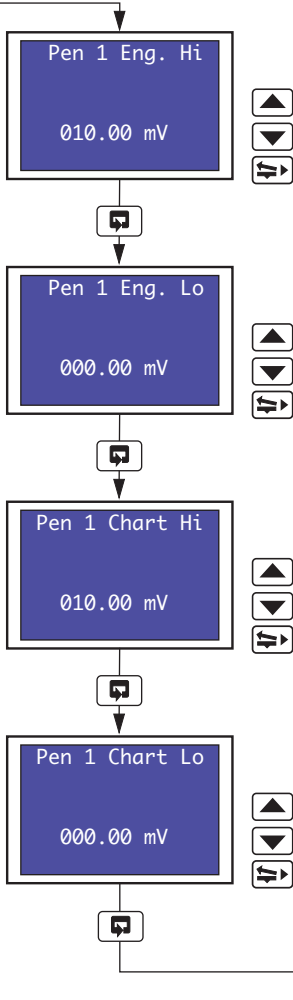

#### Engineering Range High

Set the maximum engineering value required, within the limits shown in Table 3.2.

#### Engineering Range Low

Set the minimum engineering value required, within the limits shown in Table 3.2.

#### Chart Range High

Set the maximum value, in engineering units, required on the chart.

**Note.** If the **Engineering Range High** setting is changed, the **Chart Range High** setting is reset automatically to the same value.

#### Chart Range Low

Set the minimum value, in engineering units, required on the chart.

**Note.** If the **Engineering Range Low** setting is changed, the **Chart Range Low** setting is reset automatically to the same value.

Continued on next page.

Linearizer Type	Degrees Celsius			Degrees Fahrenheit		
	Minimum	Maximum	Minimum Span	Minimum	Maximum	Minimum Span
Type K	-100	1300	65	-148	2372	117
Types R & S	-18	1700	320	0	3092	576
Type T	-250	300	60	-418	572	108
Type J	-100	900	50	-148	1652	90
Type E	-100	900	45	-148	1652	81
Type N	-200	1300	90	-328	2372	162
Type B	-18	1800	710	0	3272	1278
Rtd	-200	600	25	-328	1112	45

Performance accuracy is not guaranteed below 400°C (725°F) for types B, R and S thermocouples.

Minimum span below zero for Type T thermocouples is 70°C (126°F).

Minimum span below zero for Type N thermocouples is 105°C (189°F).

THC standard DIN 4730 IEC 584.

RTD standard DIN 43760 IEC 751.

Linearizer Type	Engineering Range High and Low	
	Minimum	Maximum
Square Root	-9999	9999
3/2		
5/2		
None		

Table 3.2 Limits of Engineering Ranges

## ...3.5 Channels Configuration

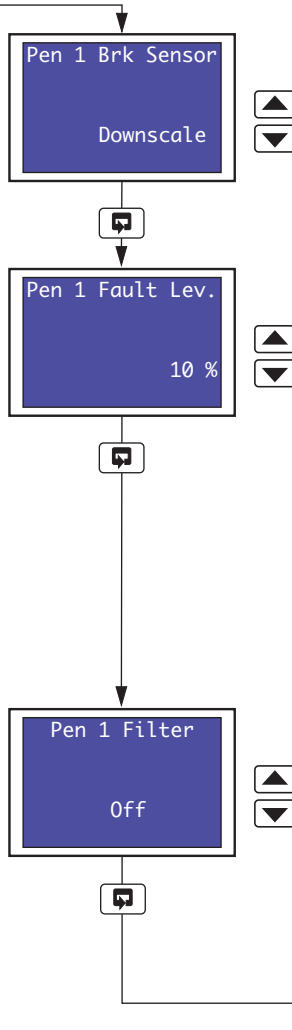
**Broken Sensor Protection Drive**

In the event of an input failure, the process variable is driven in the direction selected:

- Downscale** – Process variable driven below zero
- None** – Process variable driven in direction of failure
- Upscale** – Process variable driven beyond full scale

**Fault Detection Level Percentage**

Set a tolerance level, between 0 and 100% of the engineering range, to allow for deviation of the input signal above or below the input span before an input failure is detected.

**Example** – setting the fault detection level to 10% on input range of 50 (**Engineering Range Low**) to 250 (**Engineering Range High**) bar causes an analog input failure fault to be detected below 30 bar and above 270 bar.

**Notes.**

- On some ranges the input circuitry may saturate before the fault level setting is reached. In this case, an error is detected below the level set.
- If an input exceeds the minimum or maximum value for the selected linearizer, an error is detected regardless of the fault level setting.

**Pen Filter**

Filters the process variable input, i.e. if the input is stepped it smooths the transition between steps and may also be used for some degree of cleaning of noisy inputs. The filter time represents the time a step in the input takes to change the displayed process variable from 10 to 90% of the step.

Set the value required, between Off and 60 seconds in 1 second increments.



Return to top of page.

...3.5 Channels Configuration

Pen X Function  
set to **Event**  
(Section 3.13)

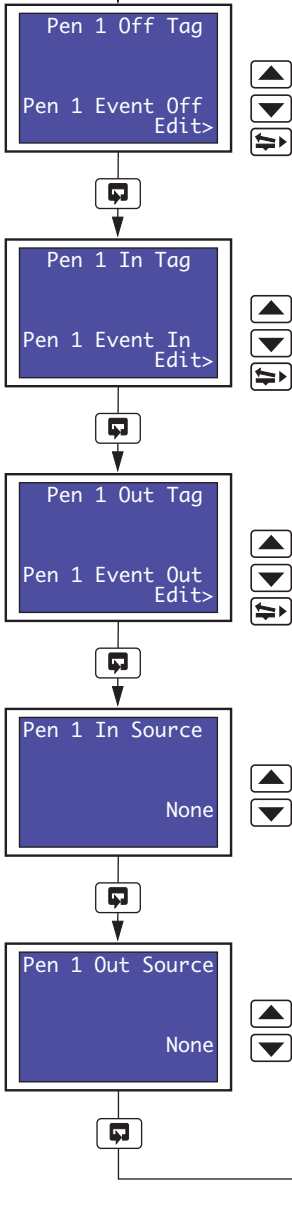

**Pen Off Tag**

Use the key to open the Edit screen.

Use the , and keys to enter the pen off tag required – see Fig. 2.1 on page 6.

Press the key to close the edit screen and save the tag.

**Pen In Tag**

Use the key to open the Edit screen.

Use the , and keys to enter the pen in tag required – see Fig. 2.1 on page 6.

Press the key to close the edit screen and save the tag.

**Pen Out Tag**

Use the key to open the Edit screen.

Use the , and keys to enter the pen out tag required – see Fig. 2.1 on page 6.

Press the key to close the edit screen and save the tag.

**Pen In Source**

Select a digital source to move the pen inwards on the chart.

Refer to Appendix 1 for description of sources.

**Pen Out Source**

Select a digital source to move the pen outwards on the chart.

Refer to Appendix 1 for description of sources.

Return to top of page.

### 3.6 Alarms Configuration

**Overview.**

- **Four alarms per channel** – identified A1 to D1 (for channel 1) up to A4 to D4 (for channel 4).
- **High/Low process alarms.**
- **Fast/Slow rate alarms.**
- **Adjustable hysteresis value** – prevents oscillation of alarm state.
- **Time hysteresis** – enables delayed triggering of alarms.

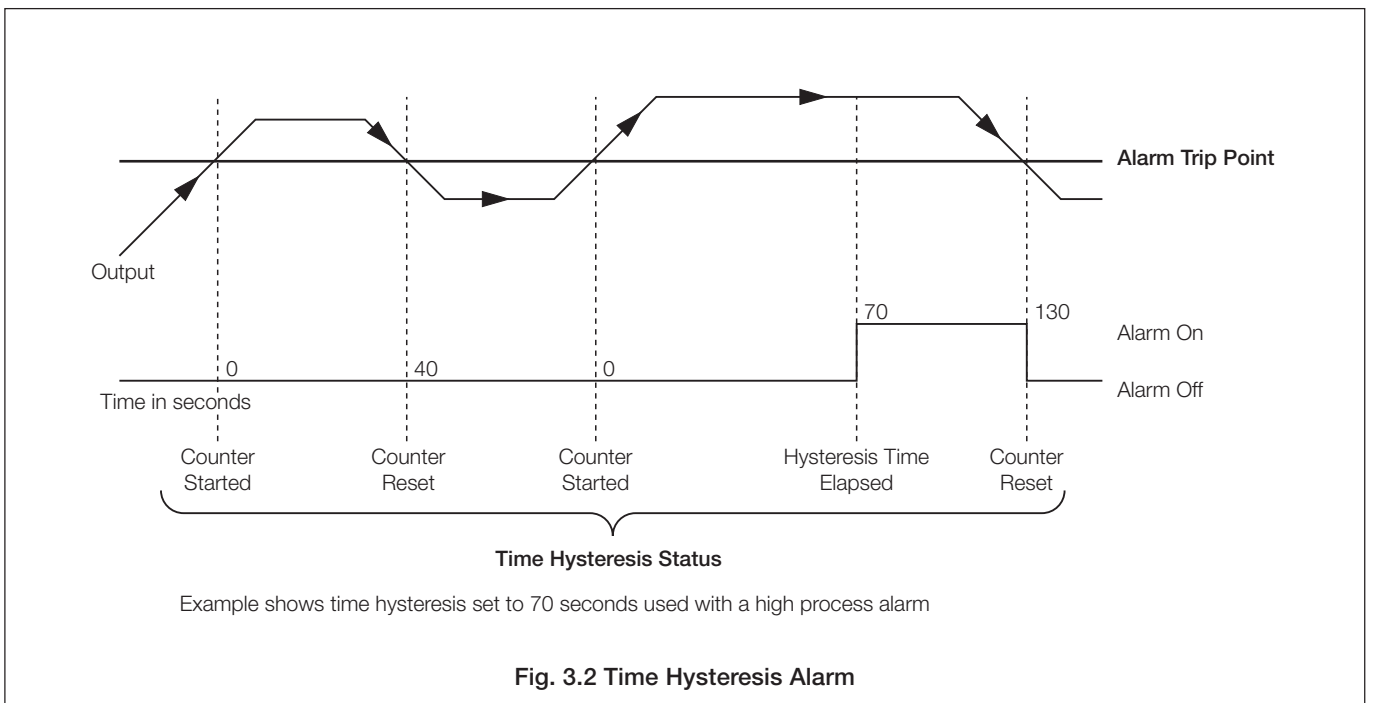
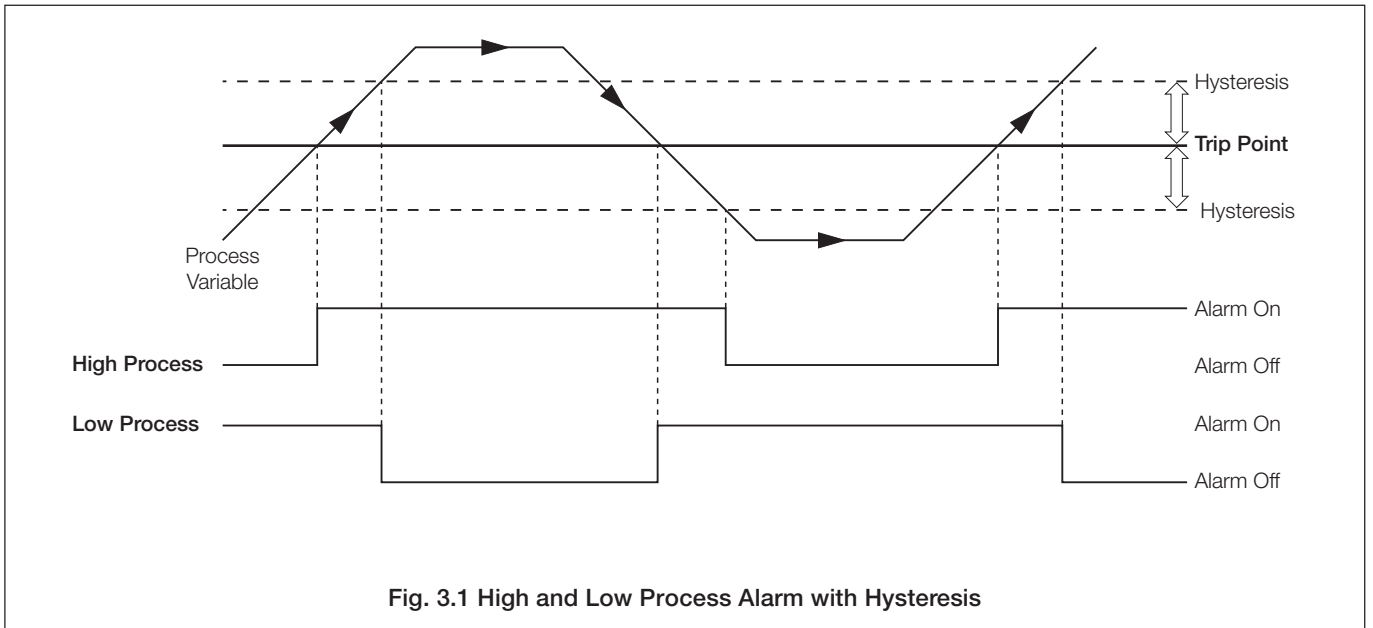



...3.6 Alarms Configuration

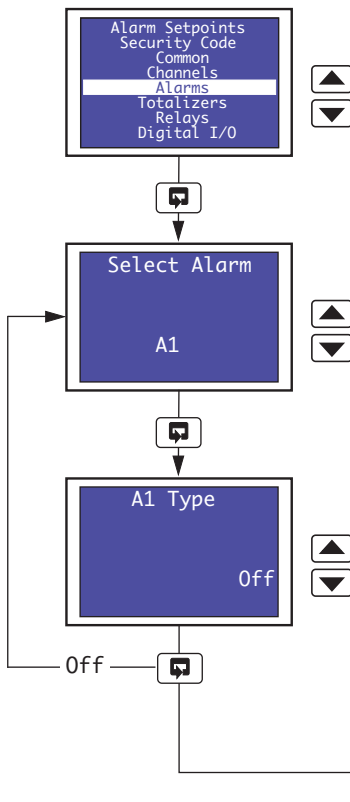

**Alarms Configuration**

Press the  key to open the **Main Menu**.

Highlight **Alarms**.

**Select Alarm**

Select the alarm to be configured.

**Alarm Type**

Select the alarm type required:

- Off** – No alarm
- High Process** – See Fig. 3.1
- Low Process** – See Fig. 3.1
- Fast Rate** – See Fig. 3.3
- Slow Rate** – See Fig. 3.4

Continued on next page.

...3.6 Alarms Configuration

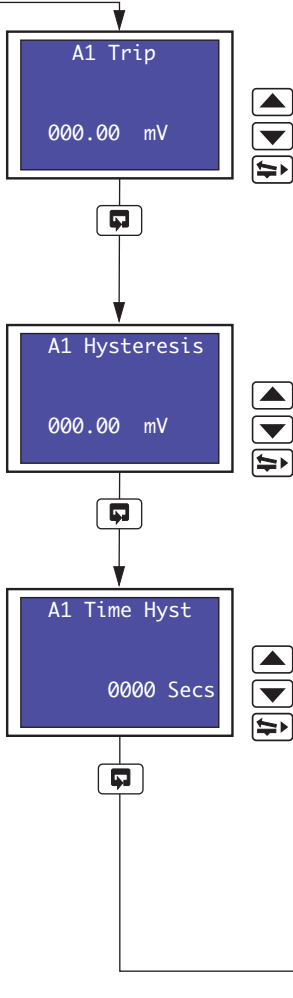

**Trip Level**

Set the value at which the alarm is to activate.

For High and Low Process alarms, the value is set in engineering units.

For Fast and Slow Rate alarms, the trip level is set as a percentage of the engineering span (engineering range high – engineering range low) per hour, between –500 and 500% in 0.1% increments.

**Hysteresis**

Set the hysteresis value, either in engineering units (High and Low Process alarms) or as a percentage of the engineering span (Fast and Slow Rate alarms).

Hysteresis is operational only when the alarm is active. The alarm is activated at the trip level but is de-activated only after the alarm variable has moved into the safe region by an amount equal to the hysteresis value. For rate alarms this setting is a percentage of the trip level.

**Time Hysteresis**

Set the time hysteresis value required, between 0 and 9999 seconds.

If a **Time Hysteresis** value is set, the alarm becomes active only when the alarm condition is present continuously for the time set.

If a **Hysteresis** value is also set (see above) and an alarm is activated, the alarm remains active until the process variable moves outside the hysteresis band. When the alarm condition no longer exists the alarm becomes inactive immediately, i.e. time hysteresis does not affect turning off of alarm states.

### 3.7 Totalizer Configuration

#### Overview.

- **Up to four 9-digit totalizers** – assignable to any pen, analog input or math block (if math software option enabled by installation of the appropriate software key).
- **Count up or count down.**
- **Automatic count rate calculation** – wherever possible, the recorder calculates the count rate automatically according to source units, totalizer units and engineering range, from 0.0001 to 99.9999 counts/second.
- **External counter pulse** – can be used to energize relays or digital outputs (a maximum of 4 pulses per second are generated).
- **Wrap function** – with external wrap pulse used to energize relays or digital outputs.
- **Programmable preset and predetermined count values** – for (batch) flow total.
- **Adjustable cut-off values.**
- **Operator level reset and stop/go.**
- **Digital signal reset and stop/go.**

When enabled by installation of the appropriate software key, the totalizer software provides indication and recording of flow rates from input signals with linear, square law or power law characteristics. Totalization is available for each channel and can be switched on or off as required.

The flow total for any channel can be viewed on the same display screen as the input (pen) channel to which it is assigned. The flow total can also be reset using the control keys on the associated faceplate. An additional internal 'Secure' total is also provided that can be reset only in the Totalizer Configuration level.

External counters with their own power supplies can be driven using 4 relay and digital output module options.

#### Count Rate

Totalizers are normally used in flow applications and their purpose is to summate the volume of process fluid passing the point of measurement. Totalizers have no relationship to time and continue to count up or down (dependant on setting) until instructed to reset. A trip meter on a typical family car is an example of a basic totalizer – the meter counts and displays the distance travelled by the vehicle until reset by the driver. In this example, the speedometer and trip meter read in the same unit of distance.

Flow totalization is more complex than that of a trip meter. In flow totalization, the flow recorder typically measures the instantaneous value in one flow unit whilst the totalizer counts in a larger flow unit. When configuring a totalizer, a count rate must be calculated and entered to compensate for the difference between the totalized measurement unit and the instantaneous measurement unit.

Where possible, the recorder calculates automatically the count rate for the most popular measurement units, e.g. gallons, cubic feet, liters and cubic meters. When configuring a totalizer, first ensure that the unit of measurement (**Channel Units**) selected for the channel to which the totalizer is assigned is a volumetric unit (i.e. quantity per unit of time, for example gallons per hour) – see Section 3.5. Then enter the required Totalizer unit of measurement. If the recorder holds the relationship data between the selected measurement and totalizer units, '**Automatic**' is displayed under the count rate to indicate that it has been set automatically. If the relationship data is not in the recorder's look-up table, '**Manual**' is displayed and the count rate must be set manually – see next page.

---

## ...3 CONFIGURATION

---

### ...3.7 Totalizer Configuration

#### Calculating The Count Rate Manually

The count rate determines how many units the totalizer increments per second when the flow input signal is at 100%. To calculate this parameter manually, follow the procedure below:

##### 1 – Calculate the volume relationship

Typically the unit of measure used by the totalizer is larger than that used for displaying the instantaneous flow-rate. Use standard conversion tables to calculate how many times the flow units used for the input will fit into the desired totalizer unit.

**Example:** Measurement channel units is set to gallons/minute. Instantaneous process flow-rate (engineering range) is 0-300 imperial gallons/minute, totalizer is required to increment in cubic feet. From standard conversion tables, 1 cubic foot = 6.229 imperial gallons.

##### 2 – Calculate the unit time

Ensuring that the time-base of the instantaneous flow-rate is used, the following equation determines how many seconds it will take at full scale flow for a single totalizer unit to pass the measurement point:

$$\frac{\text{Volume relationship}}{\text{Full scale flow}} \times \text{number of seconds in time-base} = \text{Seconds to pass one totalizer unit}$$

**Example:**

$$\frac{6.229 \text{ (imperial gallons in 1ft}^3\text{)}}{300 \text{ (imperial gallons max.flow rate)}} \times 60 \text{ (seconds in 1 minute)} = 1.2458 \text{ seconds to pass 1ft}^3$$

##### 3 – Calculate the count rate

The totalizer count rate is the reciprocal of the result of the calculation above:

$$\frac{1}{\text{Seconds to pass 1 totalizer unit}} = \text{Totalizer count rate}$$

**Example:**

$$\frac{1}{1.2458} = 0.803$$

...3.7 Totalizer Configuration

**Note.** Totalizer configuration is available only if the totalizer software option is enabled by installation of the appropriate software key.

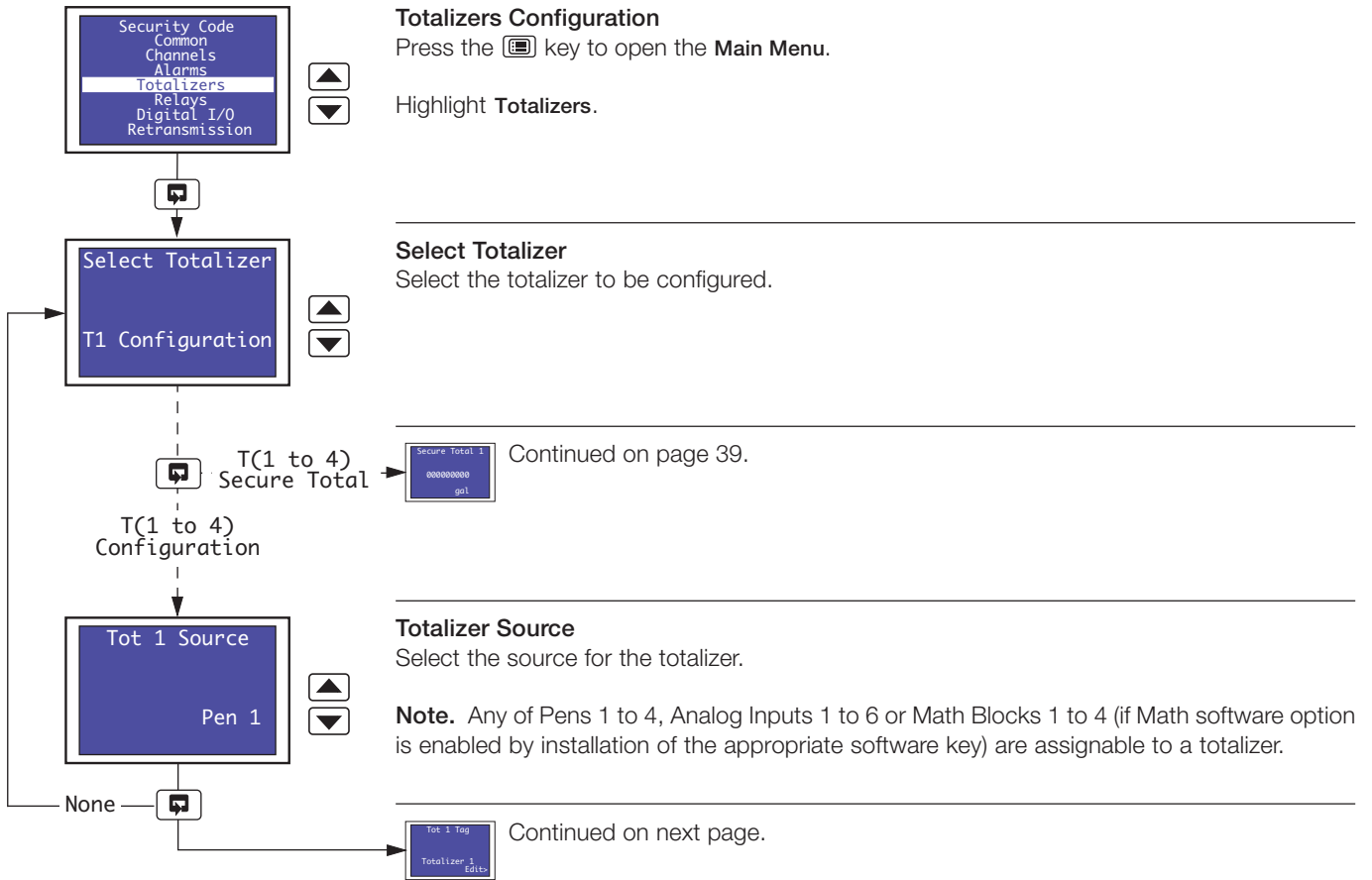

### ...3 CONFIGURATION

#### ...3.7 Totalizer Configuration

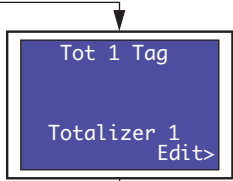

##### Totalizer Tag

Use the key to open the Edit screen.

Use the , , and keys to enter the channel tag required – see Fig. 2.1 on page 6.

Use the key to close the edit screen and save the tag.

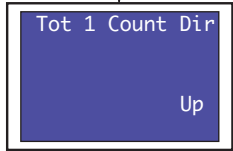

##### Count Direction

Select the count direction:

**Up** – Incremental counter (Preset Value < Predetermined Value)

**Down** – Decremental counter (Preset Value > Predetermined Value)

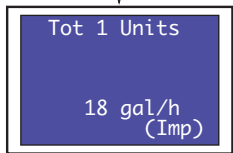

##### Totalizer Units

Select any one of the 112 units pre-programmed into the recorder or select **113 Custom** and use the , , and keys to enter the units required – see Fig. 2.1 on page 6.



Continued on next page.

## ...3.7 Totalizer Configuration

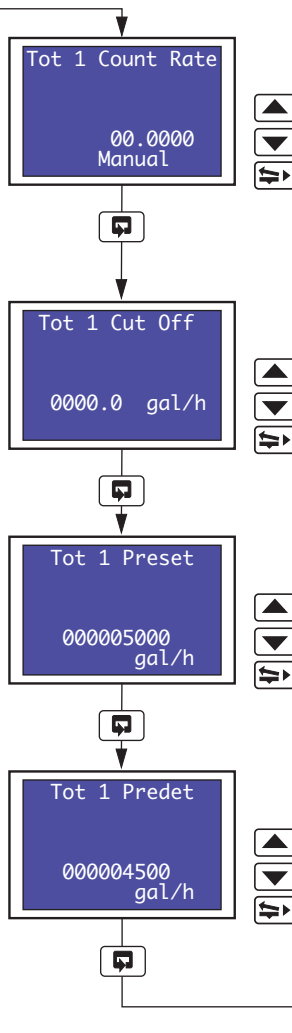
**Totalizer Count Rate**

**Automatic** – the recorder has calculated the count rate automatically. No further adjustment is possible.

**Manual** – the count rate must be calculated manually (see page 34). Use the , and keys to enter the calculated count rate in pulses per second, from 00.0000 to 99.9999 in 0.0001 increments.

**Totalizer Cut Off**

Set the value, in engineering units, at which the totalizer is to stop counting.

**Totalizer Preset Value**

Set the value, in engineering units, from which the totalizer is to start counting and the value that is applied when the totalizer is reset.

**Totalizer Predetermined Value**

Set the value, in engineering units, at which the totalizer stops or wraps.

Continued on next page.

...3.7 Totalizer Configuration

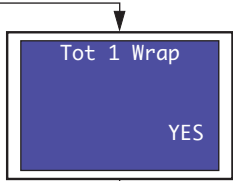

Tot 1 Wrap  
YES



**Totalizer Wrap**

Select the required totalizer wrap action:

- YES – the total is reset automatically to the preset value when the predetermined value is reached.
- NO – the count stops when the predetermined value is reached

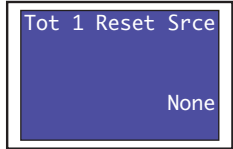

Tot 1 Reset Srce  
None



**Totalizer Reset Source**

If required, select a digital signal to reset the totalizer or select **Timed** to configure the totalizer to reset at a predetermined time.

Refer to Appendix 1 for description of sources.



Timed



Tot 1 Run Source  
None

Anything other than **Timed** selected – continued on next page.

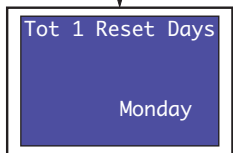

Tot 1 Reset Days  
Monday



**Totalizer Reset Day**

Select the day or days on which the totalizer is to reset:

- Monday to Sunday** – the totalizer resets on the day selected
- Mon-Fri** – the totalizer resets every Monday to Friday inclusive
- All** – the totalizer resets every day
- 1st of Month** – the totalizer resets on the 1<sup>st</sup> day of every month

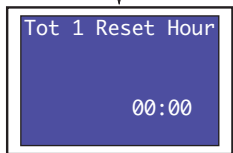

Tot 1 Reset Hour  
00:00



**Totalizer Reset Time**

Select the time of day at which the totalizer is to reset, from 00:00 (midnight) to 23:00 (11 pm) in 1 hour increments.



Tot 1 Run Source  
None

Continued on next page.

...3.7 Totalizer Configuration

Tot 1 Run Source  
None

▲  
▼

**Totalizer Run Source**

If required, select a digital signal to start the totalizer.

Refer to Appendix 1 for description of sources.

Tot 1 Log Enable  
None

▲  
▼

**Totalizer Log Enable Source**

If required, select the frequency at which the addition of the current totalizer values to the totalizer log is triggered:

- None** – current totalizer values are not added to the totalizer log
- Prior to reset** – current totalizer values are added as the totalizer resets
- 12 hours** – current totalizer values are added every 12 hours
- 24 hours** – current totalizer values are added every 24 hours

Select Totalizer  
T1 Configuration

Return to top of page.

Select Totalizer  
set to  
T1 Secure Total

Secure Total 1  
000000000  
gal

**Totalizer Secure Total**

T1 Secure Reset  
NO

▲  
▼

**Secure Total Reset**

Select **YES** to reset the secure total.

The secure total is reset to either 000000000 (**Count Direction** set to **Up**) or 999999999 (**Count Direction** set to **Down**).

Select Totalizer  
T1 Secure Total

Return to top of page.

### 3.8 Relay Configuration

**Overview.**

- **Relays** – can be energized by alarms, logic equation results (math software option enabled by installation of the appropriate software key), digital inputs, real time events (timer software option enabled by installation of the appropriate software key) and totalizer wrap signal (totalizer software option enabled by installation of the appropriate software key)
- **External totalizer count function** – external counter can be driven only by Module Type 3 (4-relay module) fitted in module positions 4, 5 or 6 (see Section 5.2).
- **Polarity** – allows failsafe settings

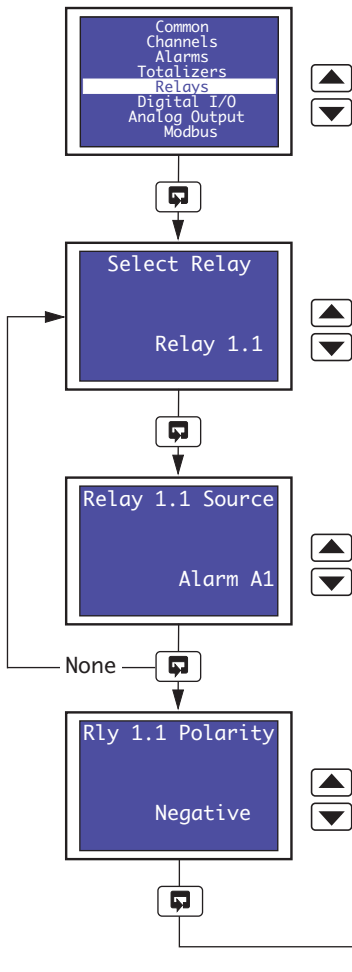
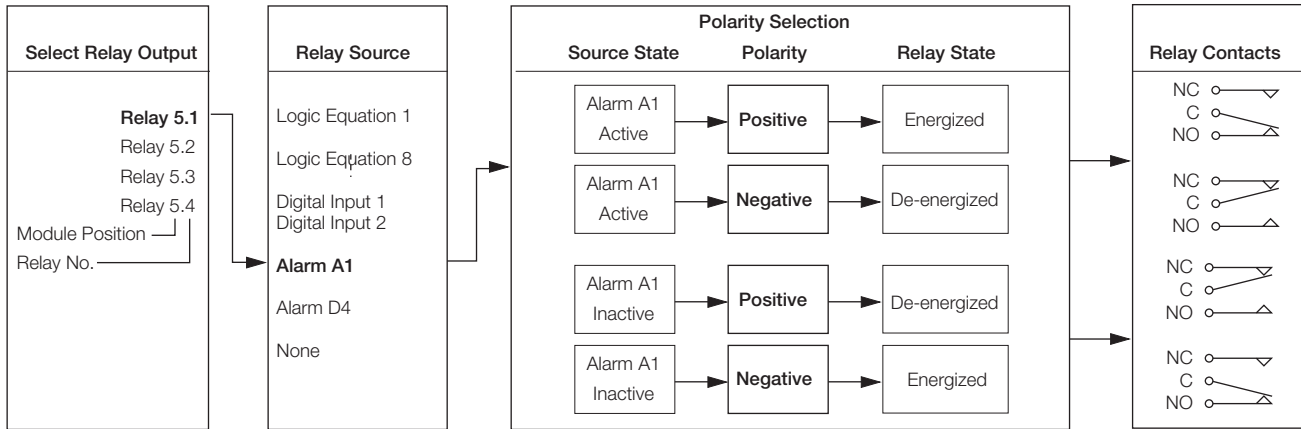

**Relay Configuration**

Press the key to open the Main Menu.

Highlight Relays.

**Select Relay**

Select the relay to be configured.

**Relay Source**

Select the source required to activate the selected relay.

Refer to Appendix 1 for description of sources.

**Relay Polarity**

Select the polarity required for the selected relay:

**Positive** – relay is energized when the relay source is active (On)

**Negative** – relay is energized when the relay source is inactive (Off)

Return to top of page.

### 3.9 Digital Input and Output Configuration

**Overview.**

- The **Digital I/O** menu selection is displayed only if a digital input/output module is fitted – see Section 5.3.3.
- **Up to 24 digital outputs available** – depending on the module types fitted.
- **Digital outputs** – can be energized by alarms, logic equation results (math software option enabled by installation of the appropriate software key), digital inputs, real time events (timer software option enabled by installation of the appropriate software key) and totalizer wrap signal (totalizer software option enabled by installation of the appropriate software key).
- **External Totalizer count function** – external counter can be driven only by Module Type 5 (8-digital output module) fitted in module positions 4, 5 or 6 (see Section 5.2).
- **Polarity** – inverts the effect of the selected source on the output state.

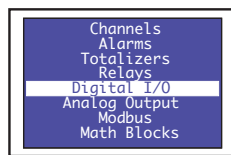
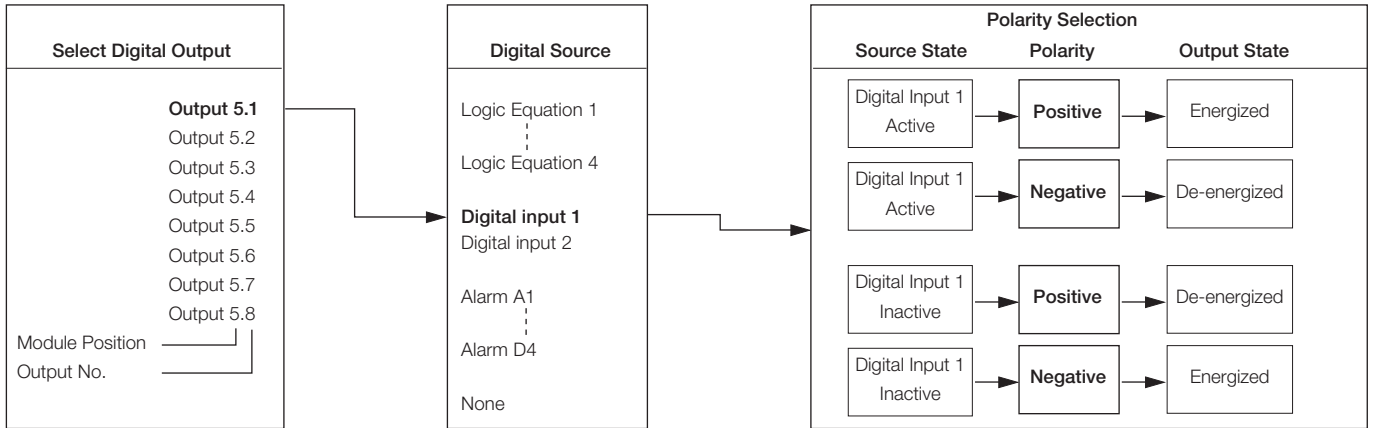

**Digital I/O Configuration**

Press the key to open the **Main Menu**.

Highlight **Digital I/O**.

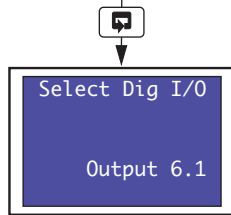

**Select Digital Input/Output**

Select the digital input or output to be configured.



**Output X.X selected** – continued on next page.



**Input X.X selected** – continued on next page.

...3.9 Digital Input and Output Configuration

Select Dig I/O  
set to  
Output X.X

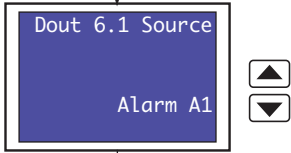

**Digital Output Source**

Select the channel source for the digital output.

Refer to Appendix 1 for description of sources.

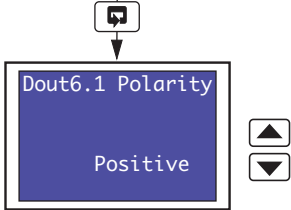

**Digital Output Polarity**

Select the polarity required for the selected digital output:

- Positive** – digital output is energized when the relay source is active (On)
- Negative** – digital output is energized when the relay source is inactive (Off)



Return to top of page.

Select Dig I/O  
set to  
Input X.X

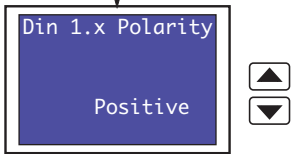

**Digital Input Polarity**

Select the polarity required for the selected digital input:

- Positive** – digital output state is unchanged
- Negative** – digital output state is inverted



Return to top of page.

### 3.10 Analog Output Configuration

**Overview.**

- **Fitted analog outputs** – assignable to retransmit any process variable
- **Selectable analog output range** – allows maximum resolution on range of interest
- **Adjustable output range** – for non-standard and reversed outputs

The example below shows analog output 1 programmed to retransmit part of process variable 1's engineering range (250 to 750°C) as a 4.0 to 20.0 mA current output.

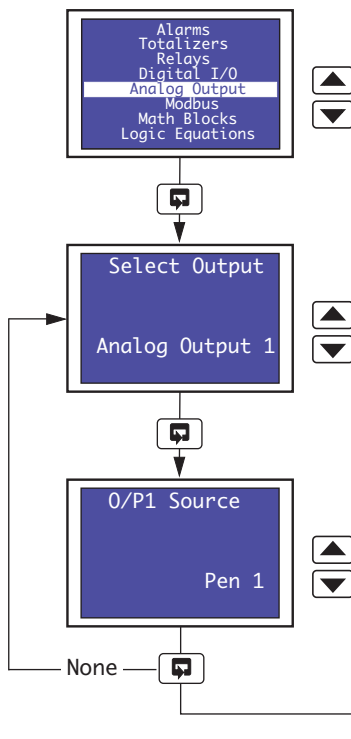
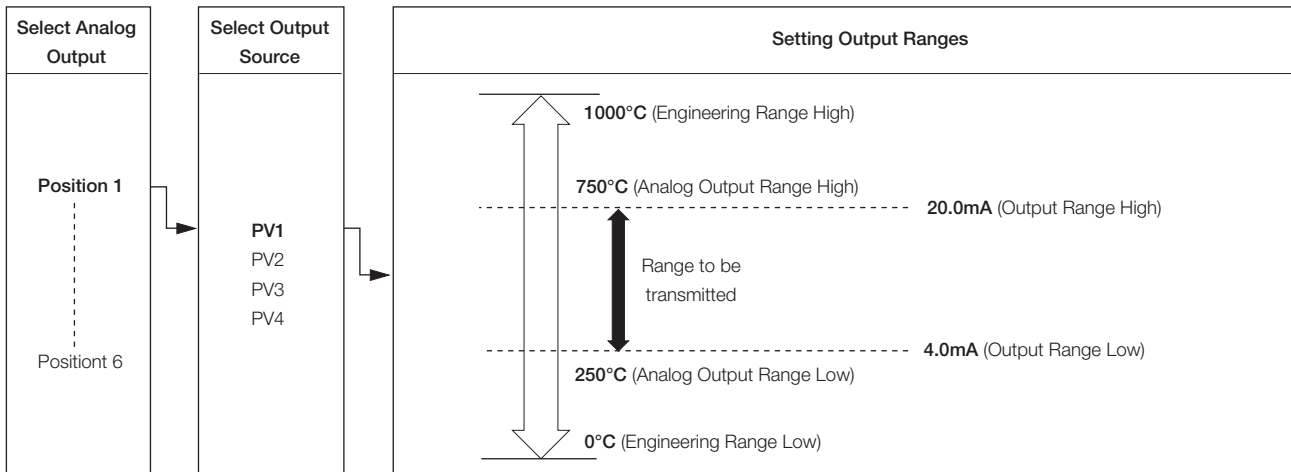

**Analog Output Configuration**

Press the key to open the **Main Menu**.

Highlight **Analog Output**.

**Select Analog Output**

Select the analog output to be configured.

**Analog Output Source**

Select the source for the analog output.

Refer to Appendix 1 for description of sources.

Continued on next page.

## ...3 CONFIGURATION

### ...3.10 Analog Output Configuration

O/P1 Range High  
010.00 mV

#### Analog Output Range High

Set the engineering range value, in engineering units, at which maximum output is required.

O/P1 Range Low  
000.00 mV

#### Analog Output Range Low

Set the engineering range value, in engineering units, at which minimum output is required.

O/P1 Elect High  
020.0 mA

#### Analog Electrical Range High

Set the maximum current output value to correspond with the **Analog Output Range High**, between 0.0 and 20.0 mA in 0.1 mA increments.

O/P1 Elect Low  
004.0 mA

#### Analog Electrical Range Low

Set the minimum current output value to correspond with the **Analog Output Range Low**, between 0.0 and 20.0 mA in 0.1 mA increments.

Select Output  
Analog Output 1

Return to top of page.

### 3.11 Logic Equation Configuration

#### Overview.

- 8 logic equations
- Up to 4 operands and 3 operators per equation
- OR/AND/XOR/NAND/NOR/NOT operators
- Can combine internal and external digital signals – i.e. alarms, digital inputs, other logic equation results and real-time events (if timer software option enabled by installation of the appropriate software key)

For each equation, the logic elements 1 to 7 are arranged sequentially, as shown below. Odd numbered elements are used for logic inputs (operands) and even numbered elements for logic gates (operators).

Logic inputs must be set to one of the digital sources in Appendix 1.

Logic inputs may be inverted (set to NOT)

Logic gates must be set to AND, OR, XOR, NAND, NOR or END. Setting an element to END terminates the equation.

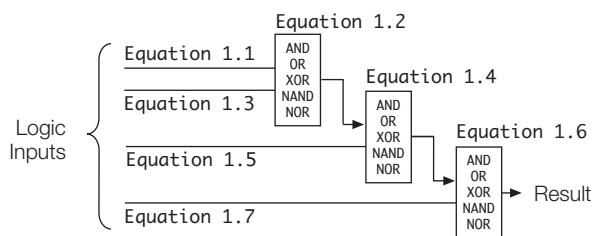

**Note.** The elements of each equation are calculated sequentially, i.e. elements 1, 2 and 3 are evaluated first and the result combined with elements 4 and 5. This result is then combined with elements 6 and 7 to give the logic equation result.

### ...3 CONFIGURATION

#### ...3.11 Logic Equation Configuration

**Example** – Reservoir level monitoring using:

- process variable 1 with an engineering range of 0 to 100 feet
- logic equation 1 result assigned to relay 1.1 that is used to operate the control valve.

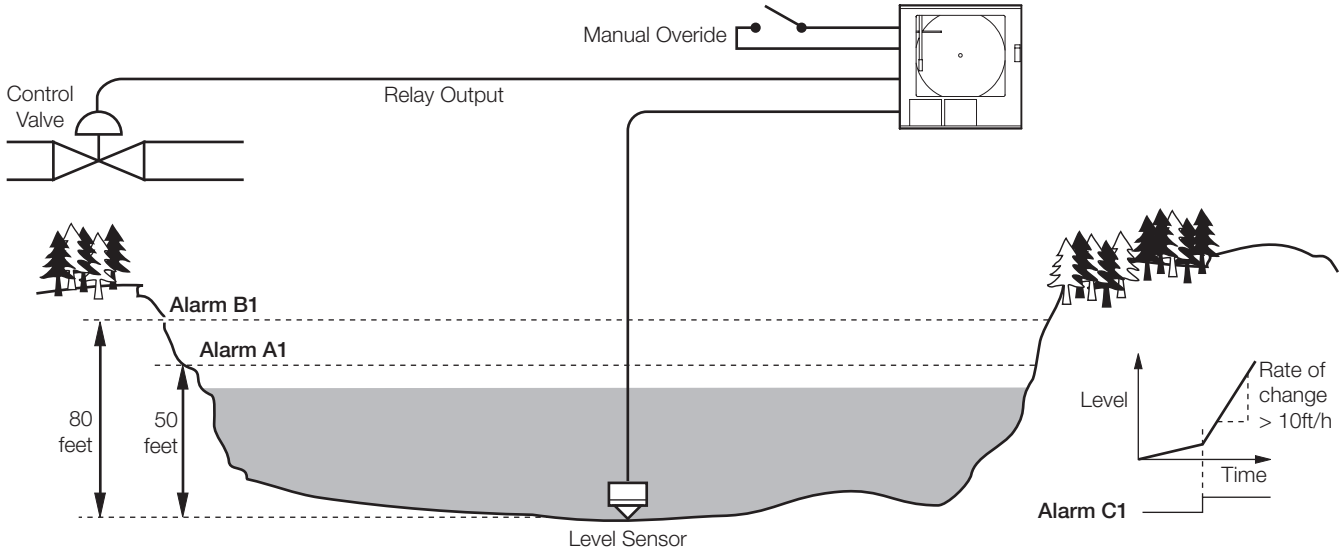

Flow Conditions
Close reservoir control valve if:
<ul style="list-style-type: none"> <li>• Reservoir level &gt;50 feet AND rate of change &gt;10 ft/hr</li> </ul>
<b>OR</b>
<ul style="list-style-type: none"> <li>• Reservoir level &gt;80 ft</li> </ul>
<b>OR</b>
<ul style="list-style-type: none"> <li>• Manual override switch operated</li> </ul>

Input Elements
<ul style="list-style-type: none"> <li>• <b>Alarm A1</b> – set to high process trip at 50 ft</li> <li>• <b>Alarm B1</b> – set to high process trip at 80 ft</li> <li>• <b>Alarm C1</b> – set to fast rate trip at 10% of range per hour (10 ft/hr)</li> <li>• <b>Manual override switch:</b> Connected to digital input 1.1 Digital input number <input type="text"/> Module number <input type="text"/> Negative polarity Volt-free switching</li> </ul>

Entering the Logic Equation
Equation 1.1 ⇔ Alarm A1
Equation 1.2 ⇔ AND
Equation 1.3 ⇔ Alarm C1
Equation 1.4 ⇔ OR
Equation 1.5 ⇔ Alarm B1
Equation 1.6 ⇔ OR
Equation 1.7 ⇔ Digin Main 1

...3.11 Logic Equation Configuration

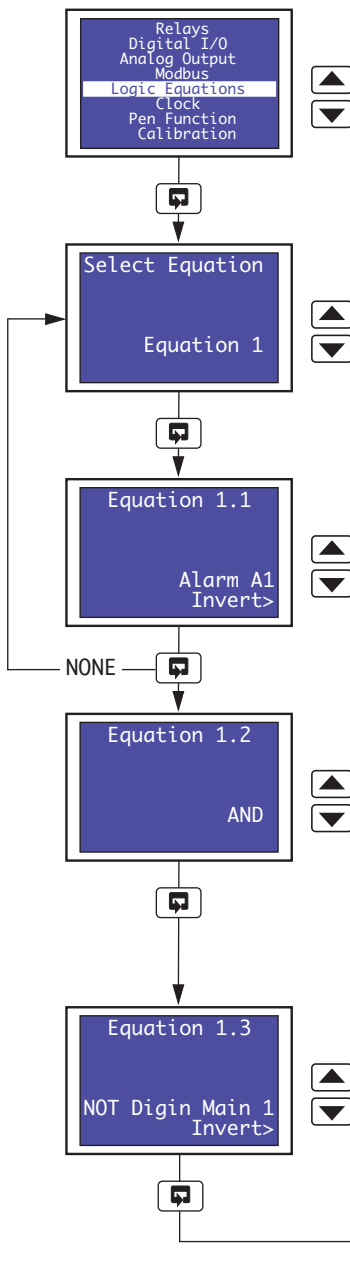

**Logic Equation Configuration**

Press the key to open the **Main Menu**.

Highlight **Analog Output**.

**Select Equation**

Select the equation to be configured.

**Equation n/Element 1**

Select the source required for element 1.

Refer to Appendix 1 for description of sources.

Press the key to logically invert the selected source (set to NOT)

**Equation n/Element 2**

Select the operator required to combine elements 1 and 3:

- END** - Ends equation
- AND** - Output is 1 if both inputs are 1, but 0 for all other possible inputs
- OR** - Output is 1 if one or the other or both inputs are 1, but 0 if both inputs are 0
- XOR** - Output is 1 if either, but not both, inputs are 1, but 0 if both inputs are 0 or 1
- NAND** - Output is 0 if both inputs are 1, but 1 if one or the other or both inputs are 0
- NOR** - Output is 1 if both inputs are 0, but 0 if one or the other or both inputs are 1

**Equation n/Element 3**

Repeat previous two steps for elements 3 to 7.

Odd numbered elements = operands  
Even numbered elements = operators

Return to top of page.

### 3.12 System Clock Configuration

**Note.** The System Clock is available only if any of the Totalizer, Math or Timers software options are enabled by installation of the appropriate software key.

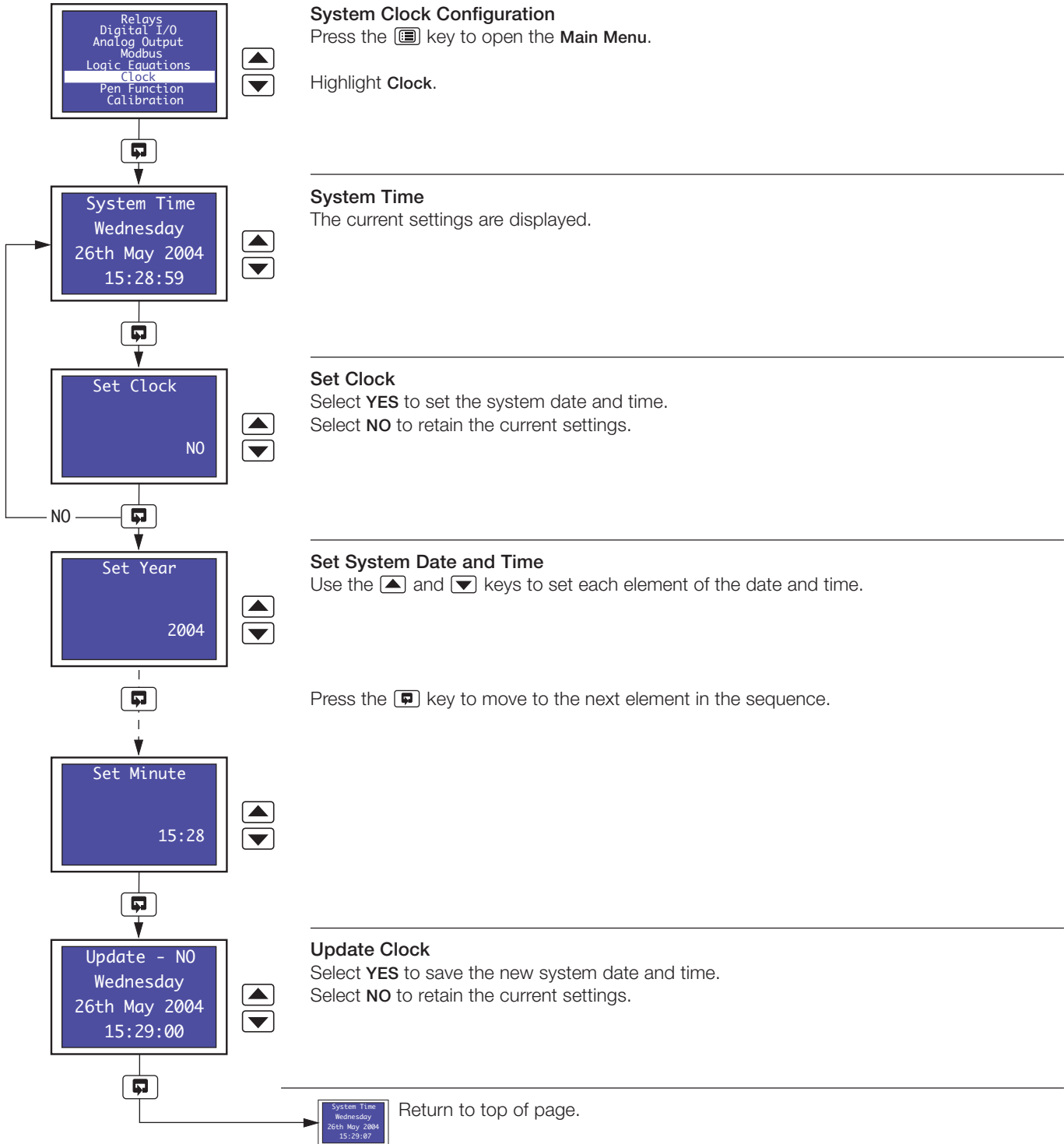

### 3.13 Pen Function

**Overview.**

- **Trend Pens** – the chart range is configured independently of the engineering range (see Section 3.5) to enable a selected part of the engineering range to be used for display thus giving extra detail on the chart.
- **Event Pens** – assigned to digital inputs, alarms, logic equation results and real-time events (if timer software option enabled by installation of the appropriate software key).

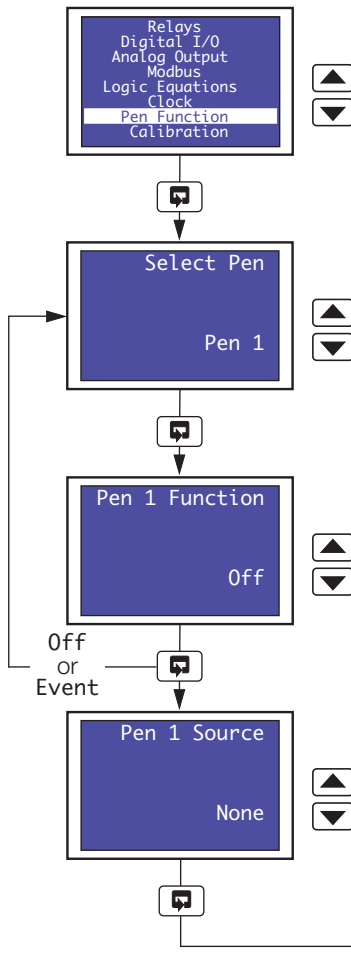
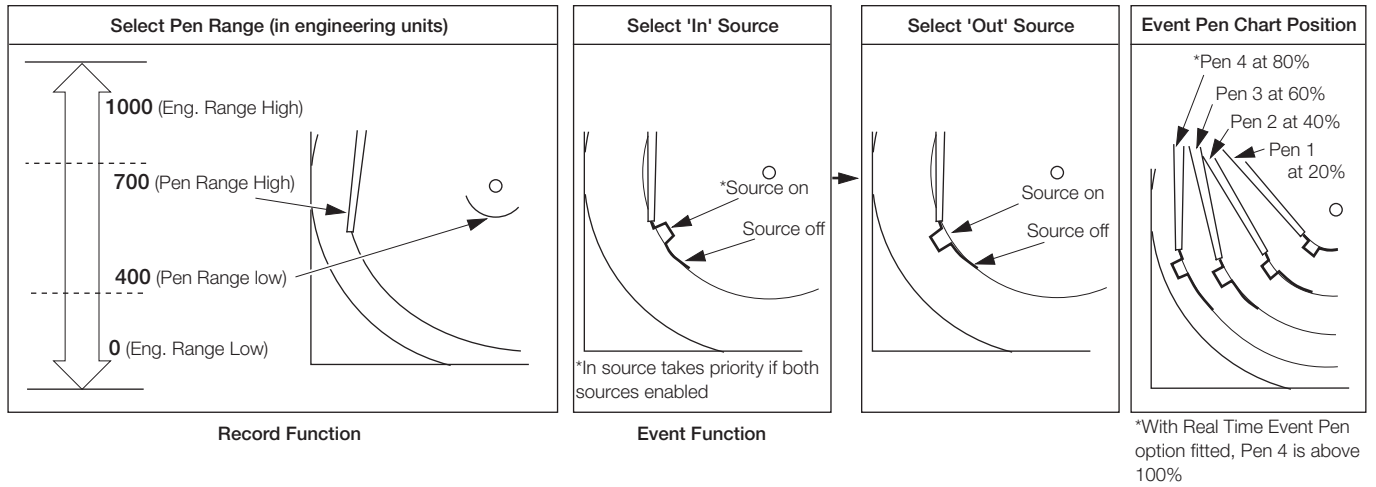

**Pen Function**

Press the key to open the **Main Menu**.

Highlight **Pen Function**.

**Select Pen**

Select the pen to configure.

**Pen Function**

Select the required pen function:

- Off** – No function
- Trend** – Trend
- Event** – Event

**Pen Source**

Select an input source or math block for the selected pen as required.

Return to top of page.

3.14 Calibration

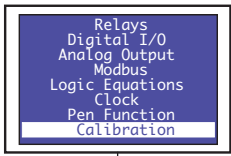

**Pen Configuration**

Press the  key to open the **Main Menu**.

Highlight **Calibration**.

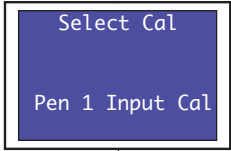

**Select Cal**

Select the pen input channel or pen chart position to calibrate.



Pen X  
Chart Cal

Pen X  
Input Cal



Continued on next page.

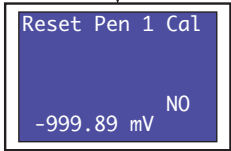

**Reset Pen Calibration**

Select **YES** to reset the offset and span values to their nominal values.  
Select **NO** to retain the current offset and span values.

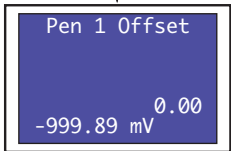

**Offset**

Set the required offset value for the selected pen or analog input.

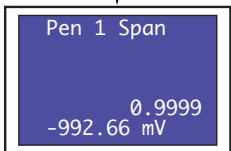

**Span**

Set the required span value for the selected pen or analog input.



Return to top of page.

...3.14 Calibration

Select Cal  
set to  
Pen X Chart Cal

A rectangular screen with a dark blue background. The text "Set Pen 1 High" is at the top, and the number "0" is at the bottom. To the right of the screen are two small square buttons with upward and downward arrows.

**Pen High Value**

Set the required chart high value for the selected pen, between 0 and 200.



A rectangular screen with a dark blue background. The text "Set Pen 1 Low" is at the top, and the number "0" is at the bottom. To the right of the screen are two small square buttons with upward and downward arrows.

**Pen Low Value**

Set the required chart low value for the selected pen, between 0 and 200.



A small rectangular screen with a dark blue background. The text "Select Cal" is at the top and "Pen 1 Chart Cal" is at the bottom.

Return to top of page.

### 3.15 Backing Up and Restoring Configurations

A backup file of the recorder's configuration settings can be saved to a PC and restored to the recorder using the **C1300 Configuration Backup Utility Software** (download from [www.abb.com/recorders](http://www.abb.com/recorders)) and **Configurator Cable, C100/0051** (available from the Company).

#### 3.15.1 Backing Up a Configuration

1. Connect the Configurator Cable to the recorder's configuration backup port (see Fig. 3.5) and the PC's serial port.

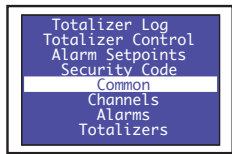
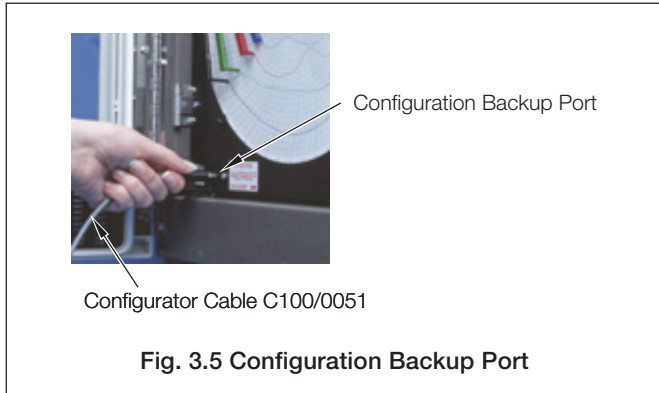

2. Press the  key to open the **Main Menu**.
3. Highlight **Common** (or any of the Configuration level selections below Common).

4. Run the software 'C1300 Configuration Backup Utility.exe' on the PC.
5. Save the current configuration – see Fig. 3.6.

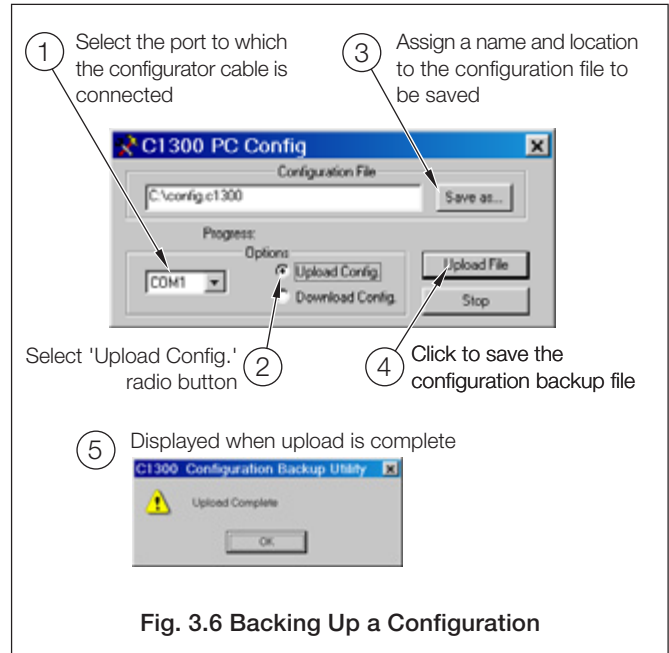

6. Exit the C1300 Configuration Backup Utility Software, remove the Configurator Cable and return the recorder to normal operation – see Section 2.3.1.

### 3.15.2 Restoring a Configuration

1. Connect the Configurator Cable to the recorder's configuration backup port (see Fig. 3.5) and the PC's serial port.



2. Press the  key to open the **Main Menu**.
3. Highlight **Common** (or any of the Configuration level selections below Common).

4. Run the software 'C1300 Configuration Backup Utility.exe' on the PC.
5. Restore the current configuration – see Fig. 3.7.

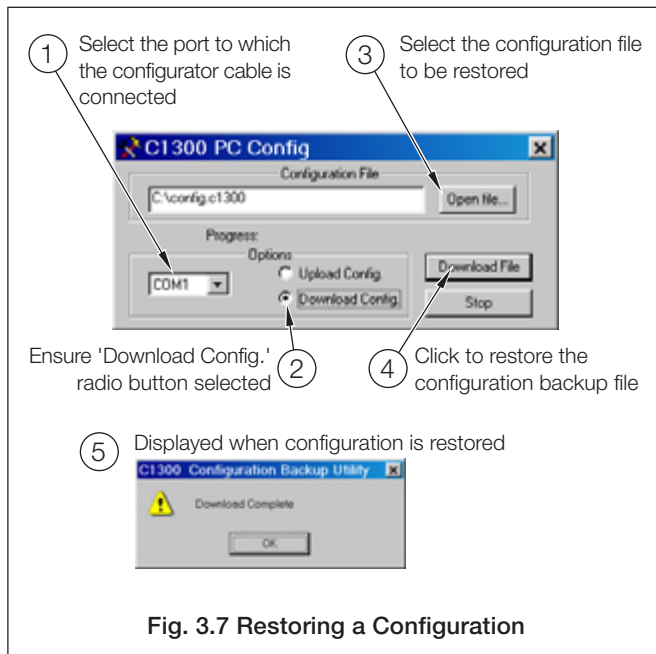

6. Exit the C1300 Configuration Backup Utility Software, remove the Configurator Cable and return the recorder to normal operation – see Section 2.3.1.

## 4 MECHANICAL INSTALLATION

### 4.1 Siting – Figs 4.1 and 4.2

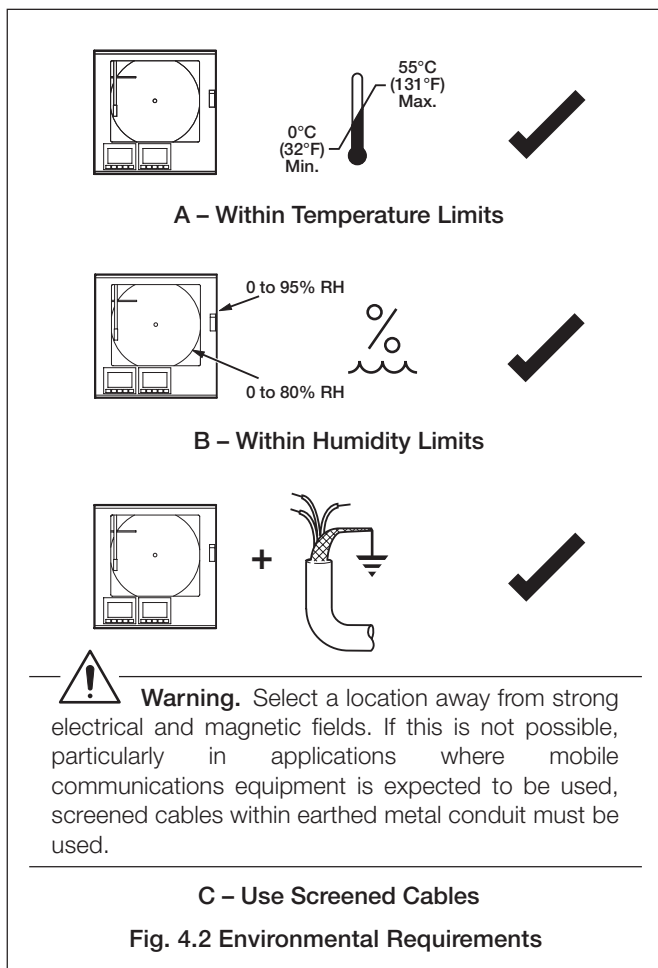
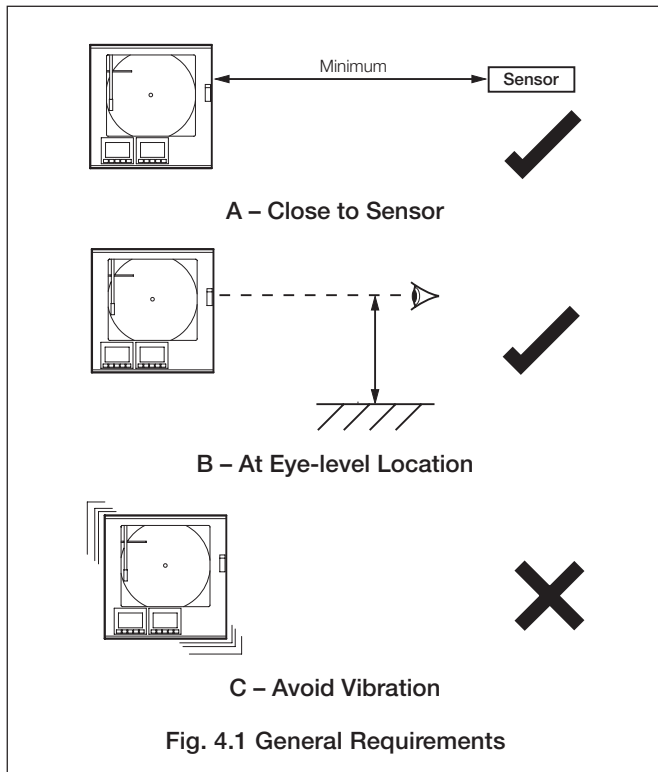

### 4.2 Mounting – Figs. 4.3 to 4.5

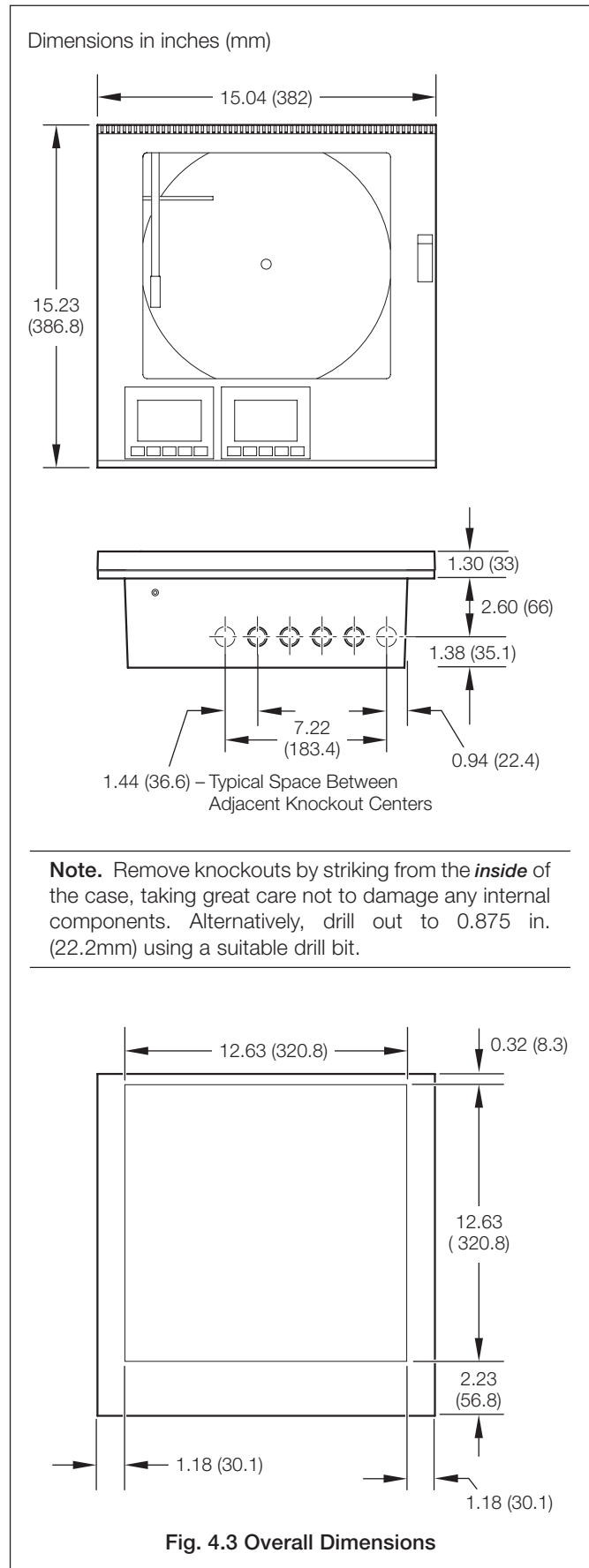

4.2.1 Wall-/Pipe-Mounting – Fig. 4.4

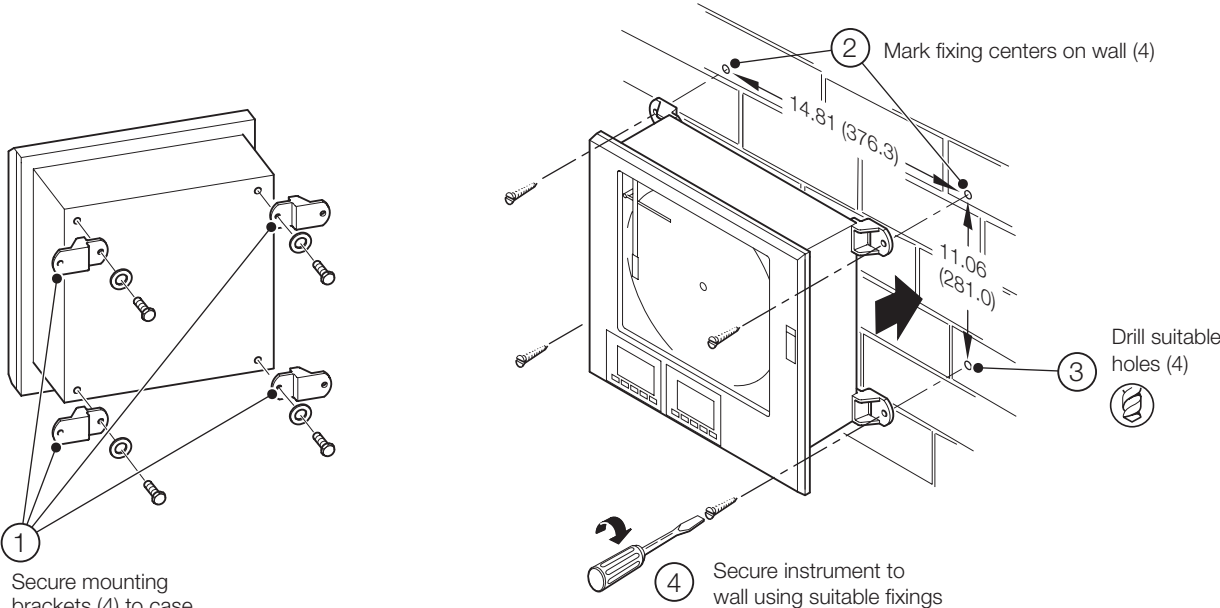

A – Wall-mounting

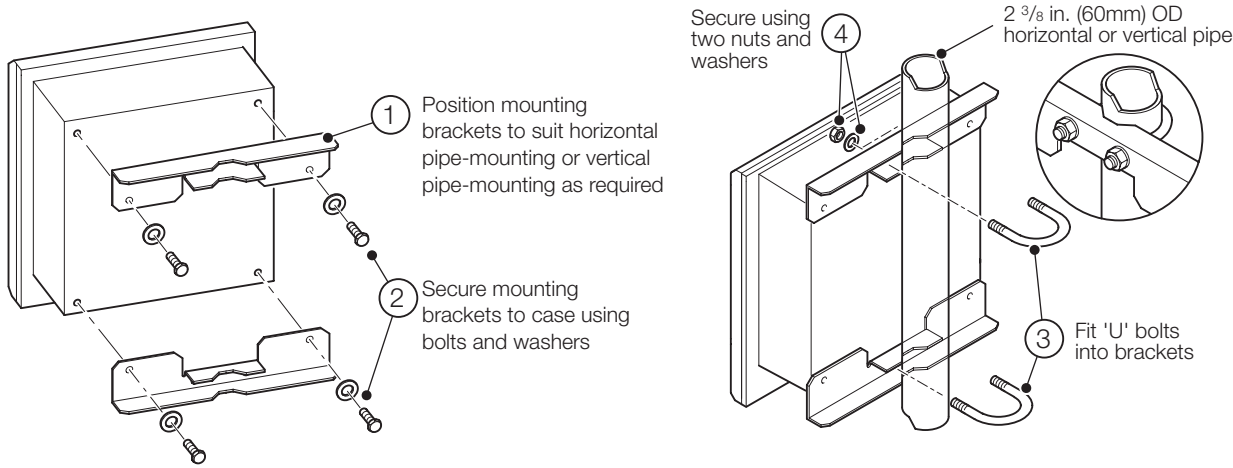

B – Pipe-Mounting (Optional)

Fig. 4.4 Wall-/Pipe Mounting

4.2.2 Panel Mounting – Fig. 4.5

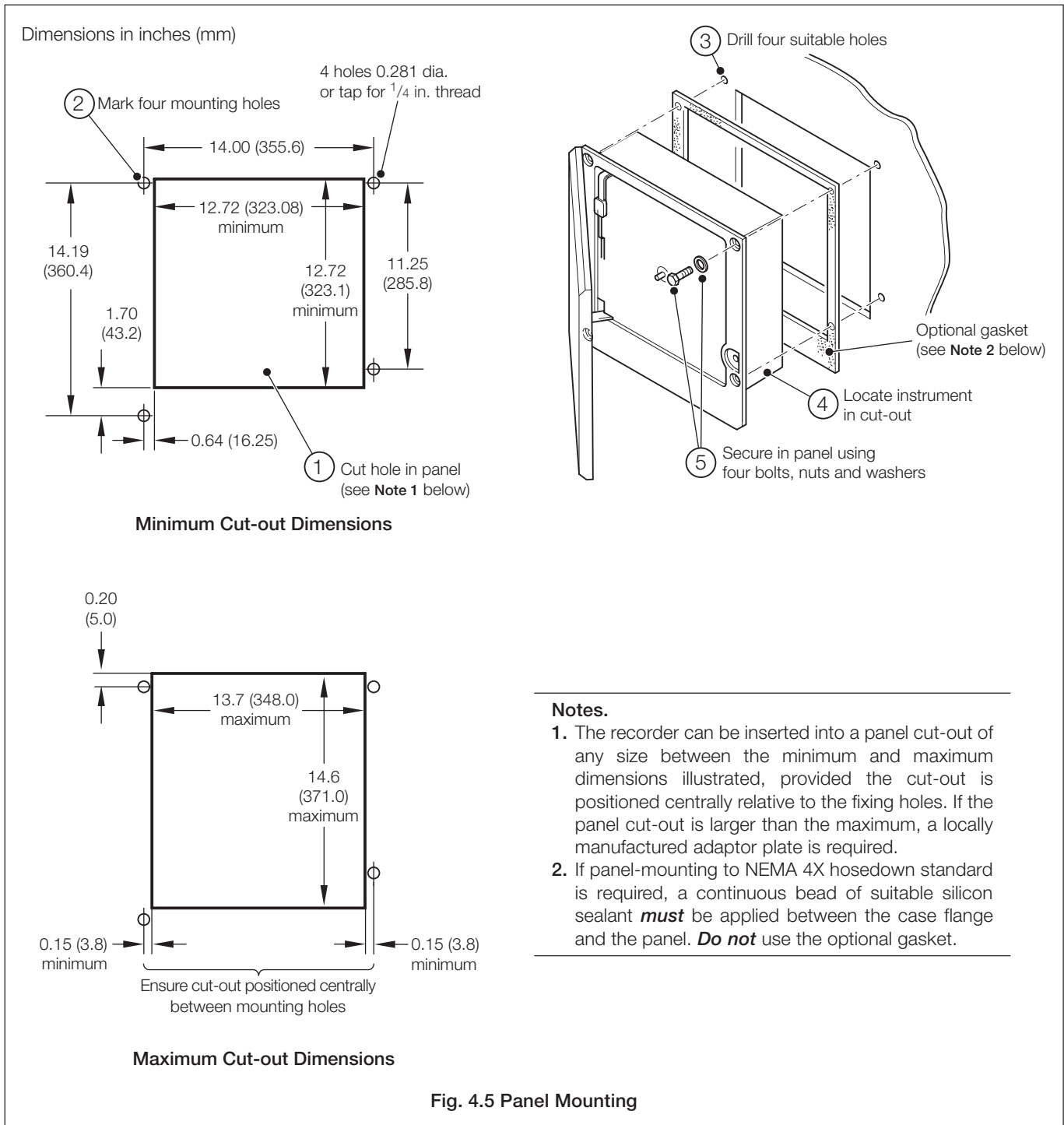

## 5 ELECTRICAL INSTALLATION



### Warnings.

- Recorders not fitted with the optional internal on/off switch and fuse must have an external fuse and disconnecting device such as a switch or circuit breaker conforming to local safety standards fitted to the final installation. They must be fitted in close proximity to the recorder within easy reach of the operator and must be marked clearly as the disconnection device for the recorder.
- Remove all power from supply, relay and any powered control circuits and high common mode voltages before accessing or making any connections.
- Use cable appropriate for the load currents. The terminals accept cables up to 14AWG (2.5mm<sup>2</sup>).
- The power supply and all inputs and outputs conform to Insulation Category II, Pollution Degree II.
- All connections to secondary circuits must have basic insulation.
- After installation, there must be no access to live parts e.g. terminals.
- Terminals for external circuits are for use only with equipment with no accessible live parts.
- If the recorder is used in a manner not specified by the Company, the protection provided by the equipment may be impaired.
- All equipment connected to the recorder's terminals must comply with local safety standards (IEC 60950, EN601010-1).

### Notes.

- Always route signal leads and power cables separately.
- To comply with Underwriter Laboratories (UL) certification, route signal leads and power cables in earthed (grounded), flexible metal conduit.
- Use screened cable for signal inputs and relay connections. Connect the screen to the earth (ground) stud – see Fig. 5.9.
- The terminal blocks can be removed from the main PCB when making connections – see Fig. 5.1. Before removing a module, note its position.
- If wall- or pipe-mounting to NEMA 4X hosedown standard is required, suitable cable glands *must* be used to prevent water ingress.
- The optional Software Key (if fitted), part number C1900/0463, contains a non-replaceable 3.0V lithium cell.

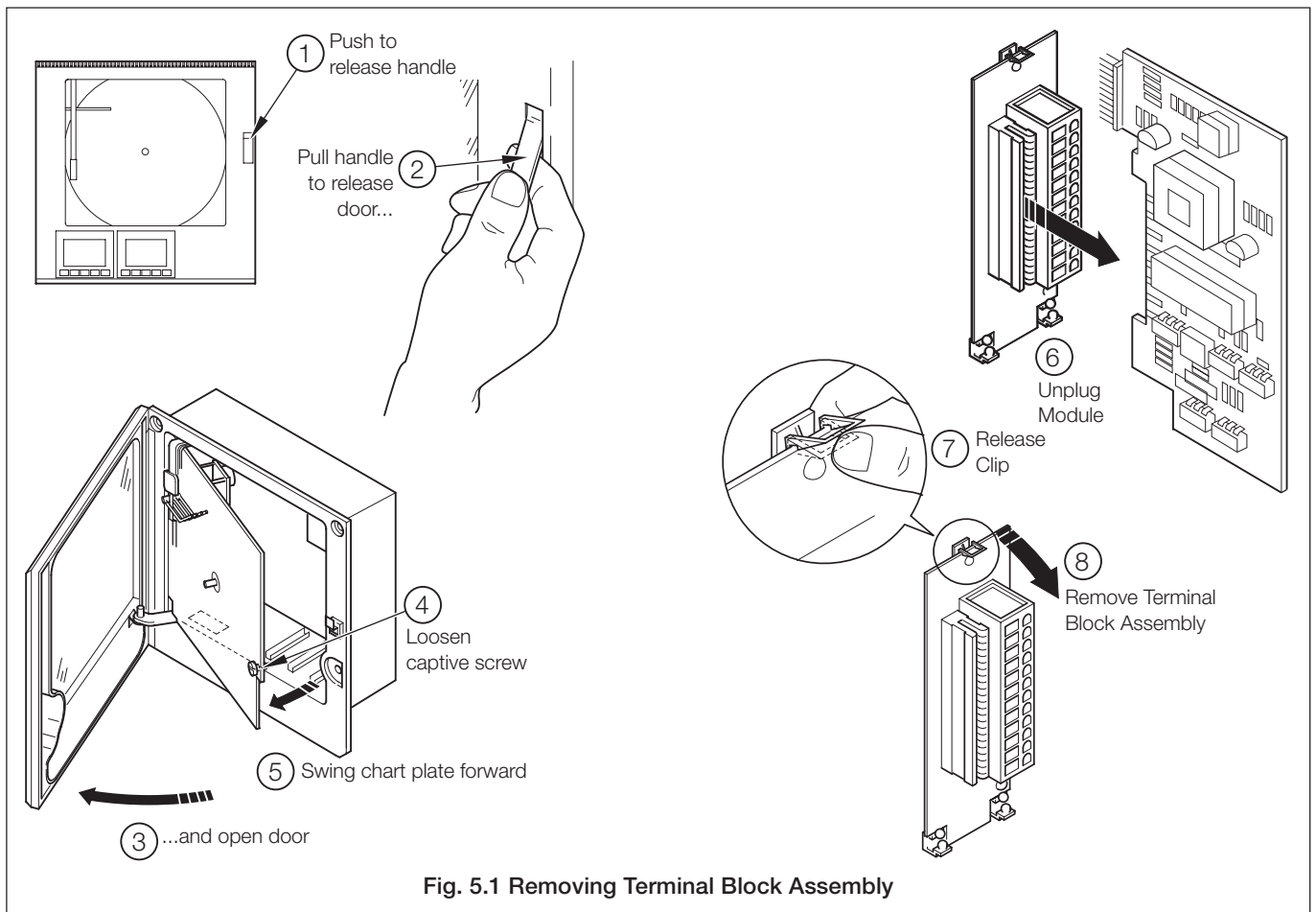

Fig. 5.1 Removing Terminal Block Assembly

### 5.1 Identifying the Input/Output Modules – Fig. 5.1

To gain access to the modules, open the door and chassis – see Fig. 5.1. There are five module positions (2 to 6) as shown in Fig. 5.2.

### 5.2 Channel Connections

**Channel 1 connections** are made directly to the terminal block mounted on the motherboard.

**Other Channel connections** are made to standard I/O modules, fitted in positions 2, 3 or 4 – see Fig. 5.2.



**Warning.** The maximum channel to channel voltage (between any 2 channels) must not exceed 500V DC.

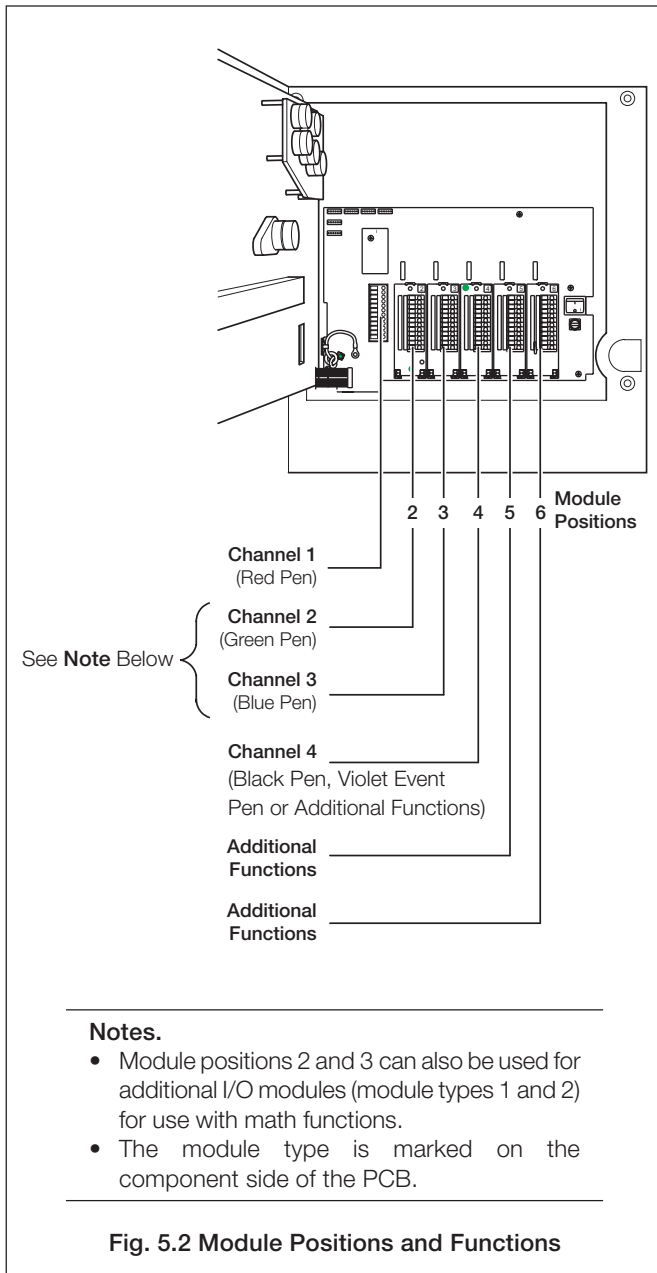
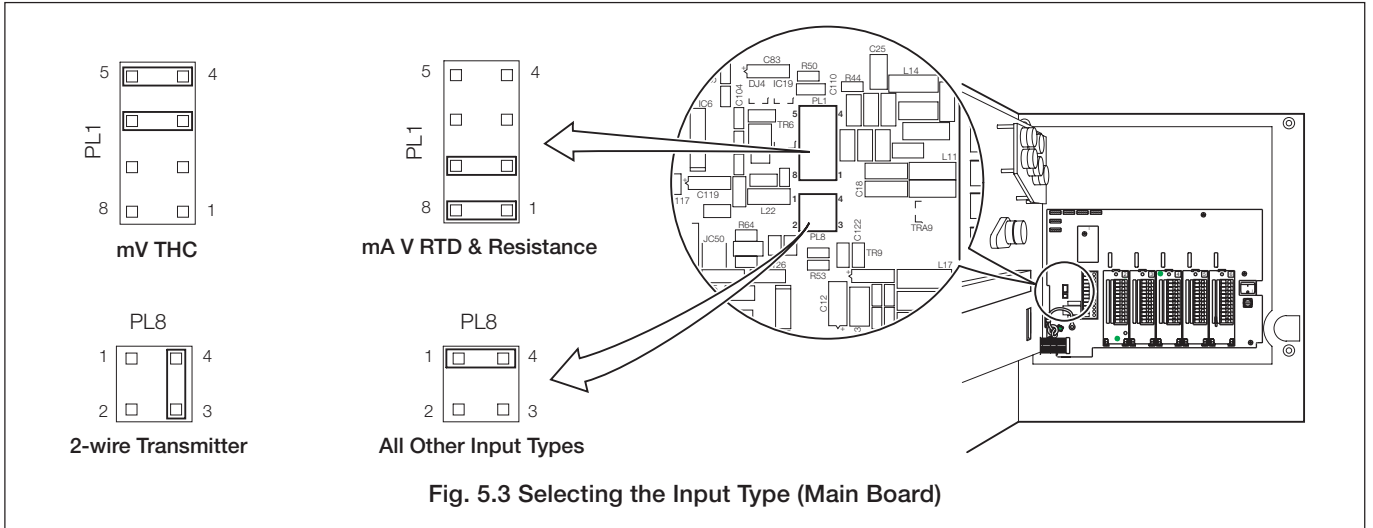

Fig. 5.2 Module Positions and Functions

**5.2.1 Selecting the Analog Input Type(s) – Figs. 5.3 and 5.4**

Plug-in links are used to select the input type:

- Channel 1** PL1 & PL8 on the main p.c.b. (Fig. 5.3)
- Channels 2 to 4** PL1 & PL3 on the module (Fig. 5.4)



**Fig. 5.3 Selecting the Input Type (Main Board)**

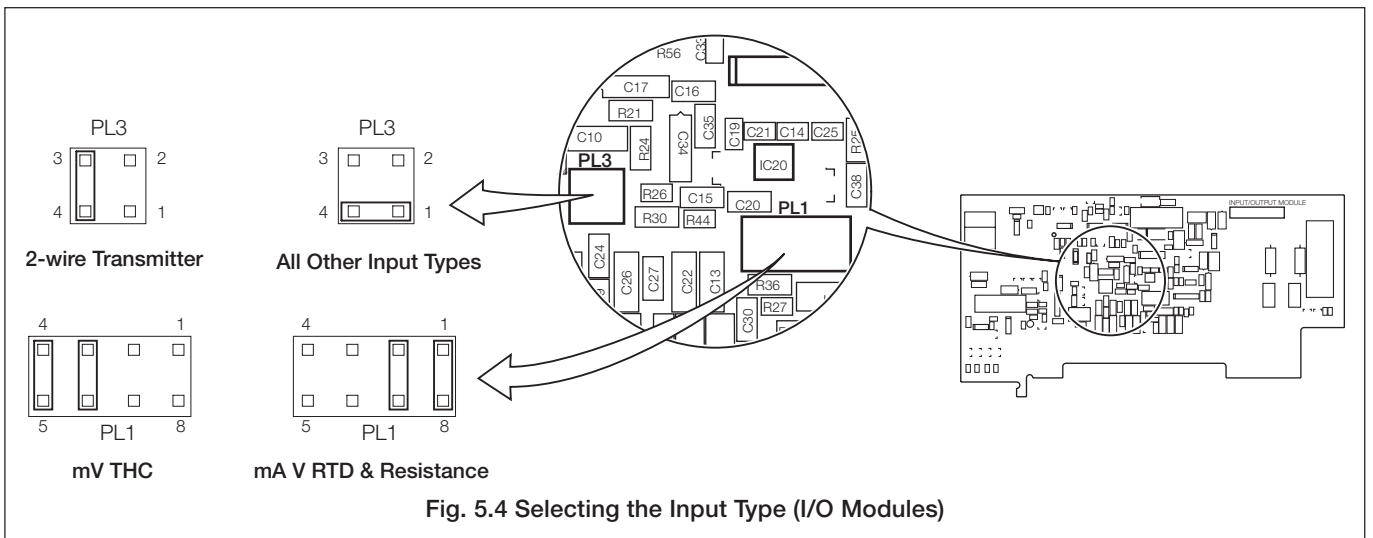

**Fig. 5.4 Selecting the Input Type (I/O Modules)**

Type of Thermocouple	Compensating Cable											
	BS1843			ANSI MC 96.1			DIN 43714			BS4937 Part No.30		
	+	-	Case	+	-	Case	+	-	Case	+	-	Case
Ni-Cr/Ni-Al (K)	Brown	Blue	Red	Yellow	Red	Yellow	Red	Green	Green	Green	White	Green*
Ni-Cr/Cu-Ni (E)		—			—			—		Violet	White	Violet*
Nicrisil/Nisil (N)	Orange	Blue	Orange	Orange	Red	Orange		—		Pink	White	Pink
Pt/Pt-Rh (R and S)	White	Blue	Green	Black	Red	Green	Red	White	White	Orange	White	Orange*
Pt-Rh/Pt-Rh (B)		—			—			—		Grey	White	Grey*
Cu/Cu-Ni (T)	White	Blue	Blue	Blue	Red	Blue	Red	Brown	Brown	Brown	White	Brown*
Fe/Con (J)	Yellow	Blue	Black	White	Red	Black	Red	Blue	Blue	Black	White	Black*
	* Case Blue for intrinsically safe circuits											
Fe/Con (DIN 43710)		—			—		<b>DIN 43710</b>				—	
							Blue/Red	Blue	Blue			

**Table 5.1 Thermocouple Compensating Cable**

## ...5 ELECTRICAL INSTALLATION

### 5.2.2 Voltage and Current – Fig. 5.5 (B, C and F)

**Note.** Input impedances:

Low voltage (mV)	>10MΩ
Voltage	>10MΩ
Current (mA)	100Ω

### 5.2.3 2-wire Transmitter Input – Fig. 5.5 (D)

Power for the transmitter is supplied by terminal 6.

**Note.** The voltage across terminals 4 and 6 is 20V (nominal). This is due to internal voltage drops across a shunt resistor and measurement circuitry.

### 5.2.4 Thermocouple – Fig. 5.5 (E)

Use the correct compensating cable between the thermocouple and the terminals – see Table 5.1 (previous page).

An automatic cold junction (ACJC) is incorporated but an independent cold (reference) junction may be used.

### 5.2.5 Resistance Thermometer (RTD) – Fig. 5.5 (G and H)

If long leads are necessary it is preferable to use a 3-lead resistance thermometer.

If 2-lead resistance thermometers are used each input must be calibrated to take account of the lead resistance.

### 5.2.6 Logic Inputs – Fig. 5.5 (A)

The two logic inputs accept either volt-free (switch) or TTL (5V) input types and can be used for remote switching of many recorder functions, e.g. chart stop/go, alarm acknowledgment, totalizer reset etc. – see Section 3.11.

### 5.2.7 Analog Output – Fig. 5.5 (A)

### 5.2.8 Relay Output – Fig. 5.5 (A)

**Note.** Relay specification:

Type	single pole changeover
Voltage	250V AC 250V DC
Current	5A AC 5A DC
Loading (non inductive)	1250VA 50W
Isolation, contacts to earth	2kV RMS

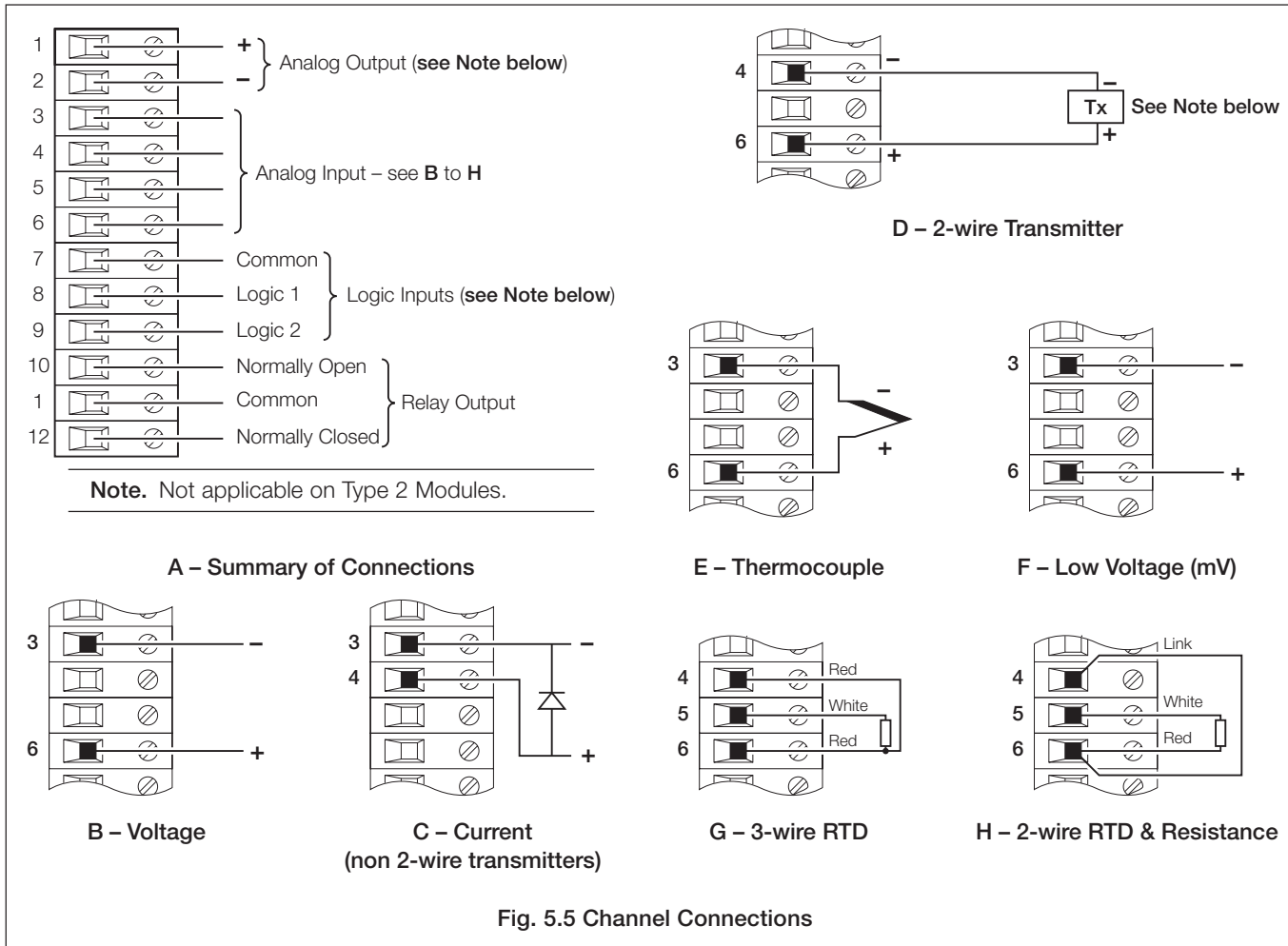

Fig. 5.5 Channel Connections

5.3 Module Connections

5.3.1 Standard I/O or Analog + Relay (Module Types 1, 2 and 7) – Fig. 5.5

The connections are the same as Channel connections to the main board. Refer to Section 5.2.

5.3.2 Four Relay Module (Module Type 3) – Fig. 5.6

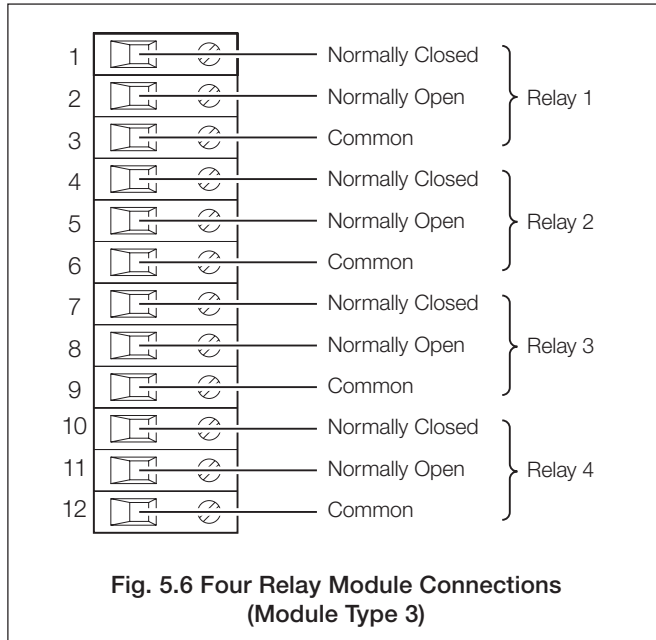

5.3.3 Eight Digital Inputs or Outputs (Module Types 4 and 5 respectively) – Figs. 5.7 and 5.8

A plug-in link is used to select the board's function; digital inputs or digital outputs – see Fig. 5.7. The maximum current drain from each TTL output must not exceed 5mA.

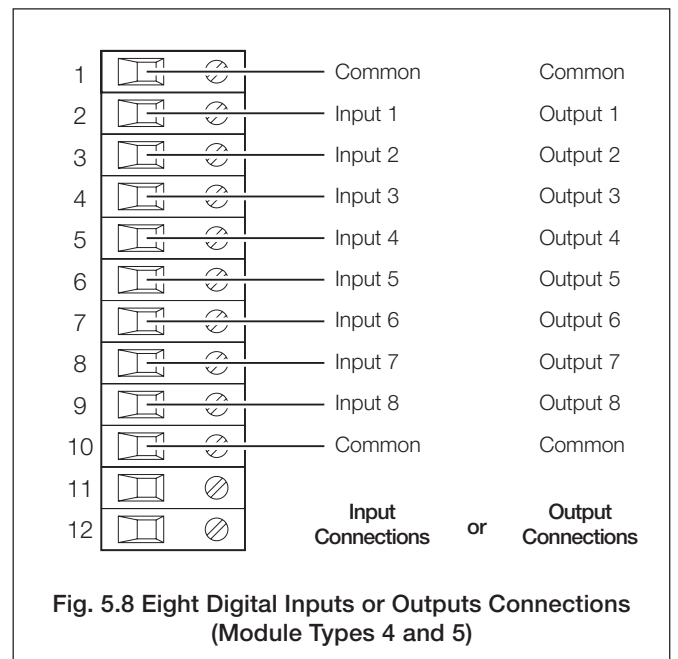
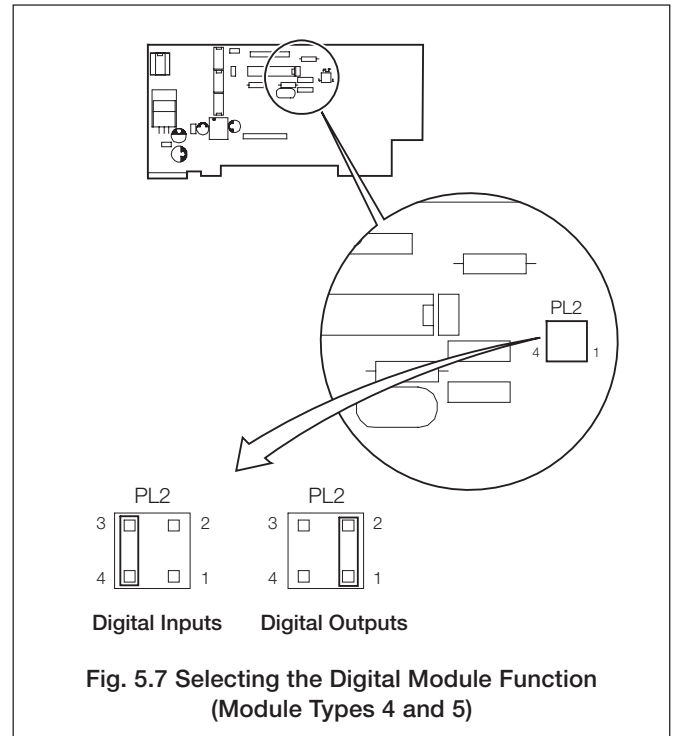

5.4 Power Supply Selection and AC Connections – Fig. 5.9

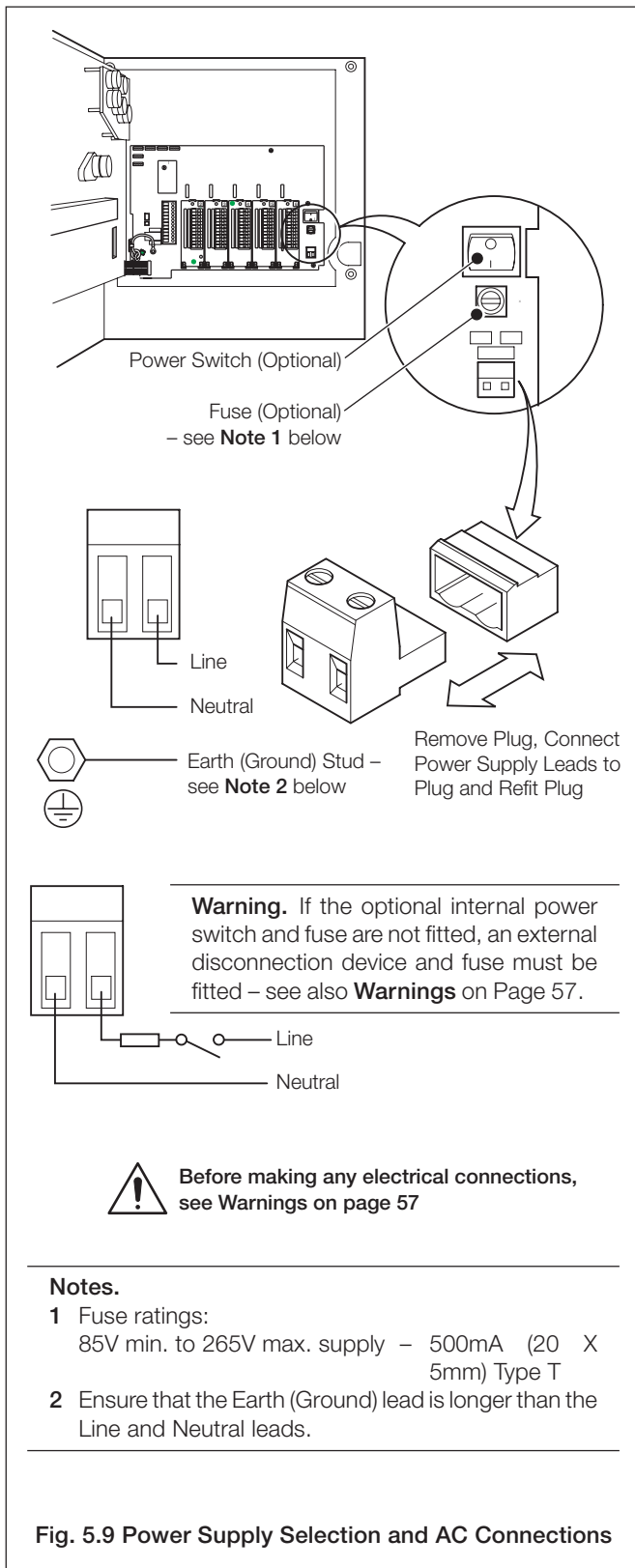

Fig. 5.9 Power Supply Selection and AC Connections

## 6 FAULT DIAGNOSIS

Symptom	Possible Cause	Action
Recorder does not power up	a) Internal fuse (if fitted) is blown b) Internal power switch (if fitted) is OFF c) Power supply connections are incorrect	a) Check wiring, rectify fault and replace fuse b) Turn power switch ON c) Check connections
Chart does not appear to move	a) Very slow chart duration selected – see Section 3.4 b) <b>Stop Chart Source</b> selected – see Section 3.4	a) Select required chart duration in <b>Common Configuration</b> – see Section 3.4 b) Set <b>Stop Chart Source</b> to <b>None</b> – see Section 3.4
Pens in recording position but do not drop onto paper	<b>Stop Chart Source</b> selected – see Section 3.4	Set <b>Stop Chart Source</b> to <b>None</b> – see Section 3.4
Red pen does not move beyond 94% position on chart	When real-time event pen is fitted the red pen cannot go beyond 94% to prevent pens clashing	Use chart range that prevents the need to go beyond 94% of maximum on chart
Pen lift key on front panel does not work	Pen lift key is disabled	Set <b>Pen Lift Enable</b> to <b>YES</b> – see Section 3.4
Pens do not remain lifted when pen lift key is used	Auto pen drop feature is enabled	Set <b>Auto Pen Drop</b> to <b>NO</b> – see Section 3.4
Analog inputs are slow to respond	A large filter time has been set	Set <b>Pen X Filter</b> to a value that gives the required response – see Section 3.5
Time or date incorrect	Not set for correct local time	Set correct time and date – see Section 3.12
Totalizers cannot be reset by the Operator	Totalizer reset function is not enabled	Set <b>Totalizer Reset</b> to <b>YES</b> – see Section 3.4
External relays connected to relays in instrument fail to de-energize	Arc suppression capacitors are provided across the relay contacts and capacitor leakage current may be sufficient to prevent an external relay from de-energizing	Remove the arc suppression components: <ul style="list-style-type: none"> <li>• R13 and R14 on mainboard</li> <li>• R1 and R7 on standard I/O and analog relay module</li> <li>• IC3 to IC10 on 4 relay module</li> </ul>

Table 6.1 Fault Diagnosis

## 7 SPARES AND ACCESSORIES

Item	Part No.
<b>Pen Capsules</b> (pack of 3)	
Black .....	C1900/0119
Blue .....	C1900/0120
Red .....	C1900/0121
Green .....	C1900/0122
Violet* .....	C1900/0123
<b>Pen Arm Assemblies</b>	
ER/C Type Chart (J or R in Code Number) – Standard Pen .....	C1900/0076
ER/C Type Chart (J or R in Code Number) – Event Pen .....	C1900/0078
PX105 and PXR105 Type Chart (K or S in Code Number) – Standard Pen .....	C1900/0075
PX105 and PXR105 Type Chart (K or S in Code Number) – Event Pen .....	C1900/0077
<b>Fuses</b>	
100 to 240V .....	B11069 (500mA)

\*True time line event option only.

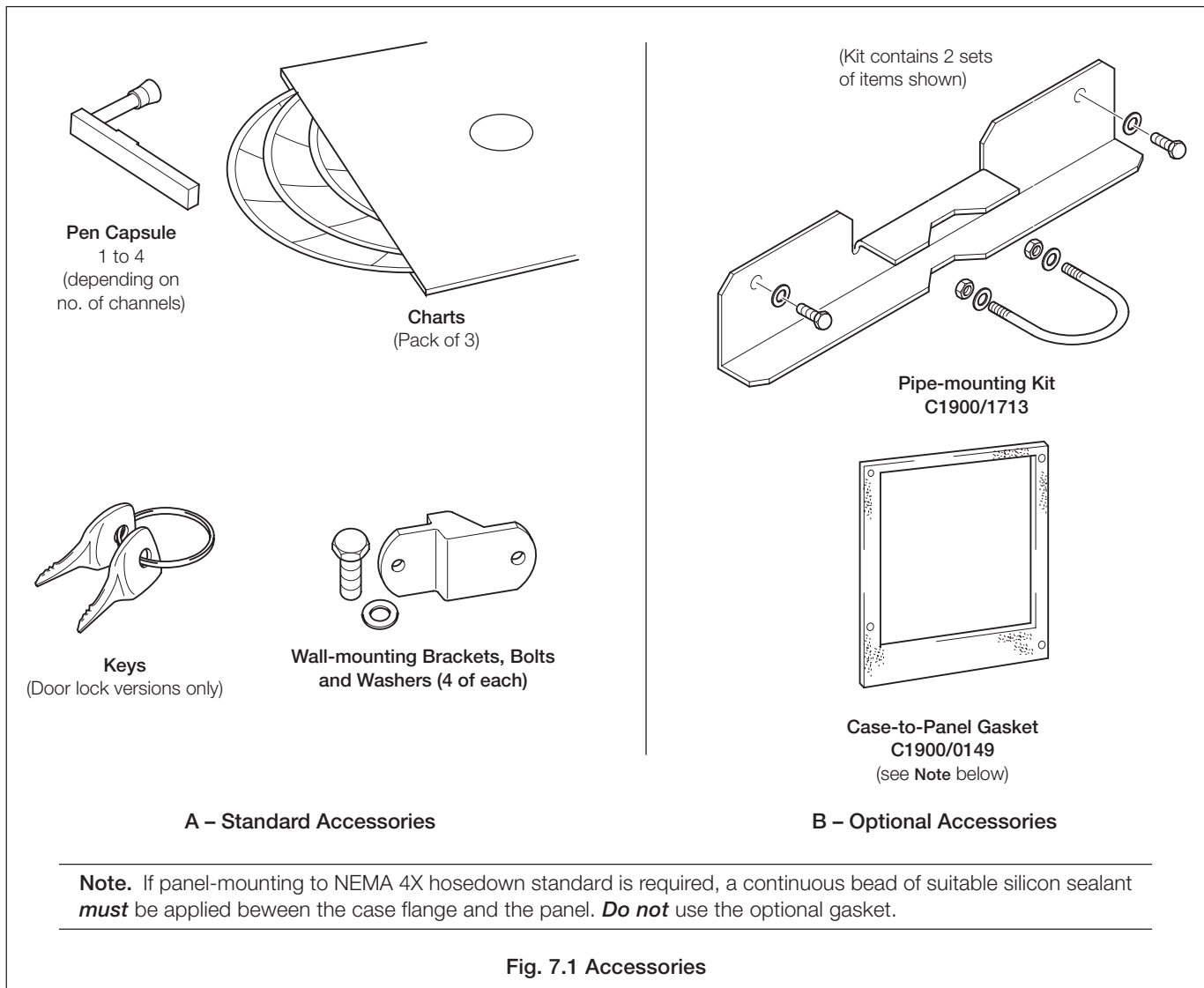

## 8 SPECIFICATION

### Summary

1, 2, 3 or 4 pens

10 in. or 105mm chart size

Standard I/O with each pen includes:

analog input, analog output, transmitter power supply,  
relay output and 2 digital inputs

### Specification

#### Construction

Size	15.23 in. (h) x 15.04 in. (w) x 5.57 in. (d) (386.8 x 382.0 x 135mm)
Weight	18lb (8.2kg)
Case material	Glassfiber-filled reinforced polyester
Window material	Polycarbonate or glass
Door latch	High-compression with optional lock

#### Environmental

Operational temperature range	0° to 55°C (32° to 130°F)
Operational humidity range	5 to 95%RH (non-condensing) 5 to 80%RH (chart only)
Case sealing	NEMA 3 (IP54) NEMA 4X (IP66) (optional)

#### Installation

Mounting options	Panel, wall or pipe
Terminal type	Screw
Wire size (max)	14 AWG (I/O), 12 AWG (power)

#### Operation and Configuration

Programming method	Via front panel keys
Security	Password-protected menus

#### Safety

General safety	EN61010
Installation category	II
Pollution degree	2
Dielectric	500V DC (channel/channel) 2kV DC (channel/ground)
Memory protection	Nonvolatile FRAM
Approvals	CE CSA General Safety (pending) UL General Safety (pending)

#### Power Supply

Voltage	90V min. to 265V max. AC, 50/60Hz
Consumption	<30 VA (typical for full spec. unit)
Line interruption	Up to 60ms

## ...8 SPECIFICATION

### Process Inputs and Outputs

#### General

Noise Rejection	Common mode >120dB at 50/60Hz Normal (series) mode >60dB at 50/60Hz
CJC rejection ratio	<0.05°C/°C (0.1°F/°F)
Sensor break protection	Upscale or downscale drive
Out of range detection	0 to 100% of engineering span
Temperature stability	<0.02% of reading/°C (0.04% of reading/°F) or 1μV/°C
Long-term drift	<0.01% of reading or 10μV annually
Input impedance	>10MΩ (mV and V inputs) 39Ω (mA input)

#### Analog Inputs

Signal types	mV, V, mA, Ω
Thermocouple types	B, E, J, K, N, R, S, T
Resistance thermometer	Pt 100
Other linearizations	$x^{1/2}$ , $x^{3/2}$ , $x^{5/2}$ , linear
Sample interval	250ms per channel
Dielectric	500V DC channel/channel
Digital Filter	0 to 60s (programmable)

#### 2-Wire Transmitter Power Supplies

Number	1 per channel
Voltage	24V DC nominal
Drive	Up to 25mA
Isolation	500V DC channel-to-channel

#### Analog Outputs

Type	4 to 20mA
Accuracy	±0.1%
Maximum load	750Ω
Dielectric	500V DC

#### Relay Outputs

Type	SPDT
Rating (with non-inductive load)	5A at 115/230V AC

#### Digital Inputs

Type	TTL or volt-free
Minimum pulse	250ms
Dielectric	500V DC between modules, no isolation within module

#### Digital Outputs

Type	5V TTL
Rating	5mA per output
Dielectric	500V DC between modules, no isolation within module

#### Serial Communications

Connections	RS485, 4-wire
Protocol	Modbus RTU

### Analog Input Performance

Type	Range Low	Range High	Minimum Span	Accuracy
mV	0	150	5	±0.1% reading or 10μV
V	0	5	0.1	±0.1% reading or 20mV
mA	0	50	1	±0.2% reading or 0.2μA
Ohms (low)	0	750	20	±0.2% reading or 0.1Ω
Ohms (high)	0	10k	400	±0.5% reading or 10Ω

Type	°C		°F		Accuracy (excluding CJC)
	Range Low	Range High	Range Low	Range High	
B	-18	1800	0	3270	±2.0°C (above 200°C) (3.6°F [above 434°F])
E	-100	900	-140	1650	±0.5°C (0.9°F)
J	-100	900	-140	1650	±0.5°C (0.9°F)
K	-100	1300	-140	2350	±0.5°C (0.9°F)
N	-200	1300	-325	2350	±0.5°C (0.9°F)
R	-18	1700	0	3000	±1.0°C (above 300°) (1.8°F [above 572°F])
S	-18	1700	0	3000	±1.0°C (above 200°C) (1.8°F [above 434°F])
T	-250	300	-400	550	±0.5°C (0.9°F)
PT100	-200	600	-325	1100	±0.5°C (0.9°F)

## Recording System

### Pens

Number	1, 2, 3, or 4 (red, green, blue, black)
Response	7 seconds (full scale)
Resolution	0.1% steps
Pen lift	Motor-driven, with optional autodrop

### Event Pens

Standard	3-position event recording on any channel
Real time	3-position event recording on the same time line as Pen 1

### Chart

Chart size	10 in. or 105mm
Chart speed	1 to 167 hours or 7 to 32 days per revolution

## Graphical Display Panels

### Displays

Number	1 (1 or 2 pens) or 2 (3 or 4 pens)
Type	High contrast 128 x 64 STN dot matrix LCD (graphics) module
Status indicators	Indicate channel number on display
Alarm indicators	Indicate channel with active alarms

### Panel keys

Function	Programming access, increment/decrement, pen lift and menu key
----------	--

## Alarms and Logic

### Alarms

Number	4 per channel
Type	High/low process, fast/slow rate of change, time delay
Adjustments	Hysteresis, time delay

### Logic Equations

Number	4
Function	OR, AND
Inputs	Alarm states, digital inputs, totalizers, logic
Outputs	Relays, digital outputs, chart stop, alarm acknowledge

## Advanced Software Functions

### Totalizers

Number	Up to 4
Size	99,999,999 max.
Output	External counter driver, 'wrap' pulse signal
Totalizer log	Max. 21 entries per totalizer

### Math

Number of equations	4
Type	+, -, x, ÷, low & high select, maximum, minimum, average, mass flow, RH

### Timers

Number	2
Type	Real-time clock driven event, adjustable duration
Output	Relay, digital output, logic equation

## EMC

### Emissions and Immunity

Meets requirements of:
EN50081-2
EN50082-2
EN61326 for an industrial environment
CE Mark

## Option Module Types

Module Type	I/O Per Module							Max. No. Per Instrument
	Analog I/P	Analog O/P	Trans. PSU	Relays	Digital I/P	Digital O/P	Comms.	
Standard I/O	1	1	1	1	2			4
4 relays				4				2
8 digital I/P					8			3
8 digital O/P						8		3
RS485 comms.							1	1

SS/C1300 Issue 1

# APPENDIX 1 – SIGNAL SOURCES

Source	Description
None	No source required
Pen 1 ⋮ Pen 4	Process variable assigned to Pen 1 Process variable assigned to Pen 2 Process variable assigned to Pen 3 Process variable assigned to Pen 4
Math Block 1 ⋮ Math Block 4	Result of Math Block 1 Result of Math Block 2 Result of Math Block 3 Result of Math Block 4 } Available only if Math software option enabled by installation of appropriate software key
Constant 1 ⋮ Constant 8	} Available only if Math software option enabled by installation of appropriate software key
Input 1 ⋮ Input 6	} Analog inputs 1 to 6
Alarm A1 ⋮ Alarm D1	Alarm A Alarm B Alarm C Alarm D } Channel 1 Alarms (if applicable)
Alarm A2 ⋮ Alarm D2	Alarm A Alarm B Alarm C Alarm D } Channel 2 Alarms (if applicable)
Alarm A3 ⋮ Alarm D3	Alarm A Alarm B Alarm C Alarm D } Channel 3 Alarms (if applicable)
Alarm A4 ⋮ Alarm D4	Alarm A Alarm B Alarm C Alarm D } Channel 4 Alarms (if applicable)
Dig Input Main 1 ⋮ Dig Input Mod6 8	Digital input module 1 input 1 Digital input module 6 input 8 Available only if digital input module fitted
Total 1 Count Total 1 Wrap ⋮ Total 4 Count Total 4 Wrap	Totalizer 1 external counter drive Wrap around on totalizer 1 Totalizer 4 external counter drive Wrap around on totalizer 4 } Available only if Totalizer software option enabled by installation of appropriate software key
Equation 1 ⋮ Equation 8	Programmable logic equation 1 Programmable logic equation 8
Timer 1 ⋮ Timer 2	Real time event 1 Real time event 2 } Available only if Timers software option enabled by installation of appropriate software key

Table A1.1 Signal Sources

# INDEX

## A

AC Connections .....	62
Accessories .....	64
Adjusting and Storing a Parameter Value .....	6
Alarms	
Configuration .....	29
Fast Rate .....	30
High and Low Process .....	29
Icons .....	7
Set Point Adjustment .....	16
Enable .....	20
Slow Rate .....	30
Time Hysteresis .....	29
Trip Level .....	32
Type .....	31
Analog Output	
Configuration .....	43
Electrical Range High .....	44
Electrical Range Low .....	44
Range High .....	44
Range Low .....	44
Source .....	43
Auto Pen Drop .....	18
Autoscroll .....	9

## B

Broken Sensor Protection Drive .....	27
--------------------------------------	----

## C

Calibration .....	51
Offset .....	50
Pen High Value .....	51
Pen Low Value .....	51
Span .....	50
Channel Connections .....	60
Channel Tag .....	24
Channel Units .....	25
Chart Duration .....	18
Chart Range High .....	26
Chart Range Low .....	26
Configuration	
Analog Output .....	43
Backing Up and Restoring .....	52
Channel .....	22
Common .....	18
Digital I/O .....	41
Logic Equation .....	45
Relay .....	40
Security Code .....	17, 18
System Clock .....	48
Configuration Backup Utility .....	52, 53

## D

Decimal Point .....	25
Digital Input	
Polarity .....	42
Digital Input and Output	
Configuration .....	41
Digital Output	
Polarity .....	42
Source .....	42
Display Screen .....	6
Brightness .....	21
Contrast .....	21

## E

Electrical Input Range High .....	25
Electrical Input Range Low .....	25
Engineering Range High .....	26
Engineering Range Low .....	26
Enter/Edit User-defined Information .....	6
Environmental Requirements .....	54
Error Messages	
Input .....	7
Start-up .....	5

## F

Fault Detection Level Percentage .....	27
Fault Diagnosis .....	63
Fitting a Chart .....	3
Fitting the Pen Capsule(s) .....	2

## H

Hysteresis .....	32
------------------	----

## I

Input (Pen) Channel	
Display	
Configure .....	19
Dual .....	11
Separate .....	10
Separate and Dual .....	11
Input Type .....	24
Selecting .....	59
Input/Output Modules	
Identification .....	58

## L

Line Rejection .....	19
Linearizer Type .....	24
Logic Equation Configuration .....	45

---

## ...INDEX

---

### M

Making a Selection .....	6
Module Positions and Functions .....	58
Mounting .....	54

### O

Operator Keys .....	6
Other Channels Display	
Configure .....	20
Overall Dimensions .....	54

### P

Panel Mounting .....	56
Pen Filter .....	27
Pen Function .....	49
Pen In Source .....	28
Pen In Tag .....	28
Pen Lift Enable .....	18
Pen Off Tag .....	28
Pen Out Source .....	28
Pen Out Tag .....	28
Pen Source .....	49
Power Supply Selection .....	62

### R

Raise/Lower Pens .....	6
Relays	
Configuration .....	40
Polarity .....	40
Source .....	40

### S

Security Code -See Configuration: Security Code	
Siting .....	54
Software key .....	5
Stop Chart .....	18
System Clock Configuration .....	48

### T

Terminal Block	
Removing .....	57
Thermocouple Compensating Cable .....	59
Time Hysteresis .....	32
Totalizers	
Configuration .....	33
Control .....	15
Count Direction .....	36
Count Rate .....	33, 37
Calculating Manually .....	34
Cut Off .....	37
Display	
Configure .....	20
Dual + Flow Rate .....	13
Dual Total .....	13
Rate with Total .....	12
Separate .....	12
Total with Rate .....	13
Log .....	14
Predetermined Value .....	37
Preset Value .....	37
Reset .....	14, 21
Day .....	38
Source .....	38
Time .....	38
Run Source .....	39
Secure Total .....	39
Reset .....	39
Source .....	35
Tag .....	36
Units .....	36
Wrap .....	38

### W

Wall-/Pipe-Mounting .....	55
---------------------------	----

# INSTALLATION RECORD

## Position 1

Module Type (Tick Box)  1  2  3

1	+	
2	-	
3		<p>Link Positions (Tick Boxes)</p>
4		
5		
6		
7	C	
8	L1	
9	L2	
10	NO	
1	C	
12	NC	

## Position 2

Module Type (Tick Box)  1  2  3

1	+	
2	-	
3		<p>Link Positions (Tick Boxes)</p>
4		
5		
6		
7	C	
8	L1	
9	L2	
10	NO	
1	C	
12	NC	

## Position 3

Module Type (Tick Box)  1  2  3

1	+	
2	-	
3		<p>Link Positions (Tick Boxes)</p>
4		
5		
6		
7	C	
8	L1	
9	L2	
10	NO	
1	C	
12	NC	

\* Not applicable on Module Type 2

\* Not applicable on Module Type 2

## Position 4

Module Type (Tick Box)  1  2  3  4  5  6  7

1	+	
2	-	
3		<p>Link Positions (Tick Boxes)</p>
4		
5		
6		
7	C	
8	L1	
9	L2	
10	NO	
1	C	
12	NC	

\* Not available on Module Type 2

4  5  6  7  8  9  10  11  12  13  14  15  16  17  18  19  20  21  22  23  24  25  26  27  28  29  30  31  32  33  34  35  36  37  38  39  40  41  42  43  44  45  46  47  48  49  50  51  52  53  54  55  56  57  58  59  60  61  62  63  64  65  66  67  68  69  70  71  72  73  74  75  76  77  78  79  80  81  82  83  84  85  86  87  88  89  90  91  92  93  94  95  96  97  98  99  100  101  102  103  104  105  106  107  108  109  110  111  112  113  114  115  116  117  118  119  120  121  122  123  124  125  126  127  128  129  130  131  132  133  134  135  136  137  138  139  140  141  142  143  144  145  146  147  148  149  150  151  152  153  154  155  156  157  158  159  160  161  162  163  164  165  166  167  168  169  170  171  172  173  174  175  176  177  178  179  180  181  182  183  184  185  186  187  188  189  190  191  192  193  194  195  196  197  198  199  200  201  202  203  204  205  206  207  208  209  210  211  212  213  214  215  216  217  218  219  220  221  222  223  224  225  226  227  228  229  230  231  232  233  234  235  236  237  238  239  240  241  242  243  244  245  246  247  248  249  250  251  252  253  254  255  256  257  258  259  260  261  262  263  264  265  266  267  268  269  270  271  272  273  274  275  276  277  278  279  280  281  282  283  284  285  286  287  288  289  290  291  292  293  294  295  296  297  298  299  300  301  302  303  304  305  306  307  308  309  310  311  312  313  314  315  316  317  318  319  320  321  322  323  324  325  326  327  328  329  330  331  332  333  334  335  336  337  338  339  340  341  342  343  344  345  346  347  348  349  350  351  352  353  354  355  356  357  358  359  360  361  362  363  364  365  366  367  368  369  370  371  372  373  374  375  376  377  378  379  380  381  382  383  384  385  386  387  388  389  390  391  392  393  394  395  396  397  398  399  400  401  402  403  404  405  406  407  408  409  410  411  412  413  414  415  416  417  418  419  420  421  422  423  424  425  426  427  428  429  430  431  432  433  434  435  436  437  438  439  440  441  442  443  444  445  446  447  448  449  450  451  452  453  454  455  456  457  458  459  460  461  462  463  464  465  466  467  468  469  470  471  472  473  474  475  476  477  478  479  480  481  482  483  484  485  486  487  488  489  490  491  492  493  494  495  496  497  498  499  500  501  502  503  504  505  506  507  508  509  510  511  512  513  514  515  516  517  518  519  520  521  522  523  524  525  526  527  528  529  530  531  532  533  534  535  536  537  538  539  540  541  542  543  544  545  546  547  548  549  550  551  552  553  554  555  556  557  558  559  560  561  562  563  564  565  566  567  568  569  570  571  572  573  574  575  576  577  578  579  580  581  582  583  584  585  586  587  588  589  590  591  592  593  594  595  596  597  598  599  600  601  602  603  604  605  606  607  608  609  610  611  612  613  614  615  616  617  618  619  620  621  622  623  624  625  626  627  628  629  630  631  632  633  634  635  636  637  638  639  640  641  642  643  644  645  646  647  648  649  650  651  652  653  654  655  656  657  658  659  660  661  662  663  664  665  666  667  668  669  670  671  672  673  674  675  676  677  678  679  680  681  682  683  684  685  686  687  688  689  690  691  692  693  694  695  696  697  698  699  700  701  702  703  704  705  706  707  708  709  710  711  712  713  714  715  716  717  718  719  720  721  722  723  724  725  726  727  728  729  730  731  732  733  734  735  736  737  738  739  740  741  742  743  744  745  746  747  748  749  750  751  752  753  754  755  756  757  758  759  760  761  762  763  764  765  766  767  768  769  770  771  772  773  774  775  776  777  778  779  780  781  782  783  784  785  786  787  788  789  790  791  792  793  794  795  796  797  798  799  800  801  802  803  804  805  806  807  808  809  810  811  812  813  814  815  816  817  818  819  820  821  822  823  824  825  826  827  828  829  830  831  832  833  834  835  836  837  838  839  840  841  842  843  844  845  846  847  848  849  850  851  852  853  854  855  856  857  858  859  860  861  862  863  864  865  866  867  868  869  870  871  872  873  874  875  876  877  878  879  880  881  882  883  884  885  886  887  888  889  890  891  892  893  894  895  896  897  898  899  900  901  902  903  904  905  906  907  908  909  910  911  912  913  914  915  916  917  918  919  920  921  922  923  924  925  926  927  928  929  930  931  932  933  934  935  936  937  938  939  940  941  942  943  944  945  946  947  948  949  950  951  952  953  954  955  956  957  958  959  960  961  962  963  964  965  966  967  968  969  970  971  972  973  974  975  976  977  978  979  980  981  982  983  984  985  986  987  988  989  990  991  992  993  994  995  996  997  998  999  1000  1001  1002  1003  1004  1005  1006  1007  1008  1009  1010  1011  1012  1013  1014  1015  1016  1017  1018  1019  1020  1021  1022  1023  1024  1025  1026  1027  1028  1029  1030  1031 <

**Position 5**

Module Type (Tick Box)  2

Analog Output *	1 +	
	2 -	
Analog Input	3	
	4	
	5	
	6	
Logic Inputs *	7 C	
	8 L1	
	9 L2	
Relay Output	10 NO	
	1 C	
	12 NC	

3

Relay Output 1	1 NC
	2 NO
	3 C
Relay Output 2	4 NC
	5 NO
	6 C
Relay Output 3	7 NC
	8 NO
Relay Output 4	9 C
	10 NC
	1 NO
	12 C

4  5

Logic I/Ps (Type 4) or Logic O?ps (Type 5)	1 C
	2 1
	3 2
	4 3
	5 4
	6 5
	7 6
	8 7
	9 8
	10 C

Link Positions (Tick Box) Type 4 Type 5

\* Not available on Module Type 2

**Position 6**

Module Type (Tick Box)  2

Analog Output *	1 +	
	2 -	
Analog Input	3	
	4	
	5	
	6	
Logic Inputs *	7 C	
	8 L1	
	9 L2	
Relay Output	10 NO	
	1 C	
	12 NC	

4  5

Logic I/Ps (Type 4) or Logic O/Ps (Type 5)	1 C
	2 1
	3 2
	4 3
	5 4
	6 5
	7 6
	8 7
	9 8
	10 C

Link Positions (Tick Box) Type 4 Type 5

\* Not available on Module Type 2

- Operating Level
- Alarm Setpoints
- Security Code
- Common
- Channels
- Alarms
- Relays
- Digital I/O

**Common**  
Section 3.4 Page 18

Chart Duration	24 hours
Stop Chart Srce	None
Auto Pen Drop	YES
Pen Lift Enable	YES
Config Password	0000
Line Rejection	50 Hz
Pen Ch Display	Separate
Totals Display	Separate
Other Ch Display	NO
Alarm Adjust	NO
Totalizer Reset	NO
Contrast 1	100
Brightness 1	100

**Channels**  
Section 3.5 Page 22

Select Channel	Pen 1
Pen 1 Tag	Input 1 Edit>
Pen 1 Input Type	High Ohm
Pen 1 lin. Type	Type K
Pen 1 Units	18 gal/h (Imp)
Pen 1 Elect. Hi	20.00 mA
Pen 1 Elect. Lo	4.00 mA
Pen 1 Dec. Point	XXXX.X
Pen 1 Eng. Hi	2500.0 gal/h
Pen 1 Eng. Lo	0000.0 gal/h
Pen 1 Chart Hi	2500.0 gal/h
Pen 1 Chart Lo	0000.0 gal/h
Pen 1 Brk Sensor	Downscale
Pen 1 Fault Lev.	10 %
Pen 1 Filter	Off

**Alarms**  
Section 3.6 Page 29

Select Alarm	A1
A1 Type	Off
A1 Trip	0000.0 gal/h
A1 Hysteresis	0000.0 gal/h
A1 Time Hyst	0000 Secs

**Totalizers**  
Section 3.7 Page 33

Select Totalizer	T1 Configuration
Tot 1 Source	Pen 1
Tot 1 Tag	Totalizer 1 Edit>
Tot 1 Count Dir	Up
Tot 1 Units	18 gal/h (Imp)
Tot 1 Count Rate	00.0000 Manual
Tot 1 Cut Off	5000.0 gal/h
Tot 1 Preset	000005000 gal/h
Tot 1 Predet	000004500 gal/h
Tot 1 Wrap	YES
Tot 1 Reset Srce	Timed
Tot 1 Reset Days	Monday
Tot 1 Reset Hour	00:00
Tot 1 Run Source	None
Tot 1 Log Enable	None

**Relays**  
Section 3.8 Page 40

Select Relay	Relay 1.1
Relay 1.1 Source	Alarm A1
Rly 1.1 Polarity	Negative

**Digital I/O**  
Section 3.9 Page 41

Select Dig I/O	Output 6.1
Dout 6.1 Source	Alarm A1
Dout6.1 Polarity	Negative
OR	
Select Dig I/O	Input 1.x
Din 1.x Polarity	Negative

**Analog Output**  
Section 3.10 Page 43

Select Output	Analog Output 1
O/P1 Source	Pen 1
O/P1 Range High	2500.0 gal/h
O/P1 Range Low	0000.0 gal/h
O/P1 Elect High	020.0 mA
O/P1 Elect Low	004.0 mA

**Modbus**  
Available only if enabled by installation of appropriate software key. Refer to Modbus Supplementary Manual IM/C1300-MOD

**Math Blocks**  
Available only if enabled by installation of appropriate software key. Refer to Advanced Software Options Supplementary Manual IM/C1300-ADV

**Logic Equations**  
Section 3.11 Page 45

Select Equation	Equation 1
Equation 1.1	Alarm A1 Invert>
Equation 1.2	AND
Equation 1.3	NOT Alarm B1 Invert>
Equation 1.4	OR
Equation 1.5	Alarm C1 Invert>
Equation 1.6	XOR
Equation 1.7	None

**Timers**  
Available only if enabled by installation of appropriate software key. Refer to Advanced Software Options Supplementary Manual IM/C1300-ADV

**Clock**  
Section 3.12 Page 48

System Time	Wednesday 26th May 2004 15:28:59
Set Clock	YES
Set Year	2004
Set Month	May
Set Date	26th
Set Day	Wednesday
Set Hour	15:00
Set Minute	15:28
Update - NO	Wednesday 26th May 2004 15:29:00

**Pen Function**  
Section 3.13 Page 49

Select Pen	Pen 1
Pen 1 Function	Trend
Pen 1 Source	Input 1

**Calibration**  
Section 3.14 Page 50

Select Cal	Pen 1 Input Cal
Reset Pen 1 Cal	-9999.9 gal/h
Pen 1 Offset	-9999.9 gal/h
Pen 1 Span	1.0000
OR	
Select Cal	Pen 1 Chart Cal
Set Pen 1 High	0
Set Pen 1 Low	0

Anything other than Timed

Select Totalizer	T1 Secure Total
Secure Total 1	000000000 gal
T1 Secure Reset	NO

OR

# PRODUCTS & CUSTOMER SUPPORT

## Products

### Automation Systems

- *for the following industries:*
  - Chemical & Pharmaceutical
  - Food & Beverage
  - Manufacturing
  - Metals and Minerals
  - Oil, Gas & Petrochemical
  - Pulp and Paper

### Drives and Motors

- *AC and DC Drives, AC and DC Machines, AC Motors to 1kV*
- *Drive Systems*
- *Force Measurement*
- *Servo Drives*

### Controllers & Recorders

- *Single and Multi-loop Controllers*
- *Circular Chart and Strip Chart Recorders*
- *Paperless Recorders*
- *Process Indicators*

### Flexible Automation

- *Industrial Robots and Robot Systems*

### Flow Measurement

- *Electromagnetic Flowmeters*
- *Mass Flow Meters*
- *Turbine Flowmeters*
- *Flow Elements*

### Marine Systems & Turbochargers

- *Electrical Systems*
- *Marine Equipment*
- *Offshore Retrofit and Refurbishment*

### Process Analytics

- *Process Gas Analysis*
- *Systems Integration*

### Transmitters

- *Pressure*
- *Temperature*
- *Level*
- *Interface Modules*

### Valves, Actuators and Positioners

- *Control Valves*
- *Actuators*
- *Positioners*

### Water, Gas & Industrial Analytics Instrumentation

- *pH, Conductivity, and Dissolved Oxygen Transmitters And Sensors*
- *Ammonia, Nitrate, Phosphate, Silica, Sodium, Chloride, Fluoride, Dissolved Oxygen and Hydrazine Analyzers.*
- *Zirconia Oxygen Analyzers, Katharometers, Hydrogen Purity and Purge-gas Monitors, Thermal Conductivity*

## Customer Support

We provide a comprehensive after sales service via a Worldwide Service Organization. Contact one of the following offices for details on your nearest Service and Repair Centre.

### United Kingdom

ABB Limited  
Tel: +44 (0)1480 475321  
Fax: +44 (0)1480 217948

### United States of America

ABB Inc.  
Tel: +1 215-674-6000  
Fax: +1 215-674-7183

#### Client Warranty

Prior to installation, the equipment referred to in this manual must be stored in a clean, dry environment, in accordance with the Company's published specification.

Periodic checks must be made on the equipment's condition. In the event of a failure under warranty, the following documentation must be provided as substantiation:

1. A listing evidencing process operation and alarm logs at time of failure.
2. Copies of all storage, installation, operating and maintenance records relating to the alleged faulty unit.

**ABB** has Sales & Customer Support expertise in over 100 countries worldwide

[www.abb.com](http://www.abb.com)

The Company's policy is one of continuous product improvement and the right is reserved to modify the information contained herein without notice.

Printed in UK (10.04)

©ABB 2004



**ABB Limited**

Howard Road, St. Neots  
Cambridgeshire,  
PE19 8EU UK  
Tel: +44 (0)1480 475321  
Fax: +44 (0)1480 217948

**ABB Inc.**

125 E. County Line Road  
Warminster,  
PA 18974 USA  
Tel: +1 215-674-6000  
Fax: +1 215-674-7183