

Use of Instructions



Warning.

An instruction that draws attention to the risk of injury or death.



Note.

Clarification of an instruction or additional information.



Caution.

An instruction that draws attention to the risk of damage to the product, process or surroundings.



Information.

Further reference for more detailed information or technical details.

Although **Warning** hazards are related to personal injury, and **Caution** hazards are associated with equipment or property damage, it must be understood that operation of damaged equipment could, under certain operational conditions, result in degraded process system performance leading to personal injury or death. Therefore, comply fully with all **Warning** and **Caution** notices.

Information in this manual is intended only to assist our customers in the efficient operation of our equipment. Use of this manual for any other purpose is specifically prohibited and its contents are not to be reproduced in full or part without prior approval of Marketing Communications Department, ABB Ltd.

Health and Safety

To ensure that our products are safe and without risk to health, the following points must be noted:

1. The relevant sections of these instructions must be read carefully before proceeding.
2. Warning labels on containers and packages must be observed.
3. Installation, operation, maintenance and servicing must only be carried out by suitably trained personnel and in accordance with the information given.
4. Normal safety precautions must be taken to avoid the possibility of an accident occurring when operating in conditions of high pressure and/or temperature.
5. Chemicals must be stored away from heat, protected from temperature extremes and powders kept dry. Normal safe handling procedures must be used.
6. When disposing of chemicals ensure that no two chemicals are mixed.

Safety advice concerning the use of the equipment described in this manual or any relevant hazard data sheets (where applicable) may be obtained from the Company address on the back cover, together with servicing and spares information.

GETTING STARTED

This manual is divided into 5 sections which contain all the information needed to install, configure, commission and operate the COMMANDER 100. Each section is identified clearly by a symbol as shown below.

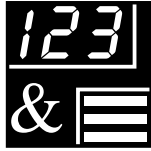

Displays and Function Keys

- Displays and function keys
- LED Indication
- Error Messages

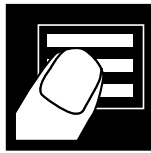

Operator Mode (Level 1)

- Operator menus for:
 - *Standard controller*
 - *Heat/Cool controller*
 - *Remote Set Point controller*
 - *Profile controller*
 - *Multiple Fixed Set Points controller*
- Auto tuning

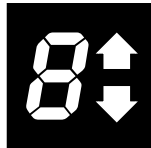

Set Up Mode (Levels 2, 3 and 4)

- Level 2 – Tuning
- Level 3 – Set Points
- Level 4 – Profile

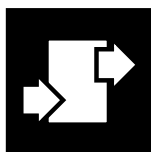

Configuration Mode (Levels 5 and 6)

- Level 5 – Basic hardware and control functions
- Level 6 – Ranges and passwords



Installation

- Siting
- Mounting
- Electrical connections

Symbol Identification and Section Contents

CONTENTS

| | | |
|----------|---|-----------|
| 1 | DISPLAYS AND FUNCTION KEYS | 3 |
| 1.1 | Introduction | 3 |
| 1.2 | Use of Function Keys | 4 |
| 1.3 | LED Alarms and Indicators | 5 |
| 1.4 | Error Messages | 6 |
| 2 | OPERATOR MODE | 7 |
| 2.1 | Introduction | 7 |
| 2.2 | Standard Controller | 8 |
| 2.3 | Heat/Cool Controller | 9 |
| 2.4 | Remote Set Point Controller | 10 |
| 2.5 | Profile Controller | 12 |
| 2.6 | Multiple Fixed Set Points Controller | 14 |
| 2.7 | Auto-tune | 16 |
| 3 | SET UP MODE | 18 |
| 3.1 | Introduction | 18 |
| 3.2 | Tuning (Level 2) | 18 |
| 3.3 | Set Points (Level 3) | 22 |
| 3.4 | Profile (Level 4) | 25 |
| 4 | CONFIGURATION MODE | 28 |
| 4.1 | Introduction | |
| 4.2 | Accessing the Configuration Mode | 28 |
| 4.3 | Basic Hardware and Configuration (Level 5) | 30 |
| 4.4 | Ranges and Passwords (Level 6) | 40 |
| 5 | INSTALLATION | 43 |
| 5.1 | Siting | 43 |
| 5.2 | Mounting | 45 |
| 5.3 | Electrical Connections | 47 |
| 5.4 | Relays, Arc Suppression, Digital Input and Output | 47 |



Information.

The fold-out page inside on the back cover of this manual shows all the frames in the programming levels. Space is provided on the page for writing the programmed setting or selection for each frame.

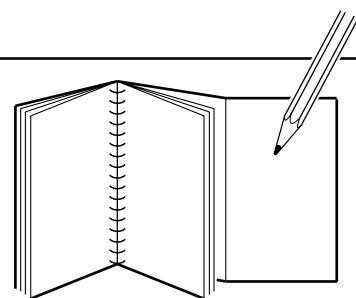

1 DISPLAYS AND FUNCTION KEYS

1.1 Introduction – Fig. 1.1

The COMMANDER 100 front panel displays, function keys and LED indicators are shown in Fig. 1.1.

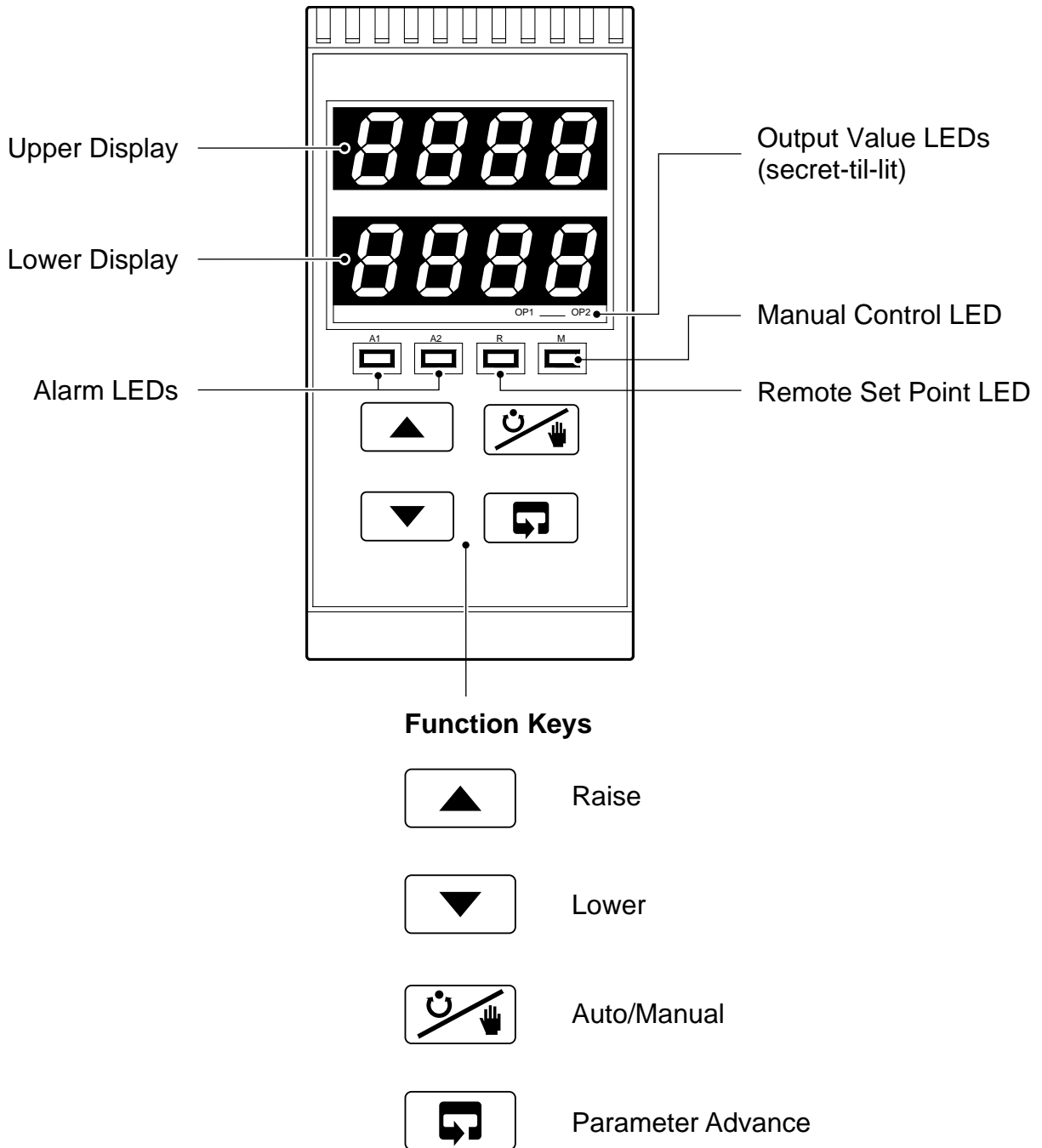
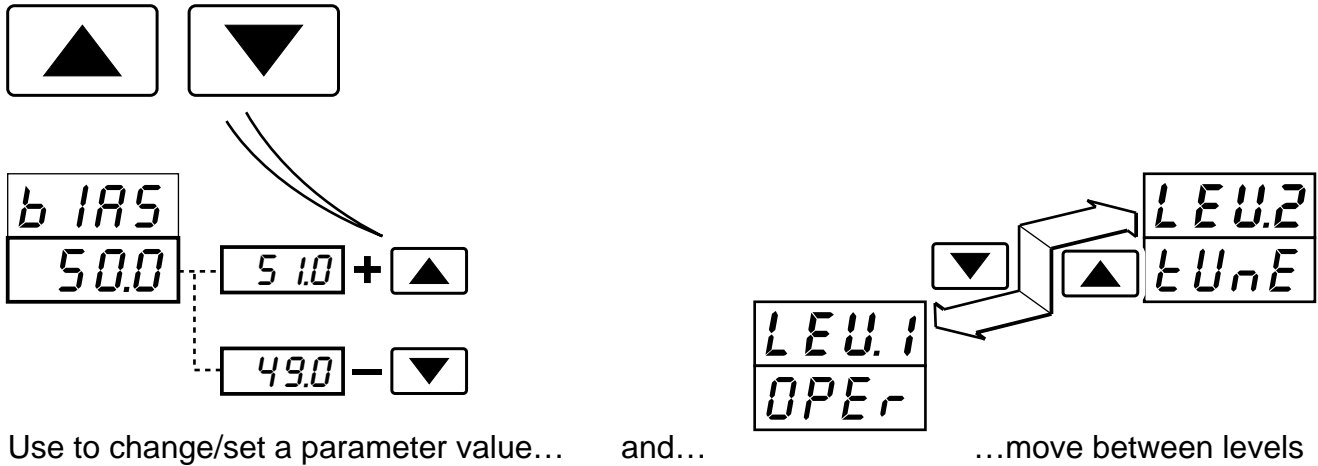

Fig. 1.1 Front Panel Displays, Function Keys and Indicators

1.2 Use of Function Keys – Fig. 1.2

A – Raise and Lower Keys



B – Parameter Advance Key

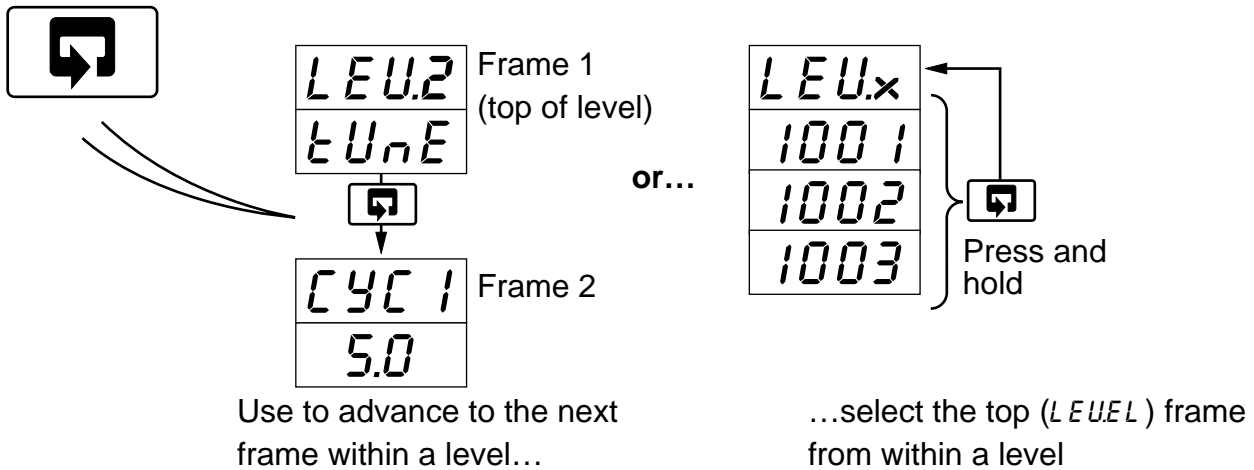

Note. This key also stores any changes made in the previous frame

C – Auto/Manual Key

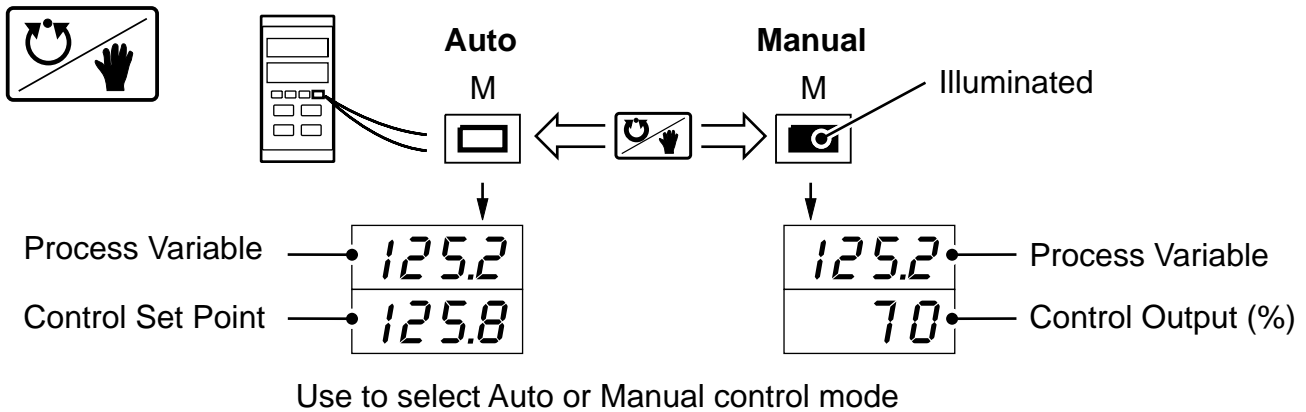
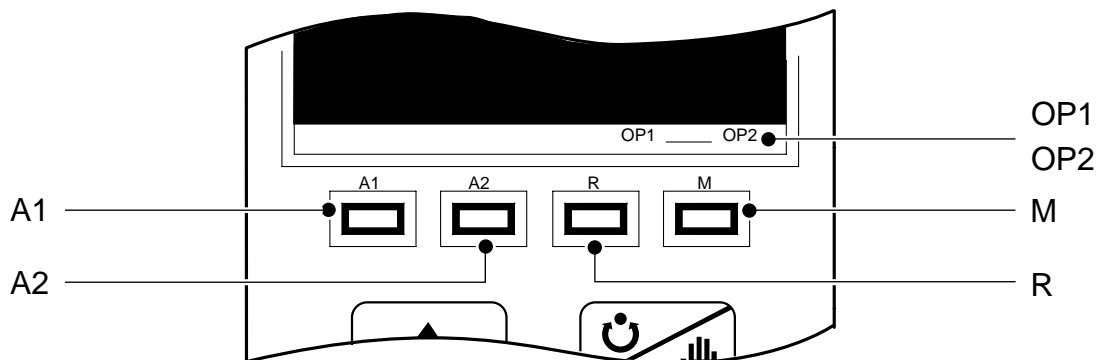

Fig. 1.2 Use of Function Keys

1.3 LED Alarms and Indicators









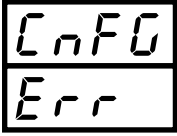

LED Status

- All** • All LED's flashing – controller is in the configuration mode.
- A1** • Flashes when Alarm 1 is active (off when inactive).
- A2** • Flashes when Alarm 2 is active (off when inactive).
- R**
- On when the controller is operating on the remote set point value.
 - Off when the controller is operating using the local set point value or one of the four fixed set points (in multiple set point mode).
 - Flashes when a Ramp/Soak profile is running.
- M**
- On when the controller is operating in Manual control mode.
 - Off when the controller is operating in Auto control mode.
 - Flashes when the controller is performing an auto-tune.
- OPI** • Secret-til-lit LED indicates when the output 1 (heat) value is displayed in the lower display.
- OP2** • Secret-til-lit LED indicates when the output 2 (cool) value is displayed in the lower display.

Fig. 1.3 LED Alarms and Indicators

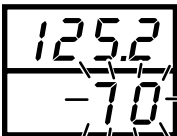
1.4 Error Messages

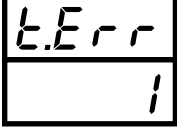
| Display | Error/Action | To Clear Display |
|---|---|---|
|  | Calibration error Turn mains power off and on again (if the error persists contact the Service Organization). | Press the  key |
|  | Configuration error The configuration and/or setup data for the instrument is corrupted. Turn mains power off and on again (if the error persists, check configuration/setup settings). | Press the  key |
|  | A to D Converter Fault The analog to digital converter is not communicating correctly. | Turn power off and on again, if the problem persists contact the service organization |
|  | Process Variable Over/Under Range | Restore valid input |
|  | Remote Set Point Over/Under Range The remote set point value is over or under range. Flashing stops automatically when the remote set point input comes back into range. | Select the local set point (<i>rSP.n</i>) in the Operating Page or the Set Points Level |
|  | Option error Communications to the option board have failed. | Contact the Service Organization |
|  | Auto-tune error The number displayed indicates the type of error present – see Table 2.1 in Section 2.7. | Press any key |



2 OPERATOR MODE

2.1 Introduction

Operator Mode (Level 1) is the normal day-to-day mode of the COMMANDER 100.

Frames displayed in level 1 are determined by the control strategy which is selected during configuration of the instrument – see Section 4.



Note. Only the operating frames relevant to the configured strategy are displayed in Operator Mode.

The five control strategies are:

- **Standard controller** – page 8
- **Heat/Cool controller** – page 9
- **Remote Set Point controller** – page 10
- **Profile controller** – page 12
- **Multiple Fixed Set Points controller** – page 14



2.2 Standard Controller

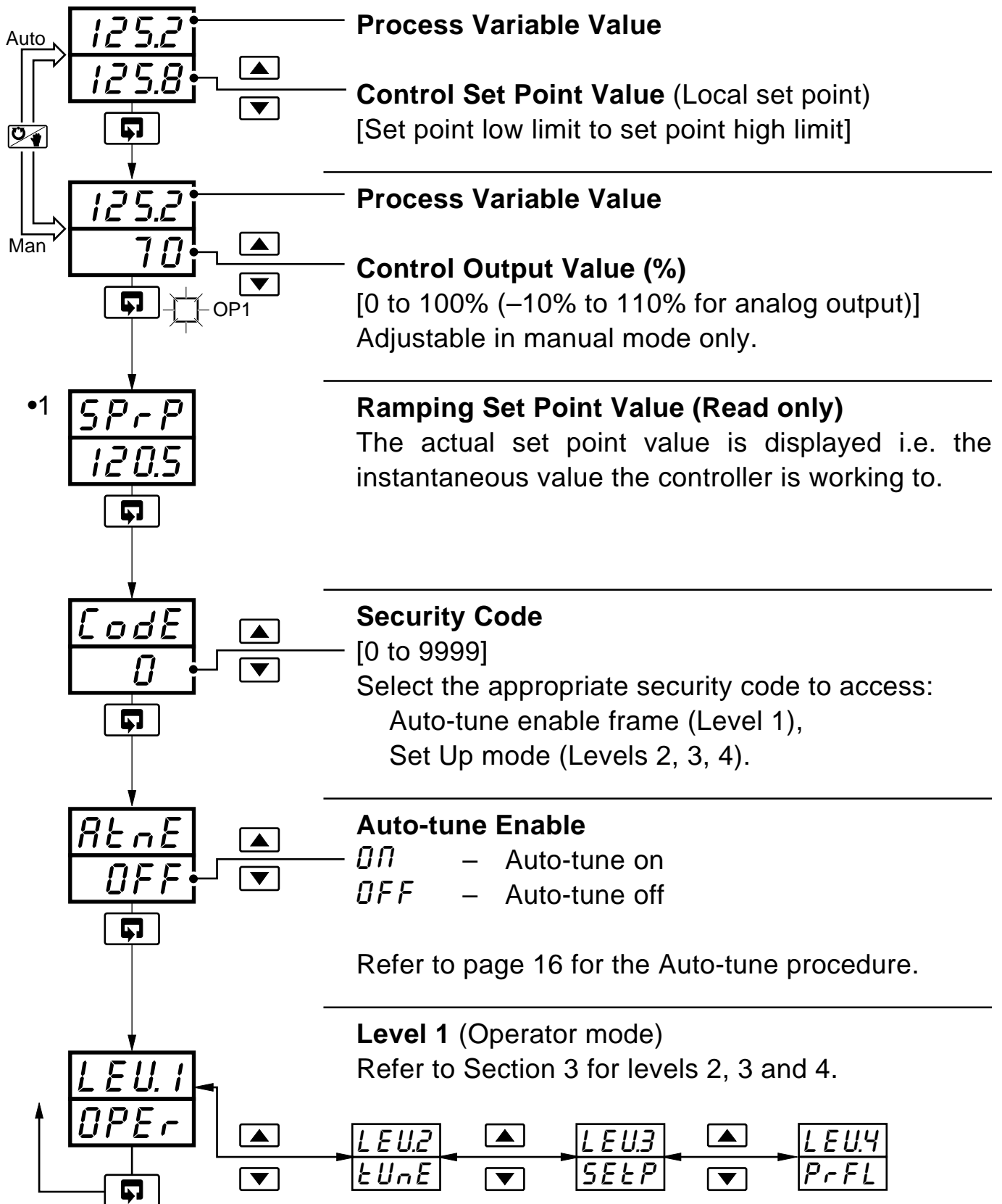

*1 Not displayed if the ramping set point facility is turned off – refer to Section 3.3.



2.3 Heat/Cool Controller

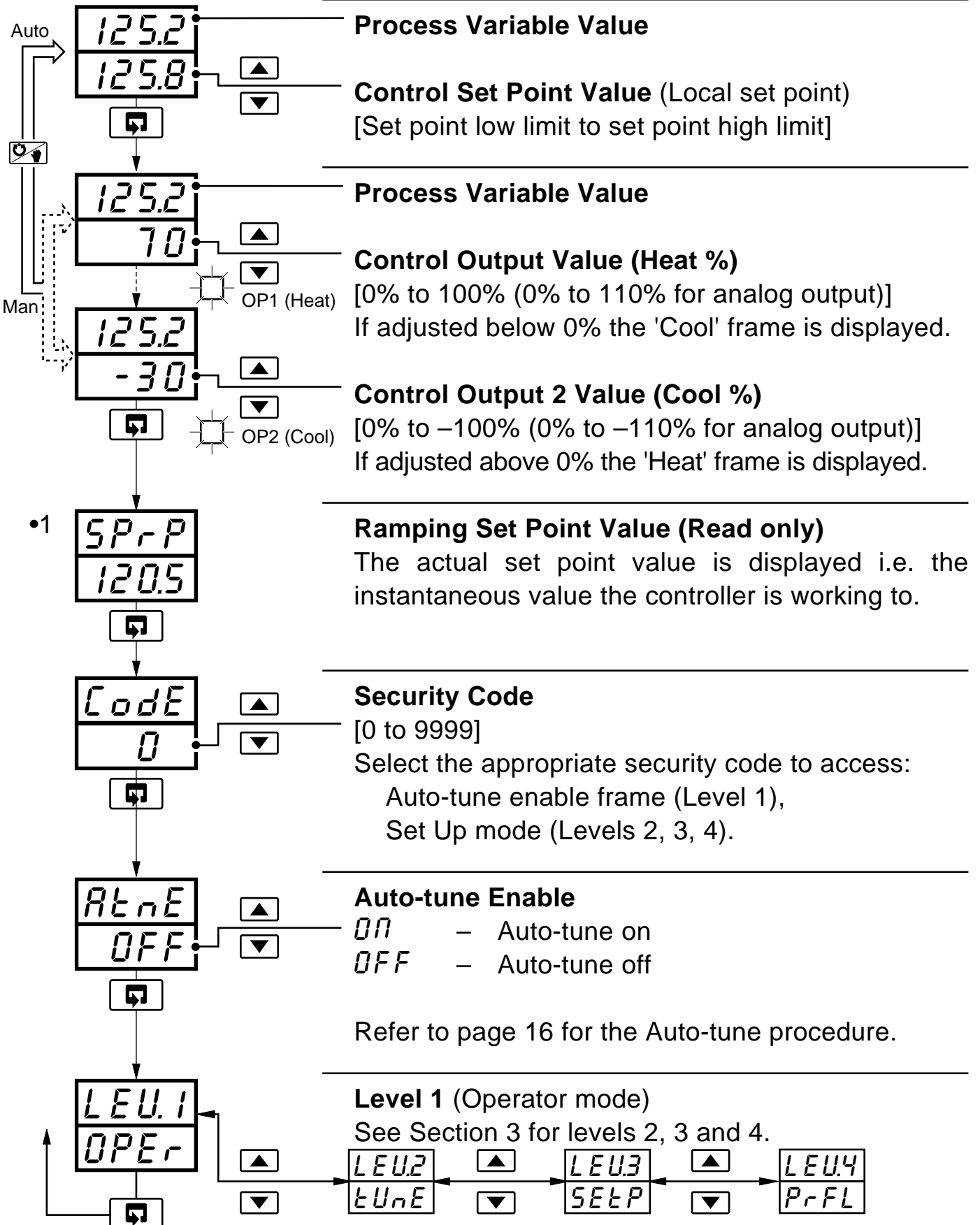

•1 Not displayed if the ramping set point facility is turned off – refer to Section 3.3.



2.4 Remote Set Point Controller

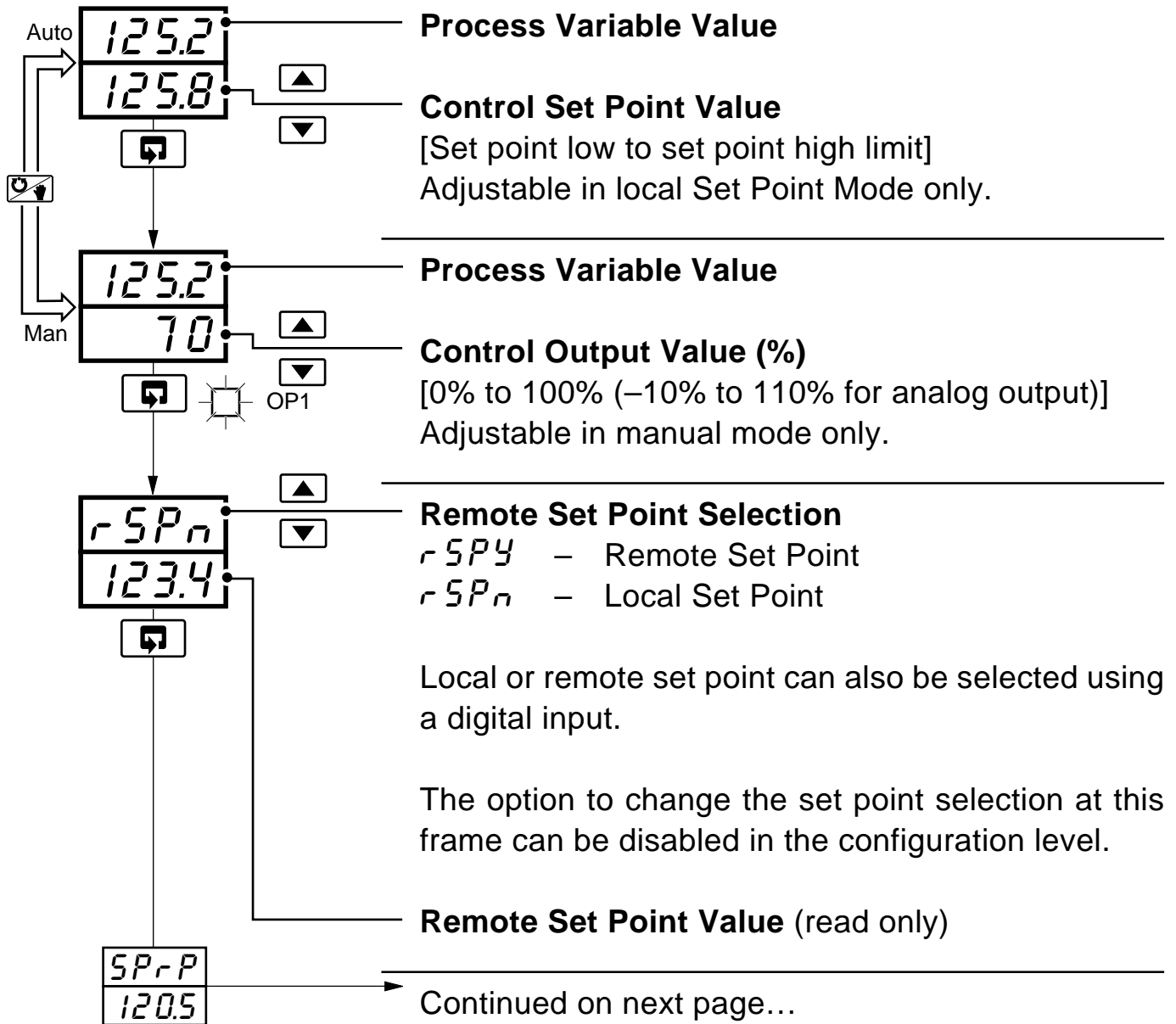

Note.

If the remote set point input fails while selected, the controller automatically selects the local set point value. The upper display changes to *rSPF* and the lower display flashes. When the fault condition is removed the remote set point is re-selected automatically. To clear the error condition while the remote set point input is still outside its allowed range, select the local set point by pressing the key (*rSP.n* is displayed).



...2.4 Remote Set Point Controller

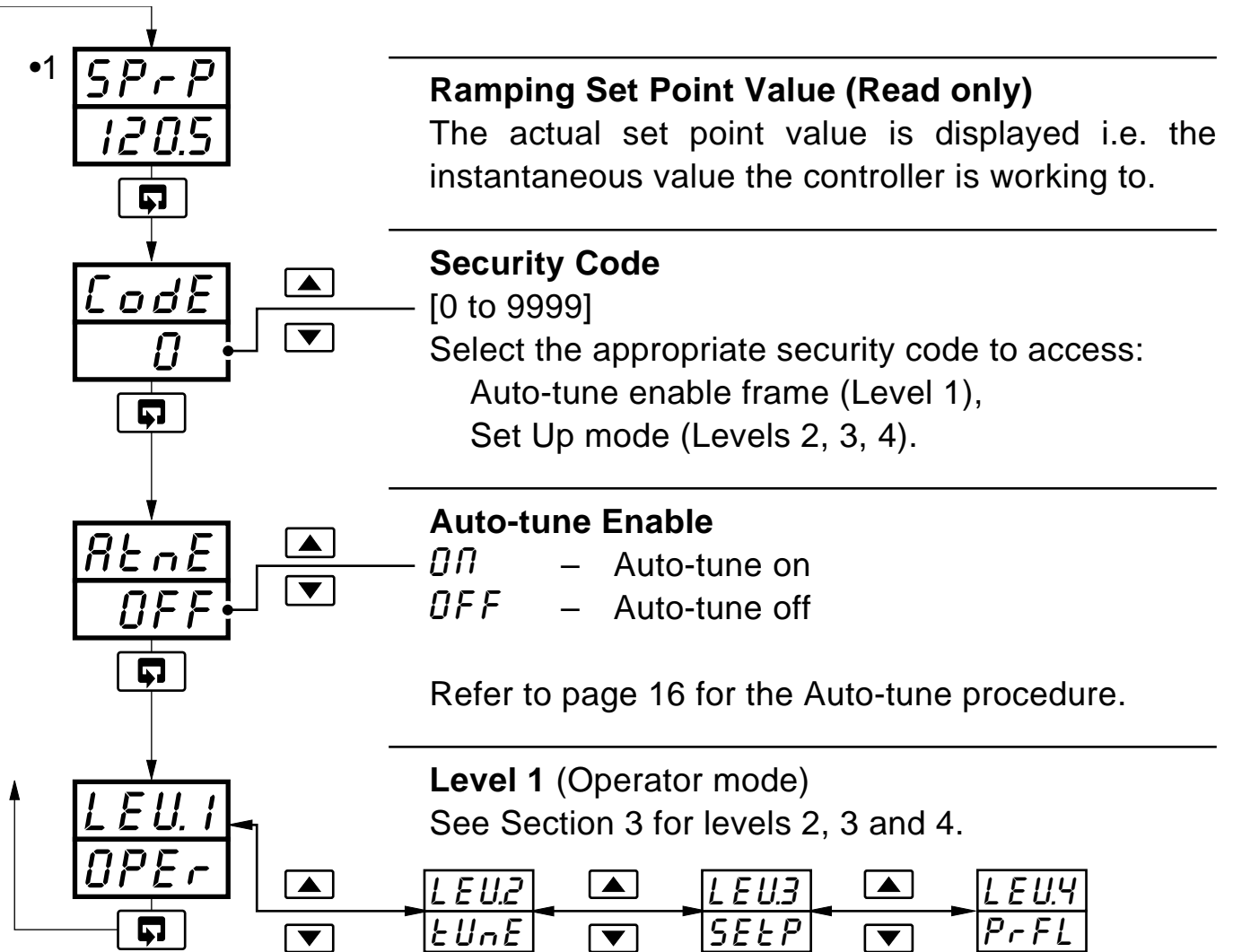

- 1 Not displayed if the ramping set point facility is turned off – refer to Section 3.3.



2.5 Profile Controller

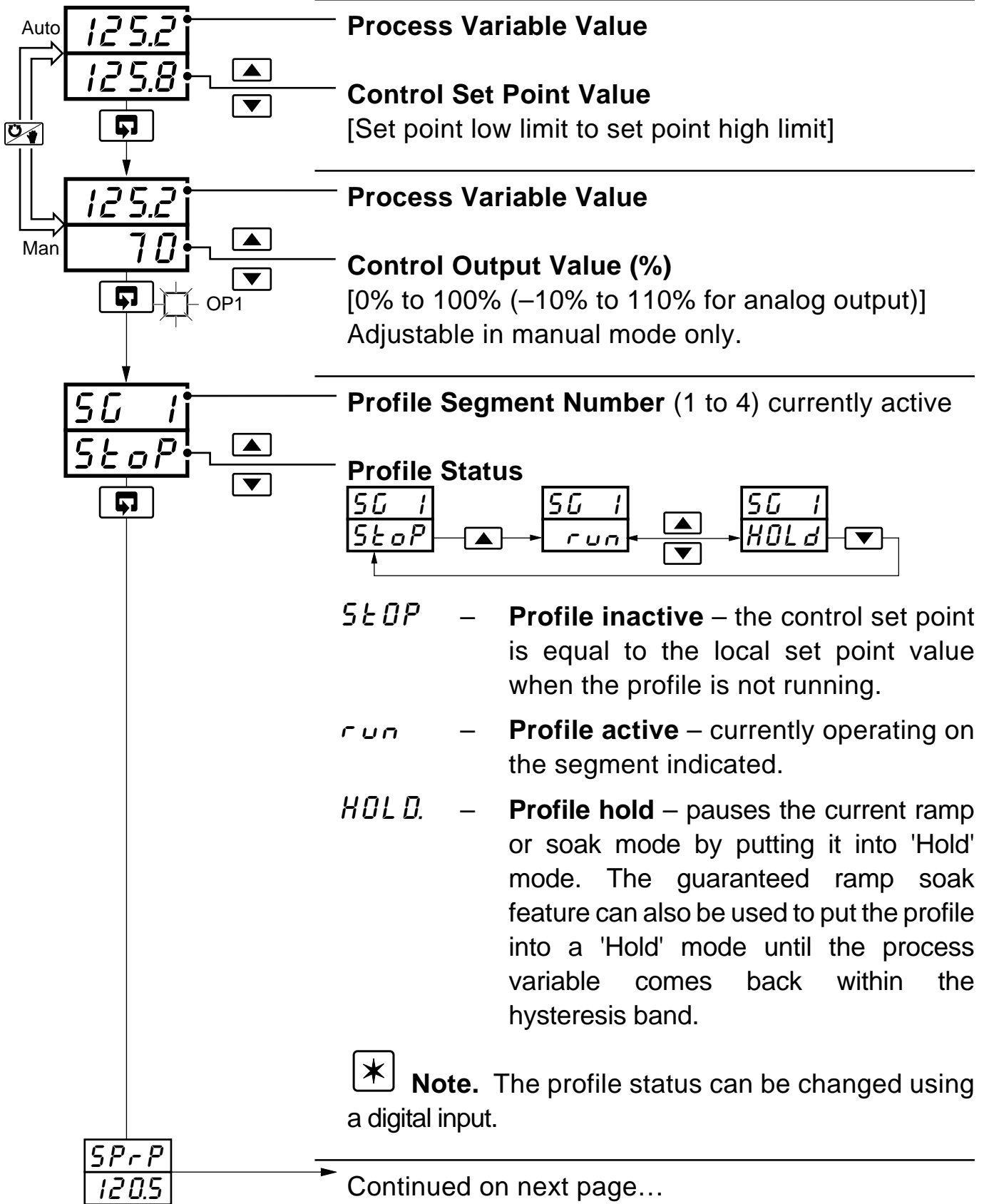



...2.5 Profile Controller

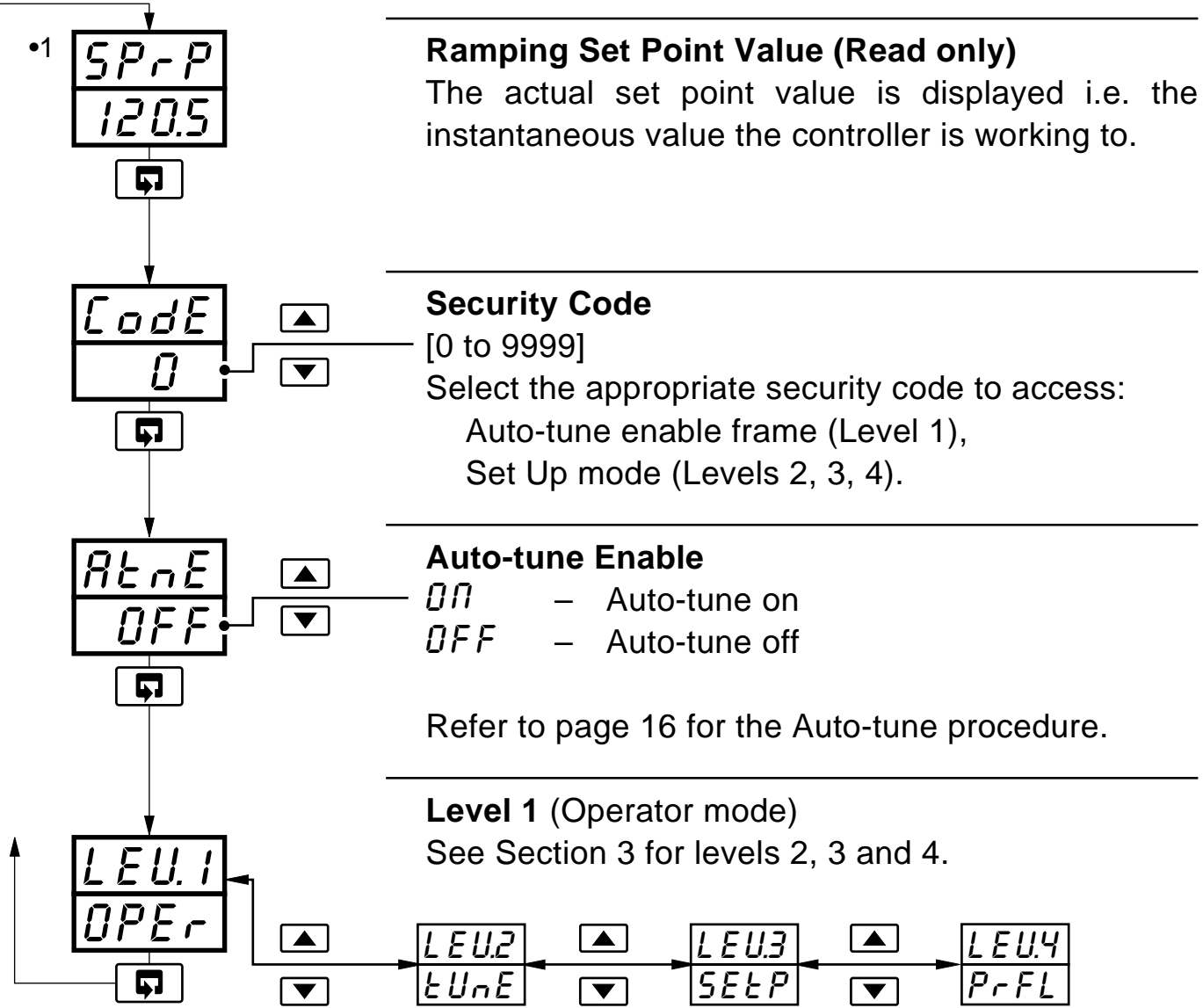

Ramping Set Point Value (Read only)
 The actual set point value is displayed i.e. the instantaneous value the controller is working to.

Security Code
 [0 to 9999]
 Select the appropriate security code to access:
 Auto-tune enable frame (Level 1),
 Set Up mode (Levels 2, 3, 4).

Auto-tune Enable
ON – Auto-tune on
OFF – Auto-tune off

Refer to page 16 for the Auto-tune procedure.

Level 1 (Operator mode)
 See Section 3 for levels 2, 3 and 4.

•1 Not displayed if the ramping set point facility is turned off – refer to Section 3.3.



2.6 Multiple Fixed Set Points Controller

If the Multiple Fixed Set Points Controller type is selected during configuration, four fixed control set points can be set – see Section 4.4.

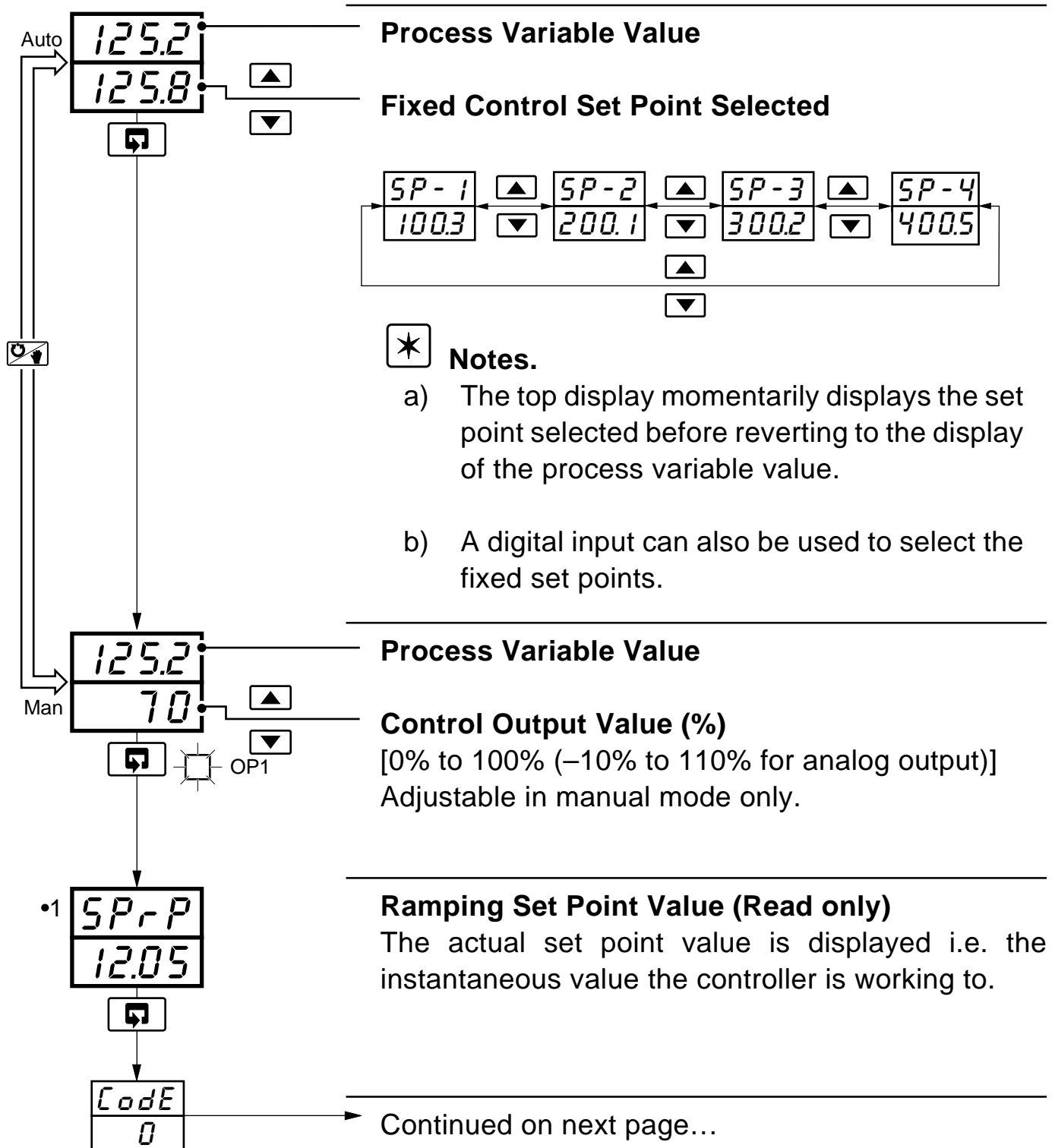

•1 Not displayed if the ramping set point facility is turned off – refer to Section 3.3.

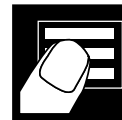

...2.6 Multiple Fixed Set Points Controller

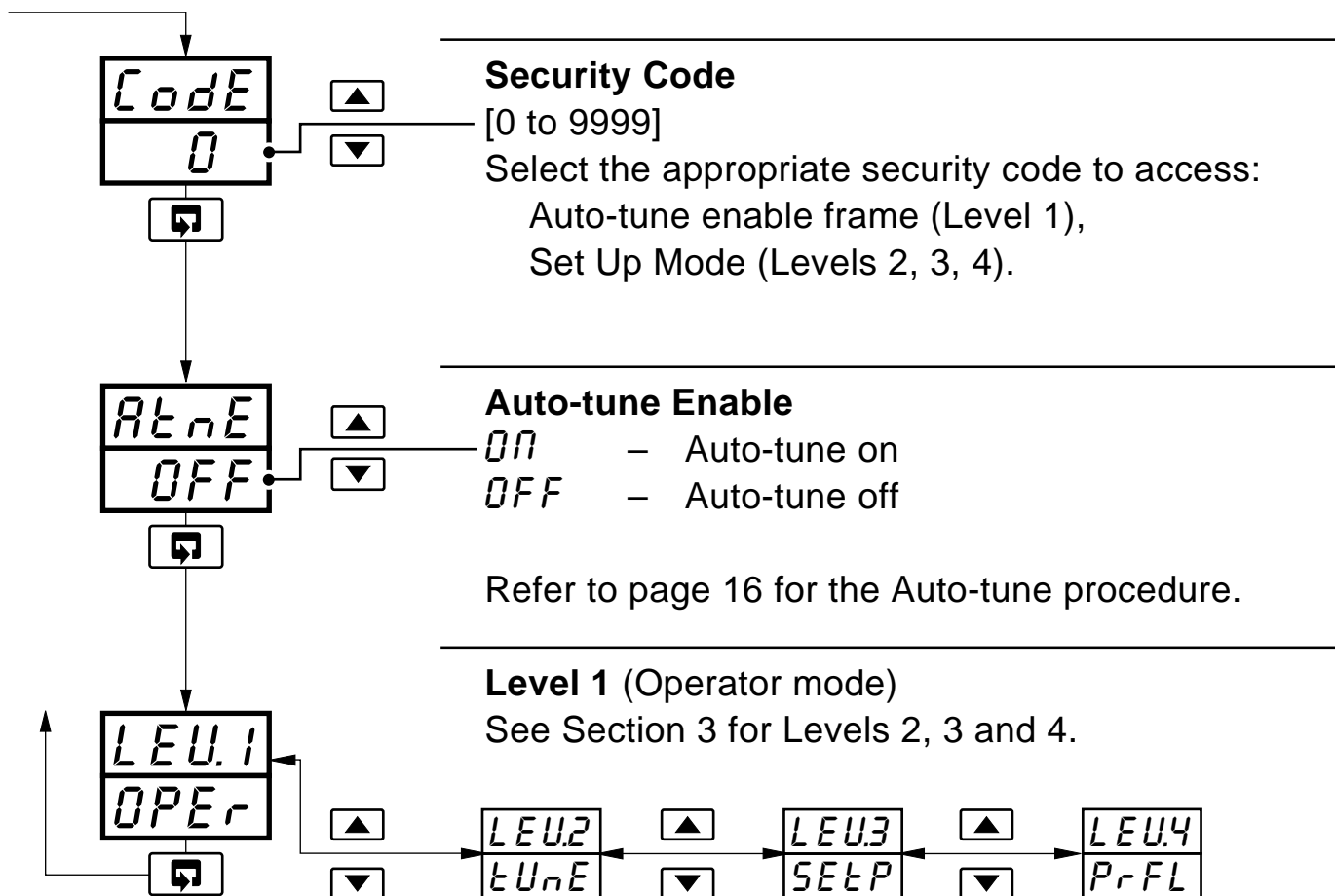



2.7 Auto-tune

i Information.

- Auto-tune optimizes process control by monitoring process performance and automatically updates the control parameters.
- Before starting auto-tune, the process variable must be stable ($\pm 2\%$ of engineering range).

1 – 'At start up' auto-tune (from manual mode)

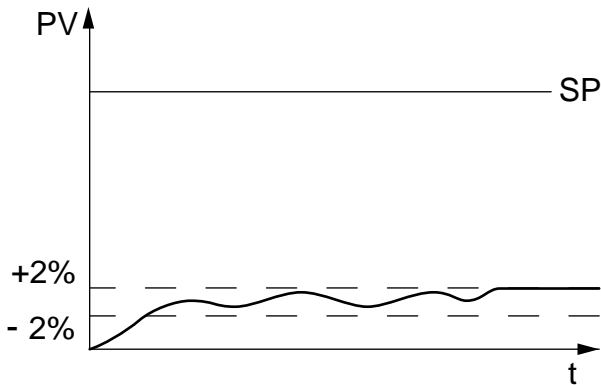

1a – Stable process before auto-tune

2 – 'At set point' auto-tune (from manual or automatic mode)

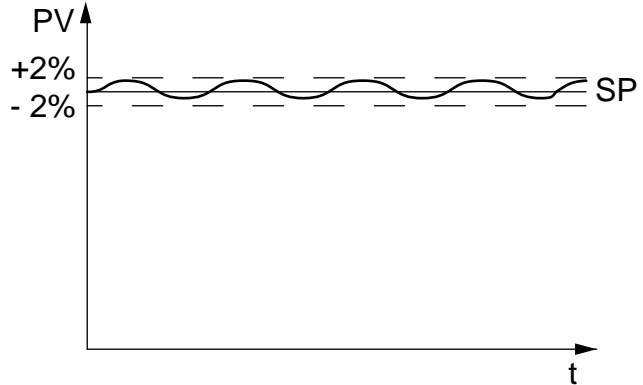

2a – Stable process before auto-tune

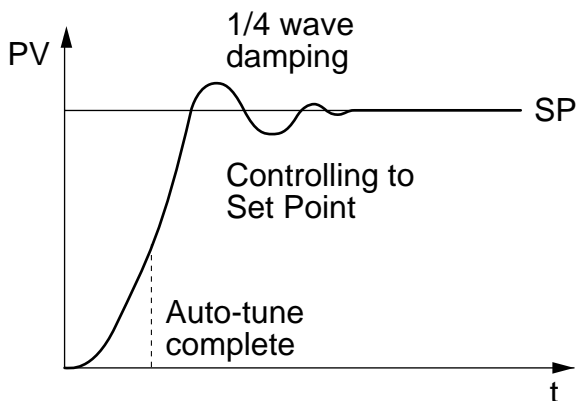

1b – Process response during auto-tune

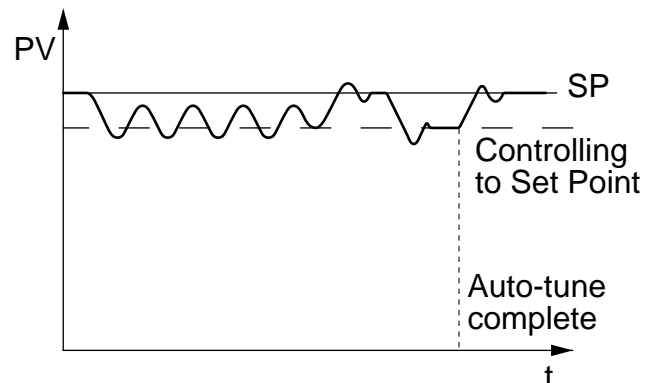

2b – Process response during auto-tune

***** **Note.** The time taken to complete autotune depends upon the system response time.

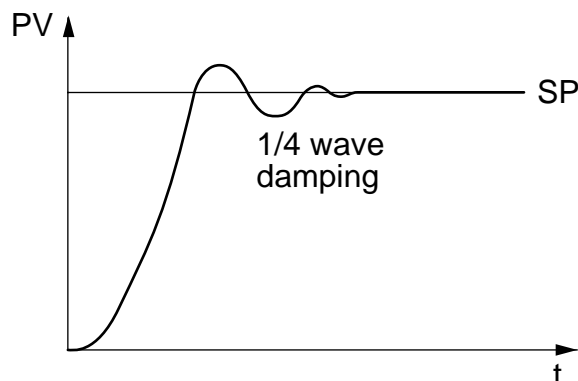

Process response after auto-tune

Fig 2.1 Typical Auto-tune Cycles



...2.7 Auto-tune

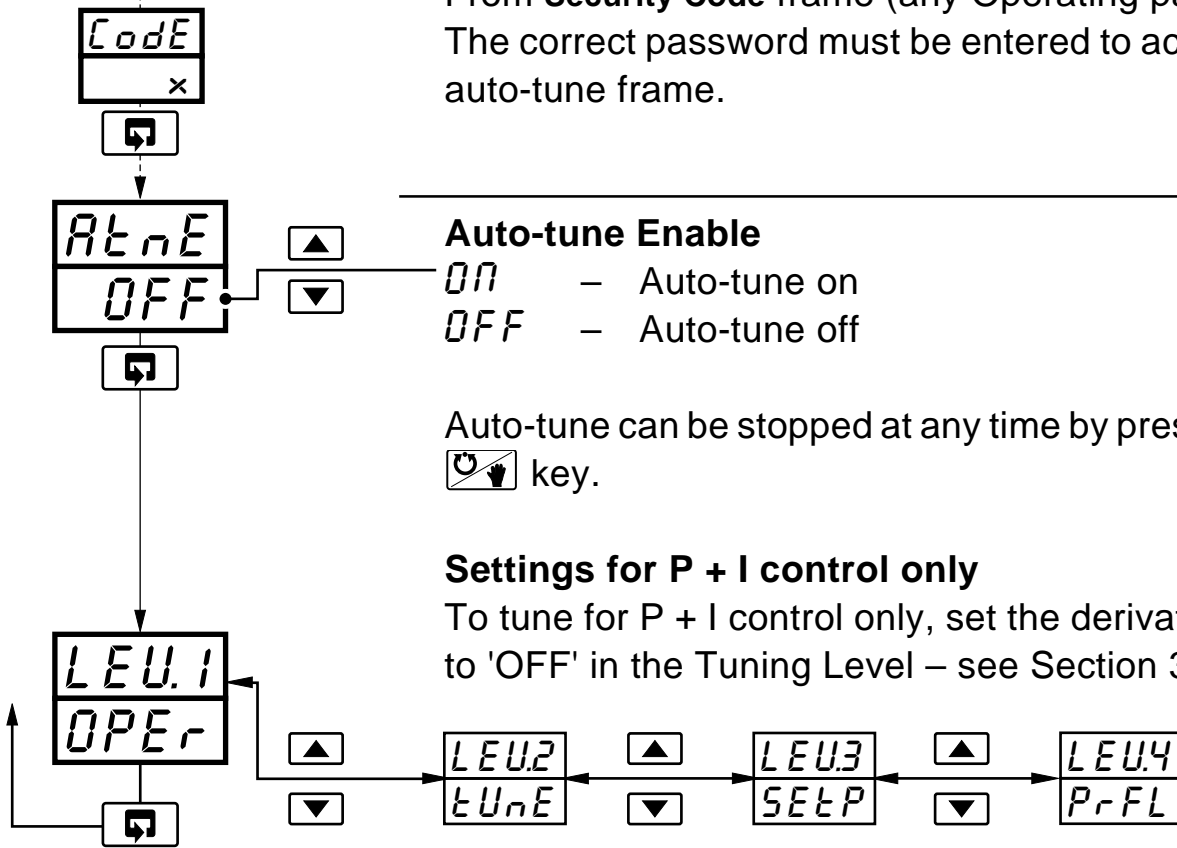

From **Security Code** frame (any Operating page)
The correct password must be entered to access the auto-tune frame.

Auto-tune Enable
ON – Auto-tune on
OFF – Auto-tune off

Auto-tune can be stopped at any time by pressing the  key.

Settings for P + I control only
To tune for P + I control only, set the derivative term to 'OFF' in the Tuning Level – see Section 3.2.

*** Notes.**

- On completion the controller enters auto control mode and begins to control the process using the new PID values. For fine-tuning – see Section 3.
- For heat/cool control the cool proportional band is set to the same value as the heat proportional band (this value may need modification).
- If an error occurs during auto-tune, the controller reverts to manual mode with the control output set to the configured output value. An error message is displayed – see Table 2.1.

| Error | Description | Error | Description |
|-------|---|-------|---|
| 1 | PV failed during auto-tune | 7 | A resultant P, I or D value was calculated out of range |
| 2 | Auto-tune has timed out during an auto-tune step | 8 | PV limit exceeded (At start up auto-tune) |
| 3 | Process too noisy to auto-tune | 9 | Controller put into configuration mode |
| 4 | Process too fast to auto-tune | 10 | Auto-tune terminated by user |
| 5 | Process too slow to auto-tune | 11 | PV is changing in the wrong direction during step test |
| 6 | PV deviated from set point by >25% eng. span during frequency response test | | |

Table 2.1 Auto-tune Error Codes



3 SET UP MODE

3.1 Introduction

To access the Set Up Mode (Levels 2, 3 and 4) the correct password must be entered in the security code frame (the default password code is 0). Refer to the fold-out sheet at the back of this manual for the contents of these levels.

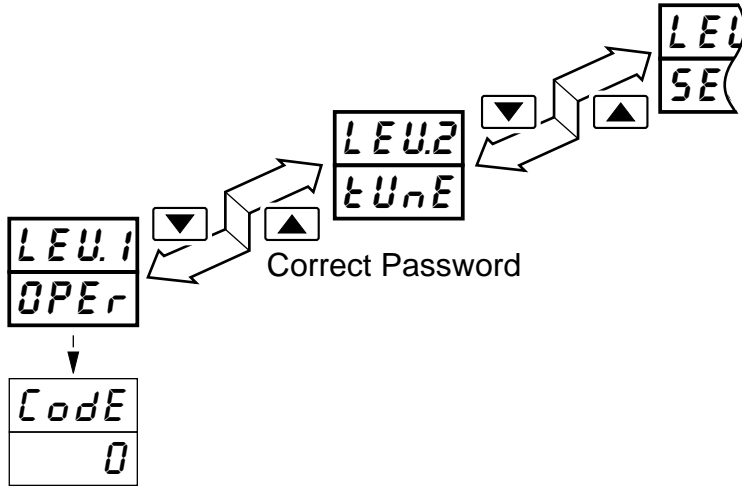

Refer to the fold-out sheet for the contents of each level

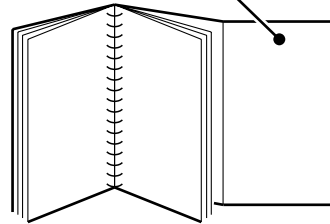

3.2 Tuning (Level 2) – Fig. 3.2

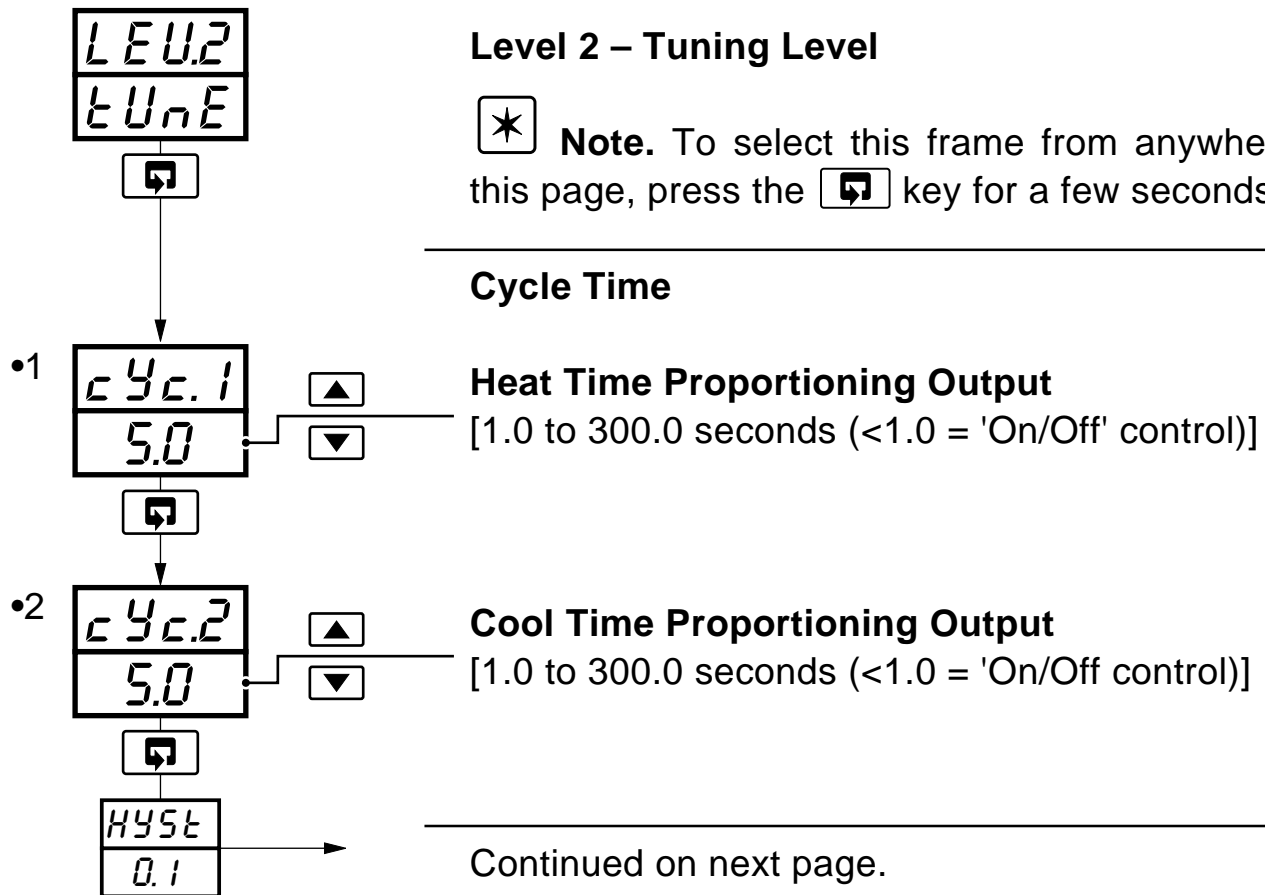

Continued on next page.

- 1 Only displayed if output 1 is assigned to a relay or logic output.
- 2 Only displayed if heat/cool hardware configuration is selected.



...3.2 Tuning (Level 2) – Fig. 3.2

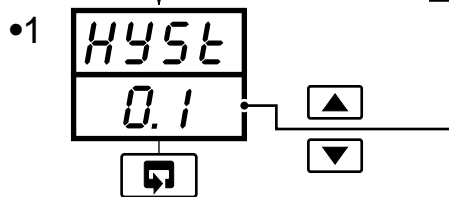

On/Off Hysteresis Value
 (used for both heat and cool outputs)
 [In engineering units]

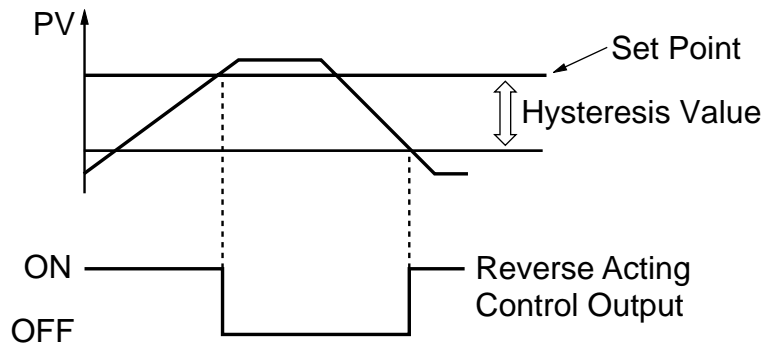

Proportional Band
 Enter the proportional band value for the heat and cool outputs.

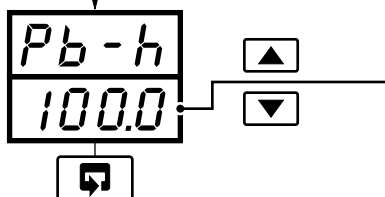

Heat Output (Output 1)
 [0.1% to 999.9%]

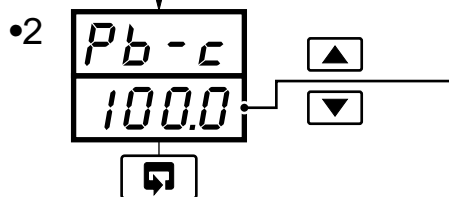

Cool Output (Output 2)
 [0.1% to 999.9%]

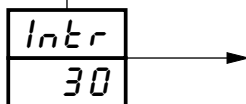

Continued on next page.

- 1 Only displayed if On/Off control is selected for either output.
- 2 Only displayed if heat/cool hardware configuration is selected.



...3.2 Tuning (Level 2)

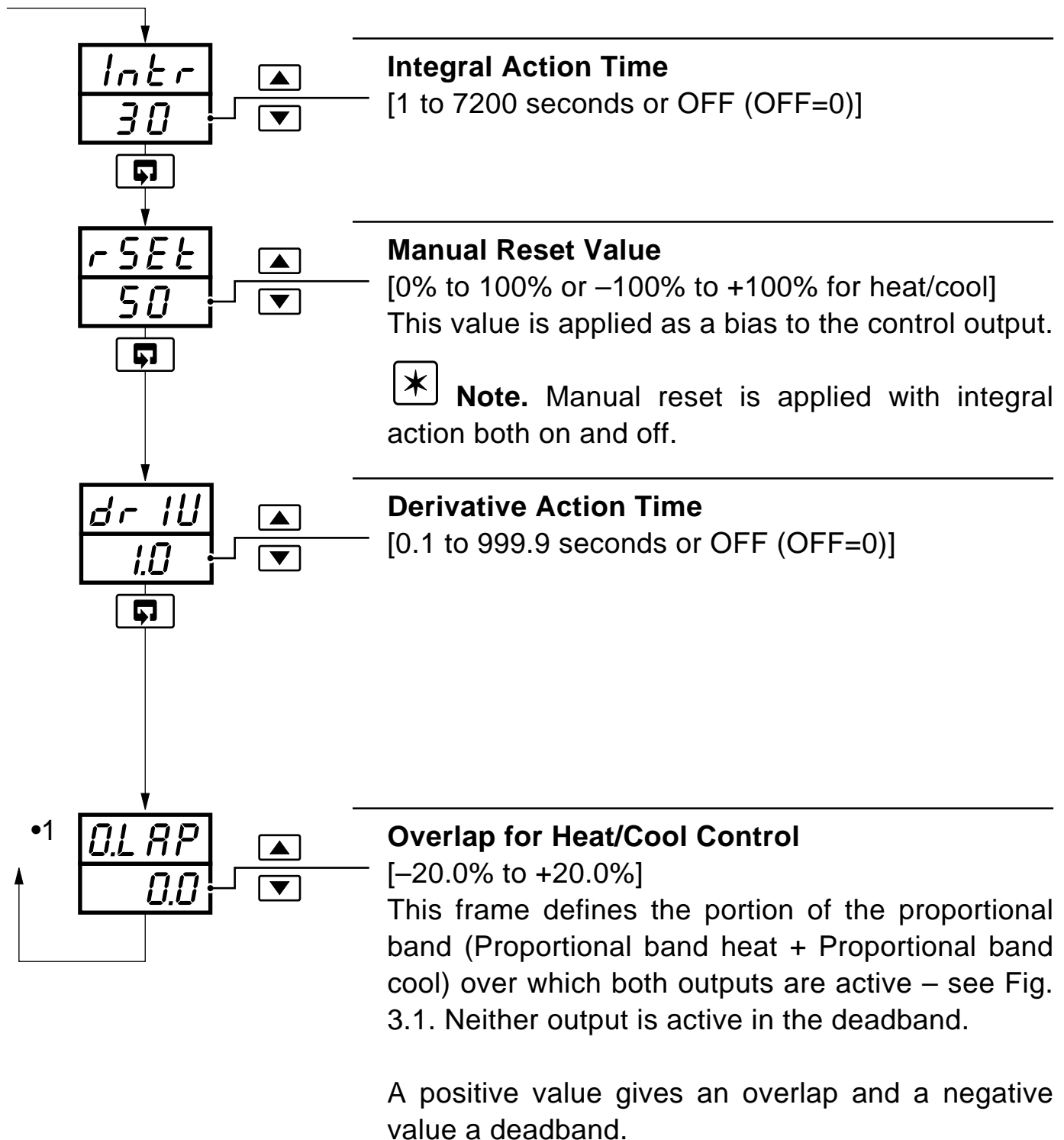

•1 Only displayed if a heat/cool hardware configuration is selected.

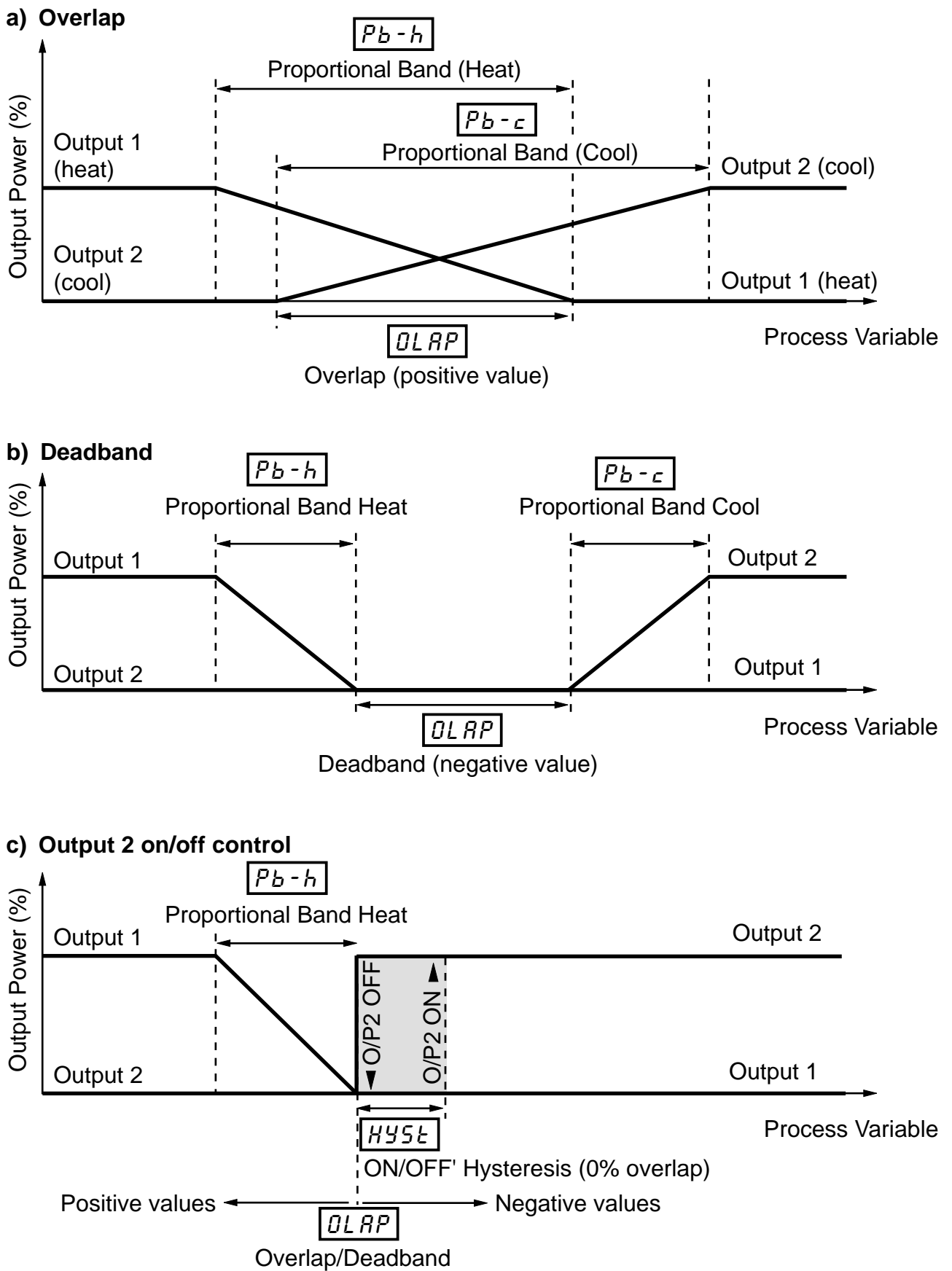
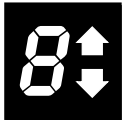
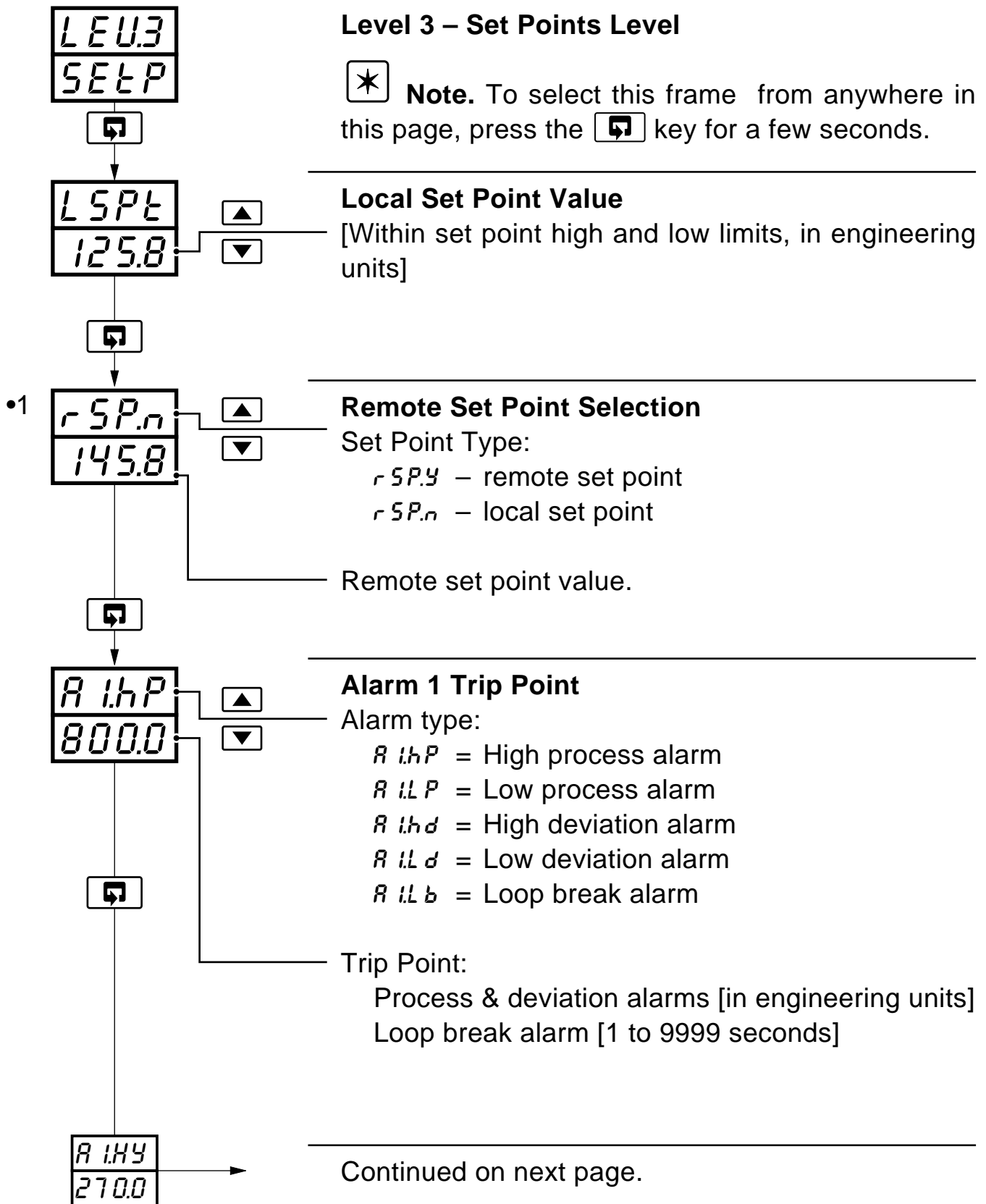

Fig. 3.1 Proportional Band & Deadband/Overlap – Heat/Cool Control Only



3.3 Set Points (Level 3)



•1 Only displayed if the remote set point option is selected.



...3.3 Set Points (Level 3)

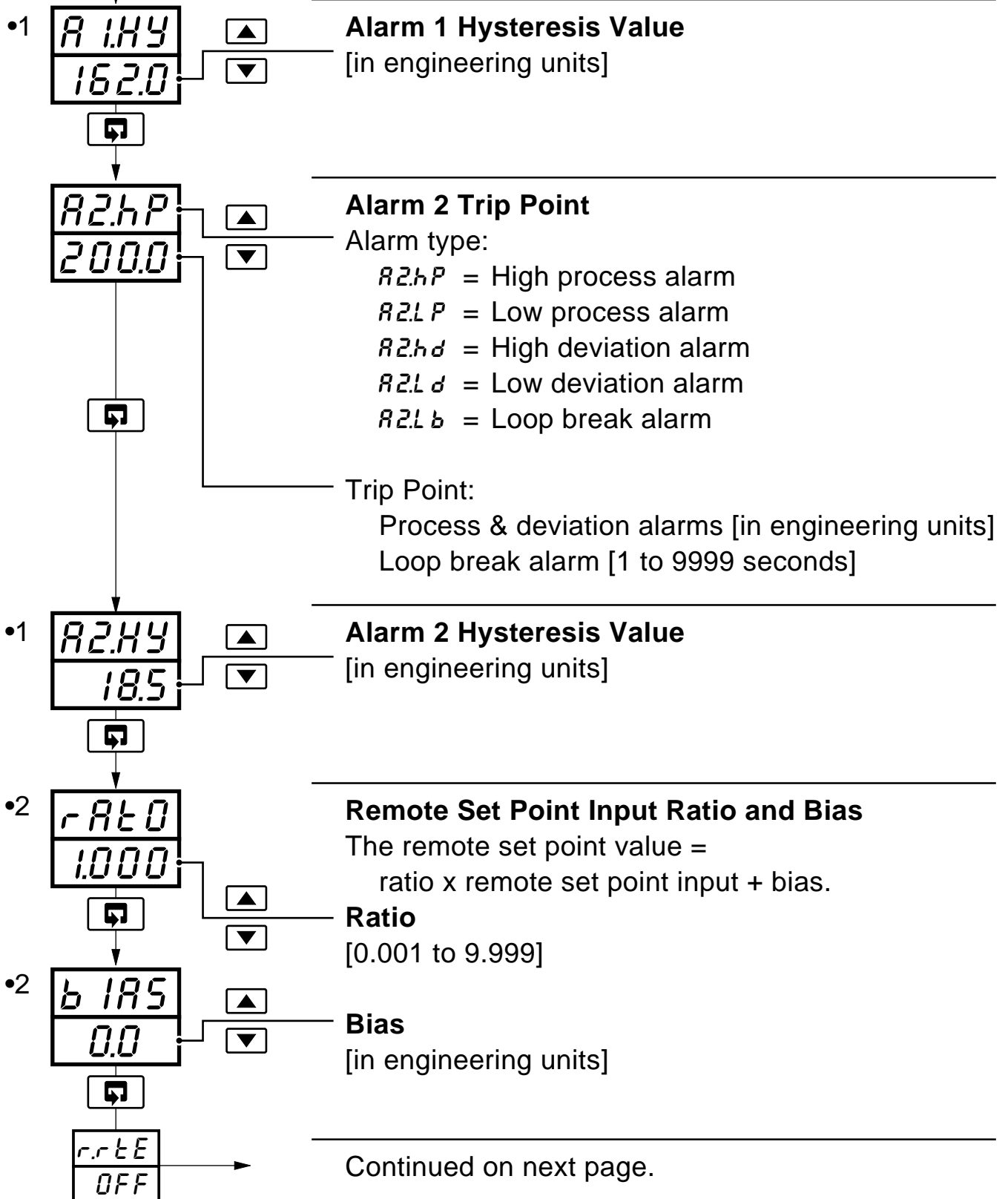

- 1 Only displayed if custom alarm hysteresis is selected – see section 4.3.2, not displayed if Loop Break Alarm type selected.
- 2 Only displayed if the remote set point option is selected.

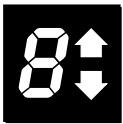

...3.3 Set Points Level

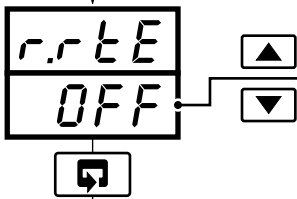

Ramp Rate (for ramping set point facility)
 [1 to 9999 engineering units per hour, or OFF]

The ramping set point facility can be used to prevent a large disturbance to the control output when the set point value is changed. This only applies to the local and multiple fixed set points.

*** Note.** For remote set points the ramp rate is applicable when switching from remote to local, not local to remote

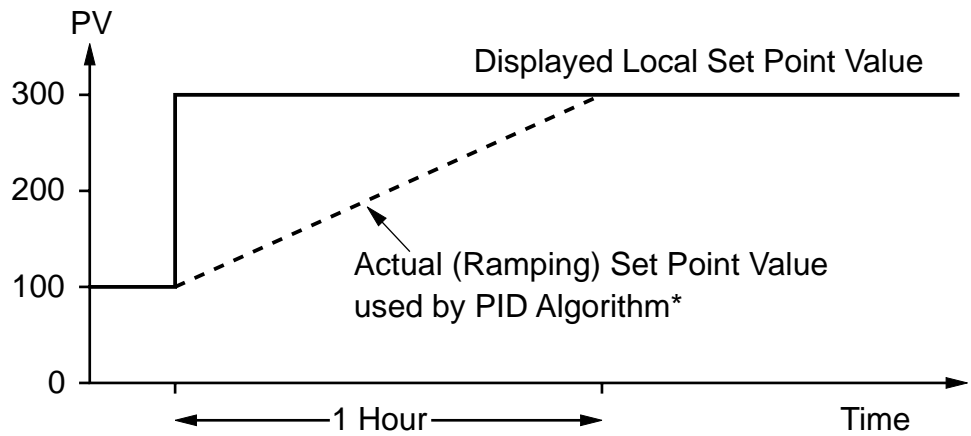

* e.g. Ramp Rate = 200 Increments/Hour

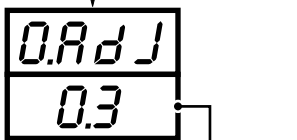

Offset Adjustment

An offset can be applied to the process variable input to enable spot calibration or the removal of system errors.

[±10% of engineering range in engineering units]



3.4 Profile (Level 4)

A four segment ramp/soak profile facility is provided. This level can only be accessed if the profile option is selected in the configuration level. The four segments are fixed as ramps or soaks as follows:

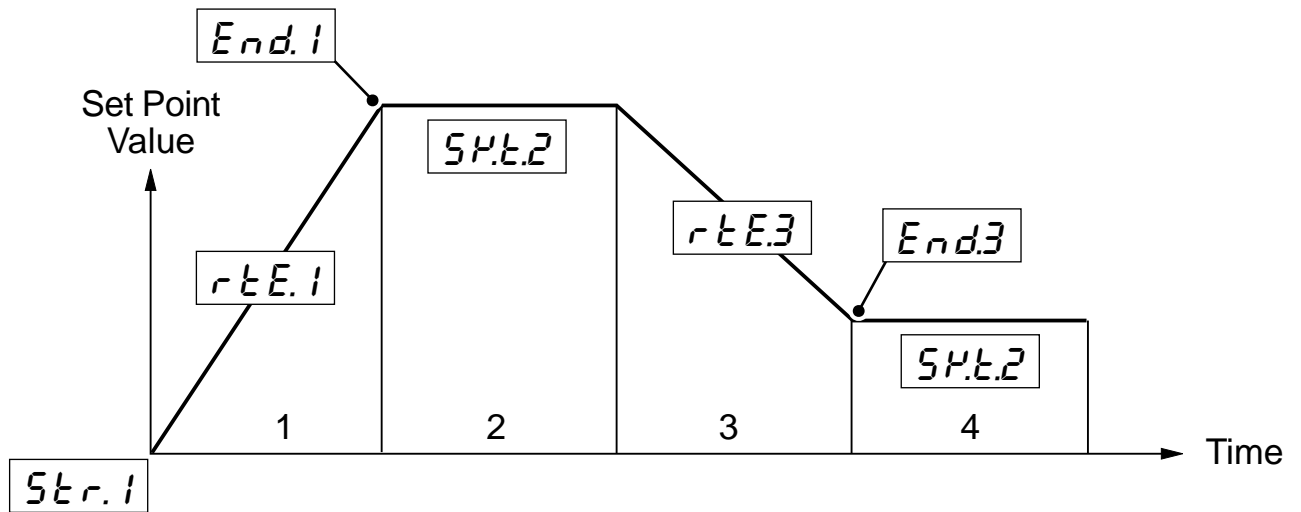

LEU.4
PrFL



•1

Str.1
1000



End.1
2000



rtE.1
100

Level 4 – Profile Level



Note. To select to this frame from anywhere in this page, press the key for a few seconds.

Start value for 1st Segment (ramp).

[Within display range (in engineering units)]

Enter the start value required.

End Value for 1st Segment (ramp).

[Within display range (in engineering units)]

Enter the end value required.

Continued on next page.

- 1 With the self-seeking set point facility enabled, the first ramp starts at the current process variable value instead of the start value for the 1st segment.

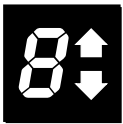

...3.4 Profile (Level 4)

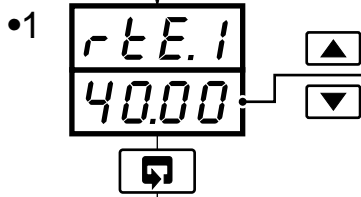

Ramp Rate for 1st Segment.

[Engineering units*]

Enter the ramp rate required.

* The time option Eng Units/hr or Eng Units/min is set in the configuration level – see section 4.3.2.

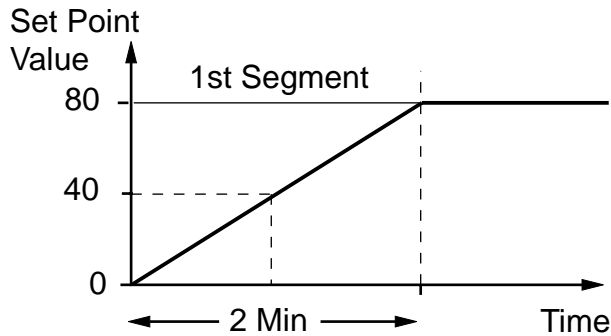

Example. Required Ramp Rate 40°C/min
Ramp Rate set to 40, Time Option set to 'Min' – see section 4.3.2

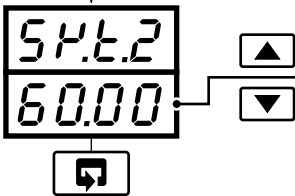

Soak Time for 2nd Segment.

[0 to 999.9 minutes or hours]*

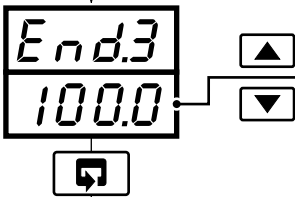

End Value for 3rd Segment (ramp).

[Within display range (in engineering units)]

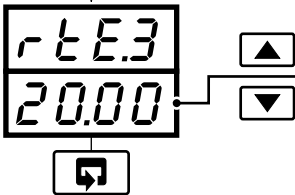

Ramp Rate for 3rd Segment.

[Engineering units/hour or /minute]*

* Depending on the time option selected in the configuration level.

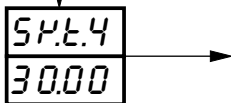

Continued on next page.

•1 The engineering value is shown with an extra decimal place (up to a maximum of 3) for greater accuracy in setting the ramp rate.



...3.4 Profile (Level 4)

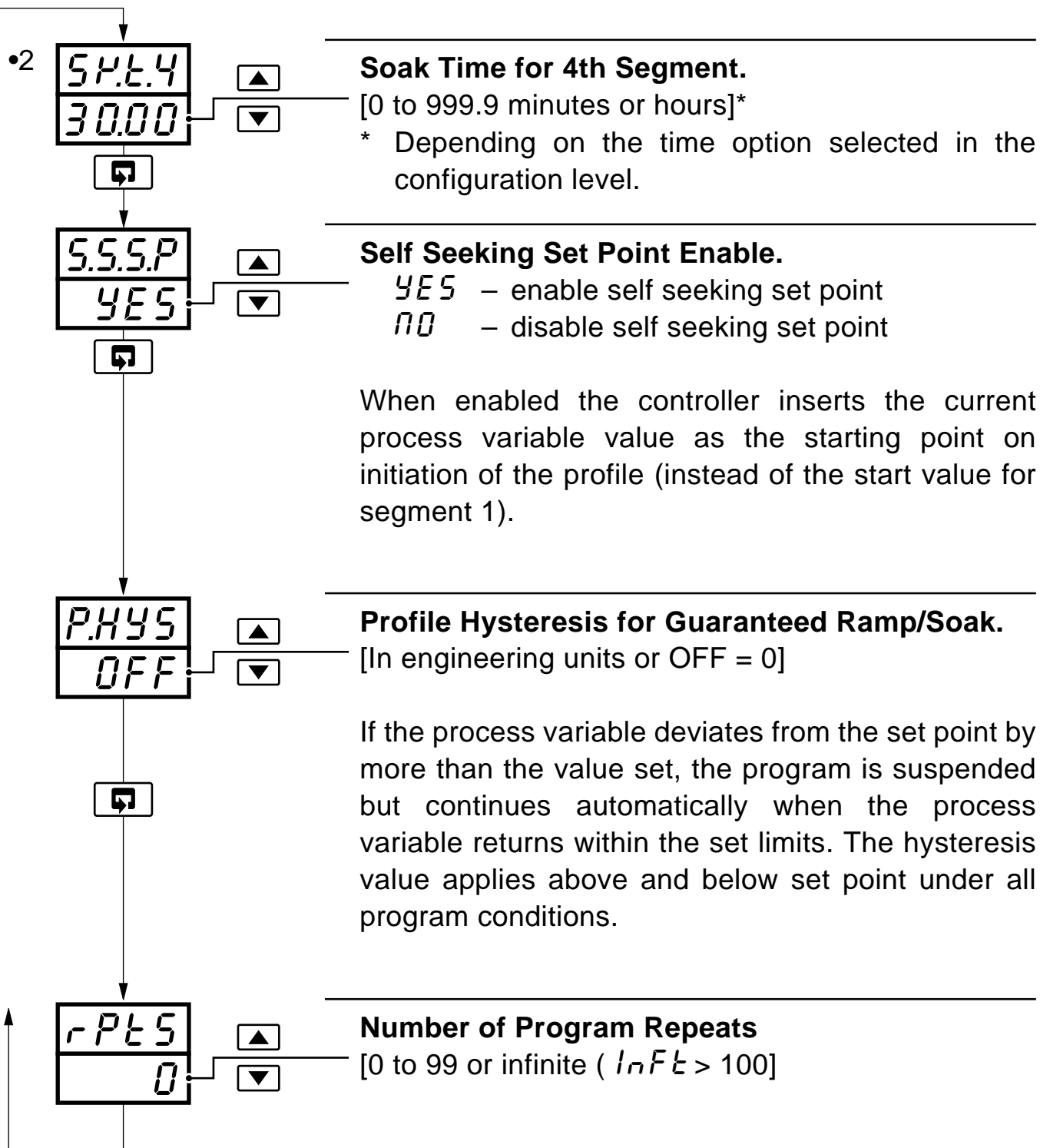

- 2 The engineering value is shown with an extra decimal place (up to a maximum of 3) for greater accuracy in setting the ramp rate.



4 CONFIGURATION MODE

4.1 Introduction

The Configuration Mode comprises two levels (5 and 6) as shown in Fig. 4.2.

Level 5 is divided into four frames. For most simple applications it is only necessary to set up the parameters in the first frame.

*** Note.**

When in the configuration level:

- All the l.e.d. indicators flash.
- All relays and logic outputs are turned off.
- The analog output reverts to 0% (4mA) output level.

4.2 Accessing the Configuration Mode – Fig. 4.1

To access the Configuration Mode set the security switch to the 'Configure' position (levels 1 to 4 cannot be accessed from this setting). When the configuration parameters are programmed, reset the security switch to the 'Normal' position and the Operating page is displayed automatically .

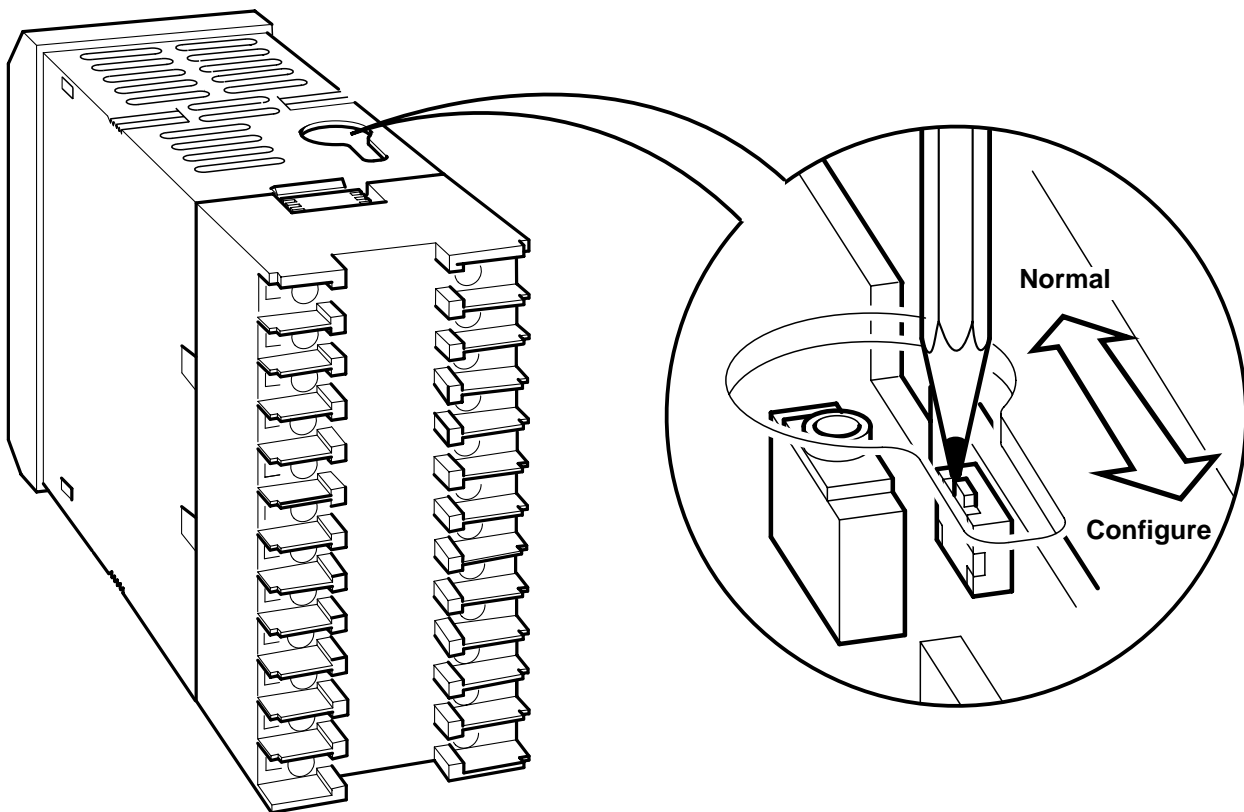

Fig. 4.1 Accessing the Configuration Mode (Config/Normal Switch)

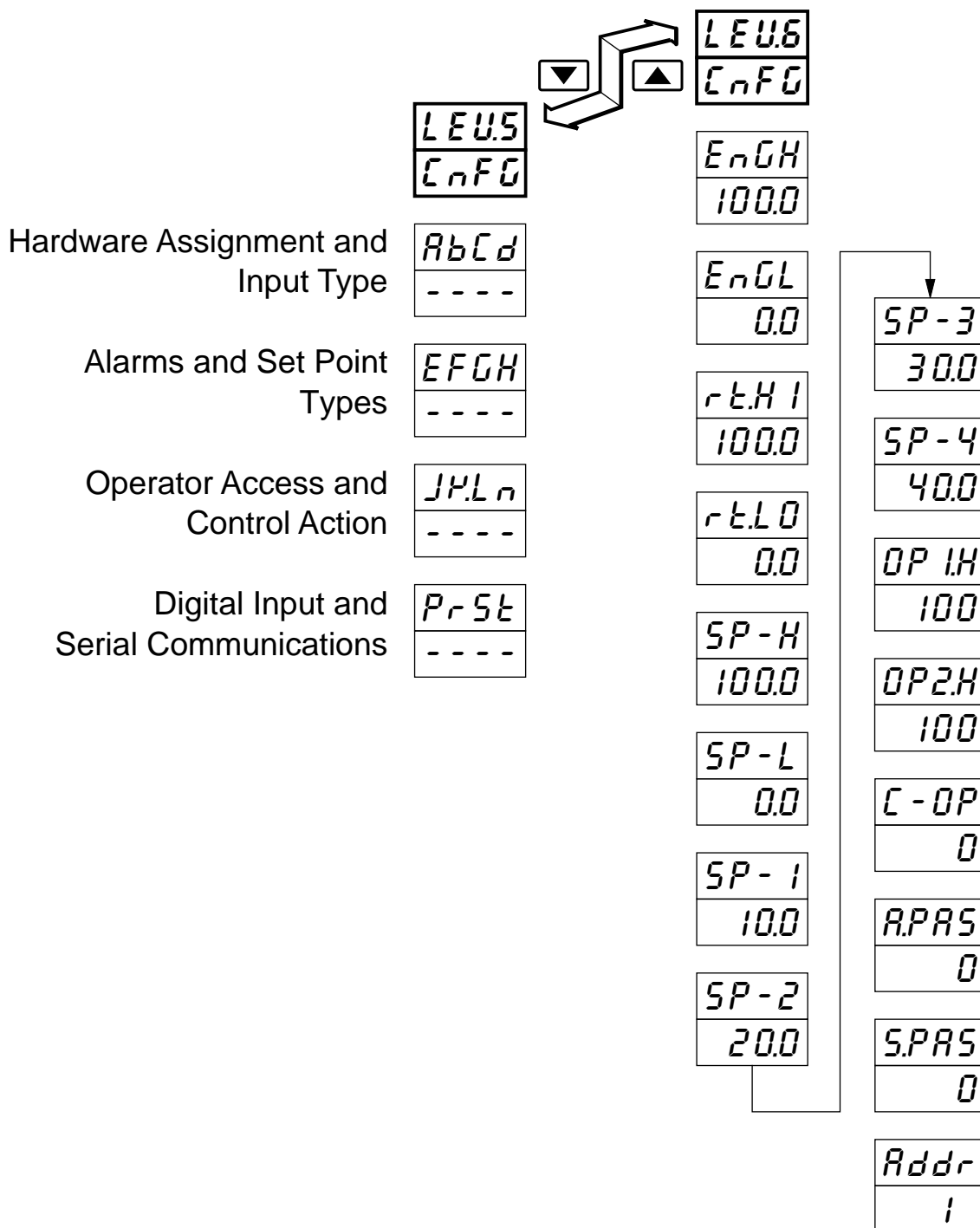
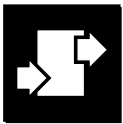
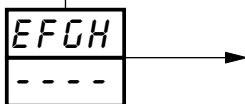
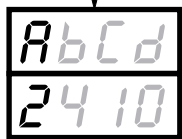
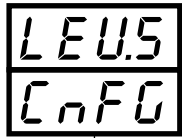

Fig. 4.2 Configuration Frames (Levels 5 and 6)



4.3 Basic Hardware and Configuration (Level 5)

4.3.1 Hardware Assignment and Input Type – Fig. 4.3



Level 5 –Configuration

★ **Note.** To select this frame from anywhere in this page, press the  key for a few seconds.

'ABCD' Settings



The parameter to be changed is indicated by the letter which is flashing. Parameter options are shown in Fig. 4.3.

- A* = Hardware configuration
- b* = Input type and range
- C* = Temperature units
- d* = Process variable display decimal places

★ **Note 1.** The temperature ranges default to their maximum values when the input type is changed.

★ **Note 2.** For custom settings contact the local distributor.

Continued on page 32.



A – Hardware Configuration

| Freq. | | Relay 1 | Relay 2* | Relay 3* | Logic O/P | An. O/P | Control Type |
|-------|------|----------|----------|----------|-----------|----------|-------------------------------------|
| 50Hz | 60Hz | | | | | | |
| 1 | A | Output 1 | Alarm 1 | Alarm 2 | Output 1 | PV | Time Prop. or On/Off |
| 2 | b | Alarm 1 | Alarm 2 | None | None | Output 1 | Analog Prop. |
| 3 | c | Output 1 | Output 2 | Alarm 1 | Output 1 | PV | Heat – Time Prop. Cool – Time Prop. |
| 4 | d | Output 2 | Alarm 1 | Alarm 2 | Output 2 | Output 1 | Heat – Analog Cool – TP or On/Off |
| 5 | E | Alarm 1 | Alarm 2 | None | Output 1 | PV | Alarm Unit or Logic O/P Time Prop. |
| U | | Custom | Custom | Custom | Custom | Custom | Custom |

* Only available if option board is fitted

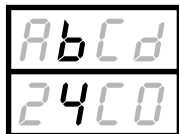

B – Input Type and Range Configuration

| Display | | Display | |
|---------|------------|---------|-------------------------------------|
| b | THC Type B | 1 | 0 to 20 mA |
| E | THC Type E | 2 | 4 to 20 mA |
| J | THC Type J | 3 | 0 to 5 V |
| K | THC Type K | 4 | 1 to 5 V |
| N | THC Type N | 6 | 0 to 50 mV |
| R | THC Type R | 7 | 4 to 20 mA (square root lineariser) |
| S | THC Type S | U | Custom Configuration |
| T | THC Type T | | |
| P | PT100 RTD | | |



C – Temperature Units

| Display | Temperature Units |
|---------|----------------------|
| C | Degrees C* |
| F | Degrees F* |
| 0 | No temperature units |



D – Process Variable Display Decimal Places

| Display | |
|---------|---------|
| 0 | XXXX |
| 1 | XXX . X |
| 2 | XX . XX |
| 3 | X . XXX |

* Temperature inputs only

Fig. 4.3 Hardware Assignment and Input Type



4.3.2 Alarms and Set Point Types – Fig. 4.4

* **Note.** All relays are de-energised in the alarm state.

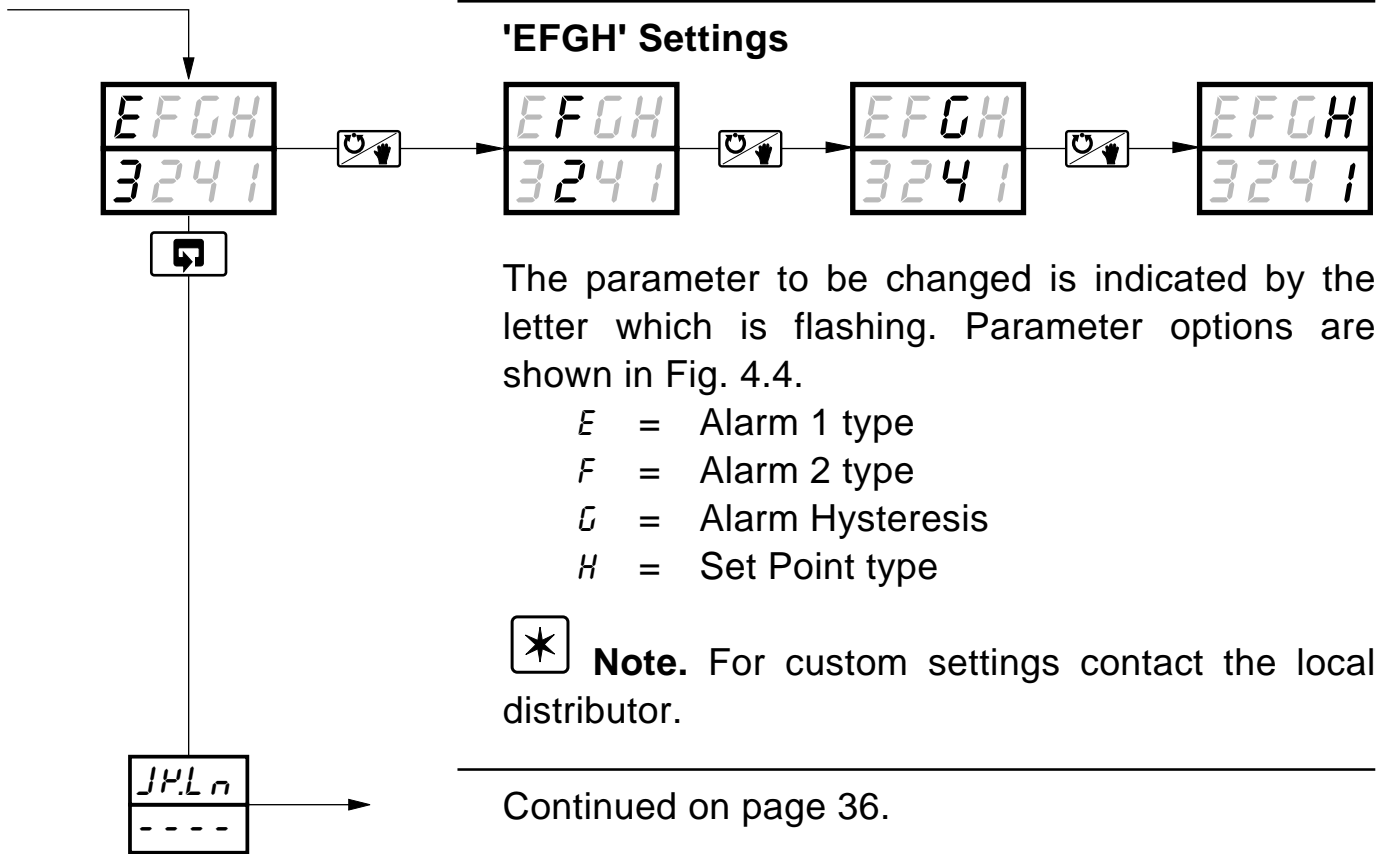

Continued on page 36.



EFGH
3241

E – Alarm 1 Type*

| Display | |
|---------|----------------|
| 0 | None |
| 1 | High Process |
| 2 | Low Process |
| 3 | High Deviation |
| 4 | Low Deviation |
| 5 | Loop Break |

EFGH
3241

F – Alarm 2 Type*

| Display | |
|---------|----------------|
| 0 | None |
| 1 | High Process |
| 2 | Low Process |
| 3 | High Deviation |
| 4 | Low Deviation |
| 5 | Loop Break |

* Refer to Figs. 4.5 and 4.6 for alarm action

EFGH
3241

G – Alarm Hysteresis

| Display | |
|---------|--------|
| 0 | None |
| 1 | 0.1% |
| 2 | 0.2% |
| 3 | 0.5% |
| 4 | 1.0% |
| 5 | 2.0% |
| 6 | 5.0% |
| U | Custom |

} Value in % of engineering range

Value in engineering units *₁

* **Note 1.** When custom alarm hysteresis is selected, the alarm hysteresis values are set individually in the set up level – see section 3.3

EFGH
3241

H – Set Point Type

| Display | |
|---------|--|
| 0 | Local Set Point Only |
| 1 | Local + Remote Set Point (no Remote Set Point Tracking)** * ₂ |
| 2 | Local + Remote Set Point (with Remote Set Point Tracking)** |
| 3 | Multiple Fixed Set Points |
| 4 | Ramp/Soak (Time Units in Minutes) |
| 5 | Ramp/Soak (Time Units in Hours) |

**Only available if option board is fitted. Remote set point input is 4 to 20 mA

* **Note 2.** With remote set point tracking enabled the local set point tracks the remote set point when in the remote set point mode.

Fig. 4.4 Alarms and Set Point Types



...4.3.2 Alarms and Set Point Types – Fig. 4.4



Note. All relays are de-energised in the alarm state.

Loop Break Alarm

The loop break alarm indicates a fault in the control loop (e.g. failure of a heating element in a furnace). If the control output remains at maximum or minimum for a time exceeding the trip value (in seconds) without any response in the process value, the loop break alarm is activated.

Process and Deviation Alarms (High/Low) – Figs 4.5 and 4.6

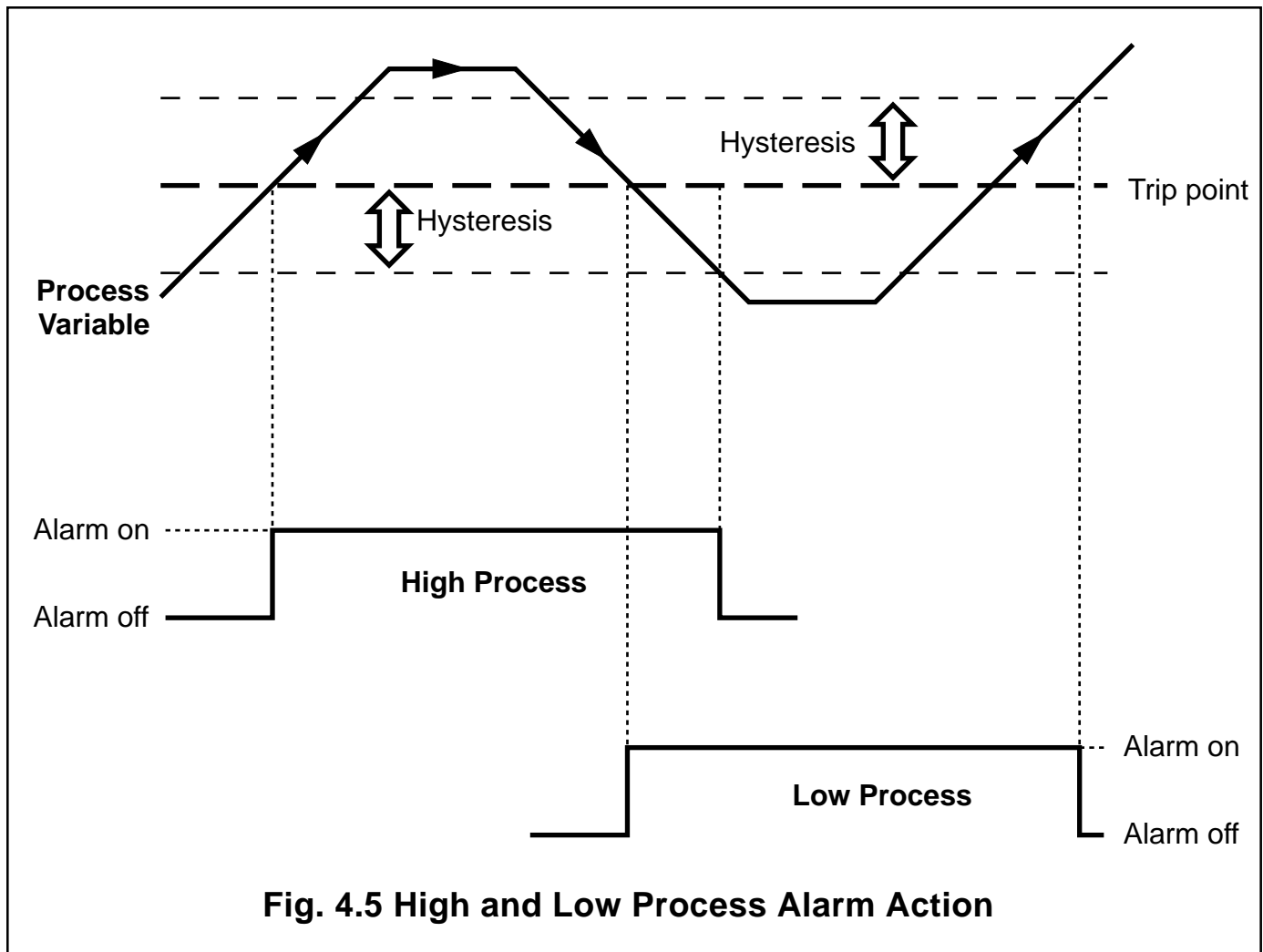

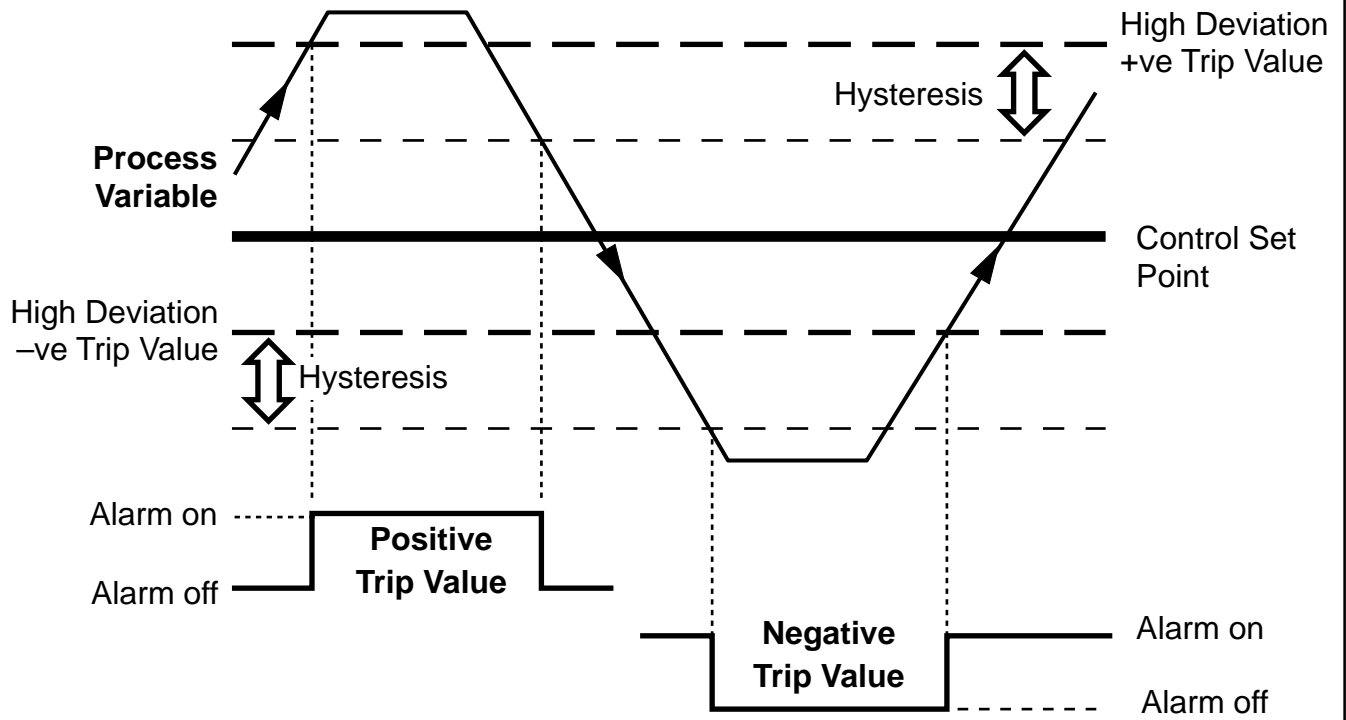

High Deviation Alarm

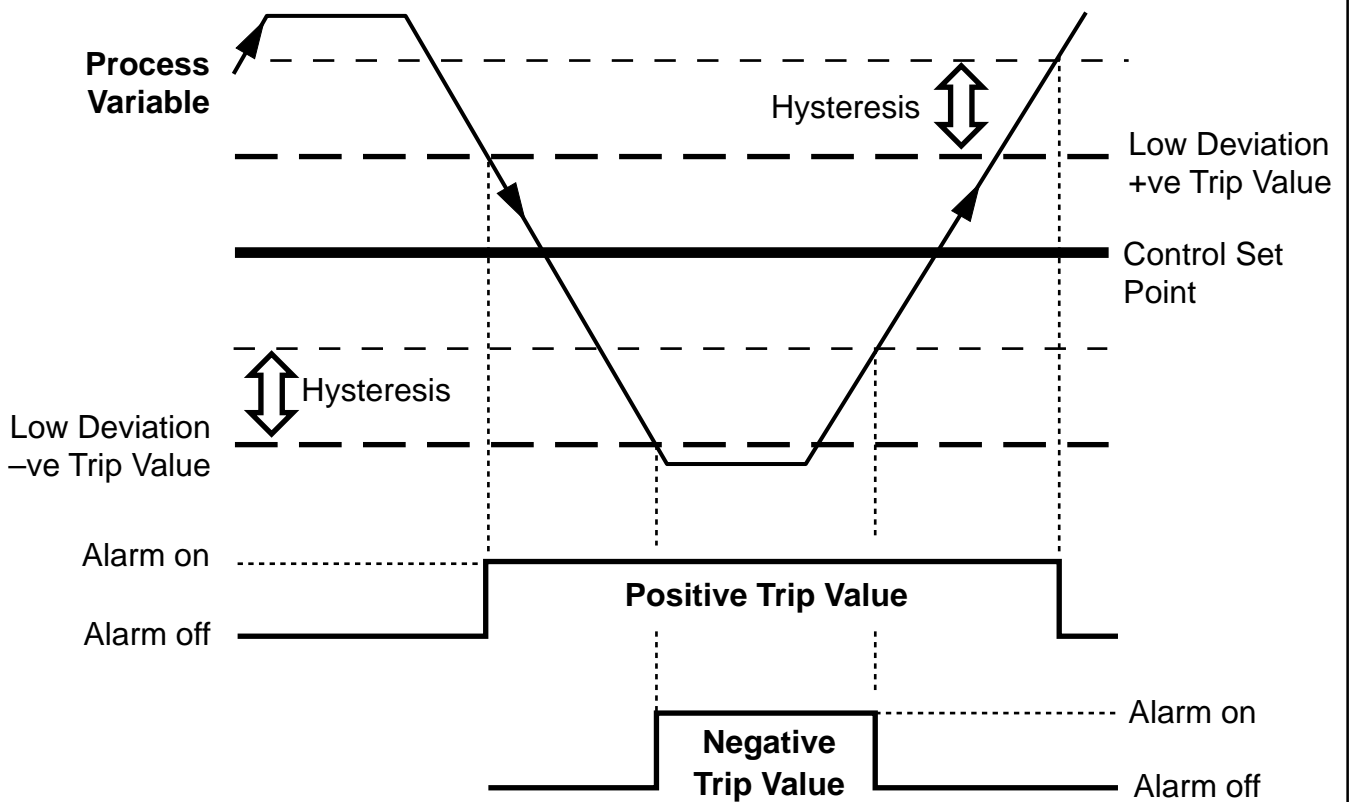

Low Deviation Alarm

Fig. 4.6 High and Low Deviation Alarm Action



...4 CONFIGURATION MODE

4.3.3 Operator Access and Control Action – Fig. 4.7

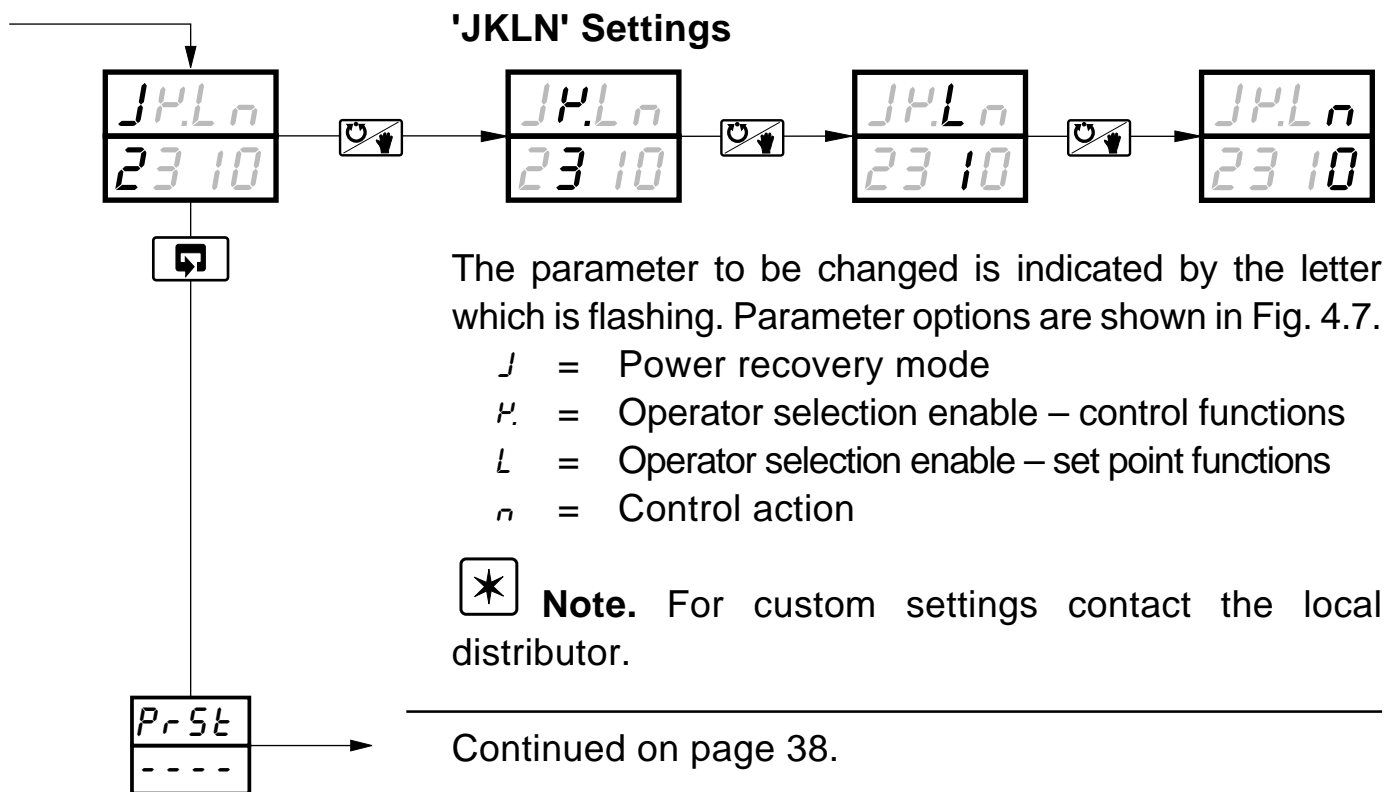



JPLn
23 10

J – Power Recovery Mode

| Display | Mode |
|---------|---------------------------|
| 0 | Last Mode |
| 1 | Manual with Last Output |
| 2 | Manual with 0.0% Output |
| 3 | Manual with 100.0% Output |
| 4 | Auto |
| U | Custom |

JPLn
23 10

K – Operator Selection Enable Control Functions

| Display | Auto/Manual and Autotune |
|---------|-------------------------------|
| 0 | Enable Both Functions |
| 1 | Disable A/M, Enable Auto-tune |
| 2 | Enable A/M, Disable Auto-tune |
| 3 | Disable Both Functions |

JPLn
23 10

L – Operator Selection Enable – Set Point Functions

| Display | Local Set Point Adjustment and Local/Remote Set Point Selection |
|---------|---|
| 0 | Enable Both Functions |
| 1 | Disable Set Point Adjust, Enable Local/Remote Selection |
| 2 | Enable Set Point Adjust, Disable Local Remote Function |
| 3 | Disable Both Functions |

JPLn
23 10

N – Control Action

| Display | Heat Action | Cool Action |
|---------|-------------|-------------|
| 0 | Reverse | Direct |
| 1 | Direct | Reverse |

Fig. 4.7 Operator Access and Control Action



4.3.4 Digital Input and Serial Communications – Fig. 4.8

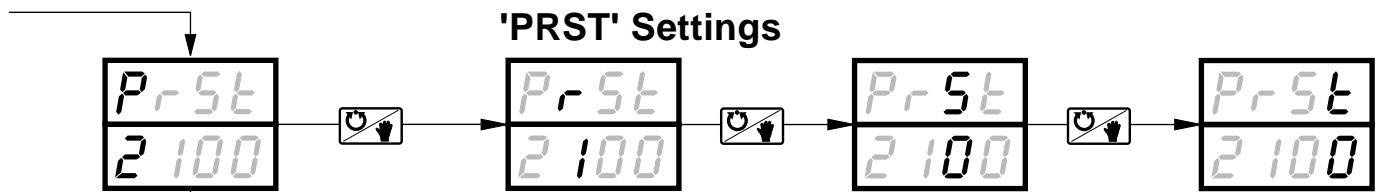

The parameter to be changed is indicated by the letter which is flashing. Parameter options are shown in Fig. 4.8.

- P* = Digital input function
- r* = Analog input digital filter
- S* = Serial communications configuration
- t* = Serial communication parity

Note. For custom settings contact the local distributor.

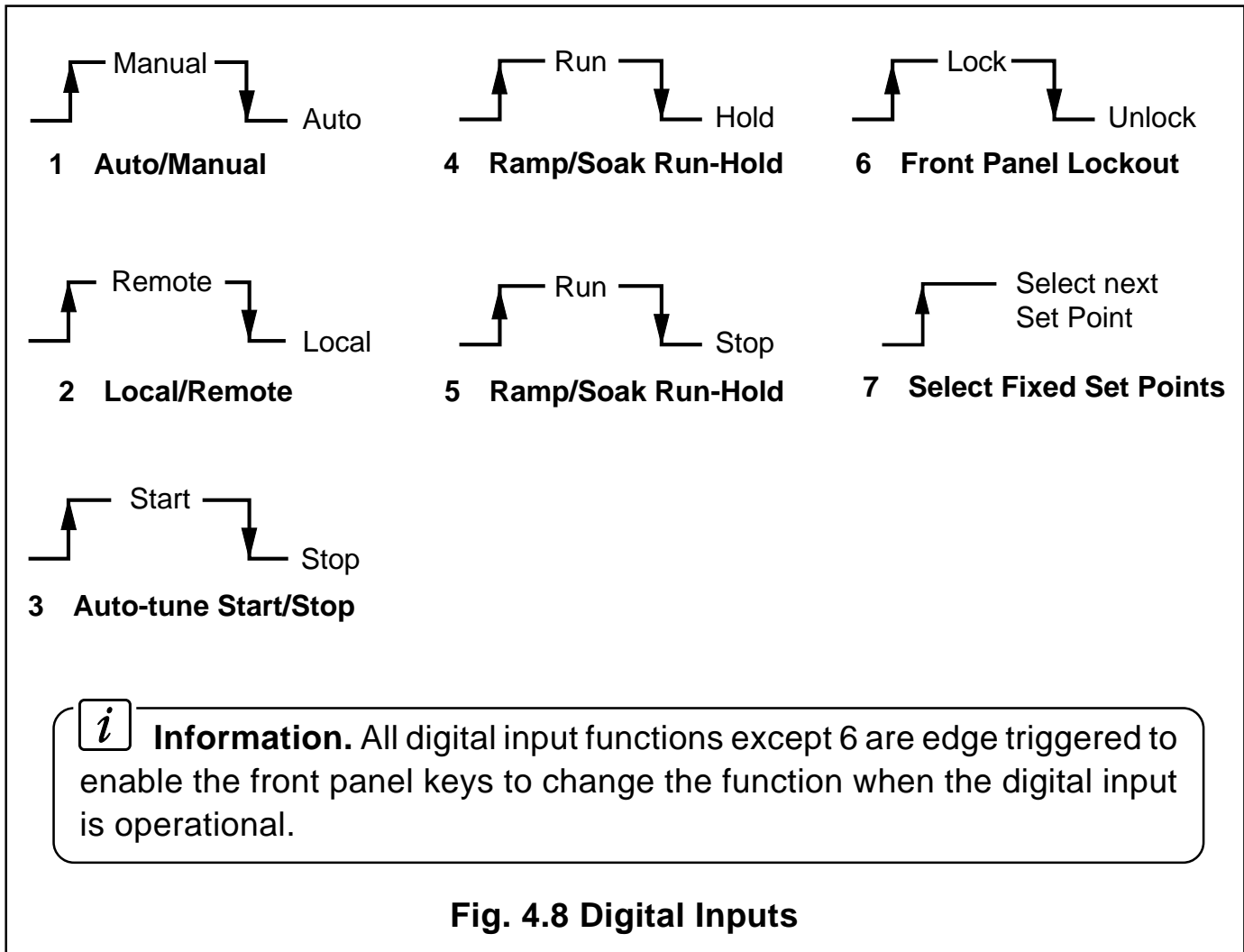

Fig. 4.8 Digital Inputs



P – Digital Input Functions

| Display | Function |
|---------|-------------------------|
| 0 | None |
| 1 | Auto/Manual |
| 2 | Local/Remote |
| 3 | Auto-tune Start |
| 4 | Ramp/Soak Run-Hold |
| 5 | Ramp/Soak Run-Stop |
| 6 | Front Panel Lockout |
| 7 | Select Fixed Set Points |



R – Analog Input Digital Filter

| Display | |
|---------|------------|
| 0 | 0 seconds |
| 1 | 1 second |
| 2 | 2 seconds |
| 5 | 5 seconds |
| A | 10 seconds |
| B | 20 seconds |
| C | 40 seconds |
| D | 60 seconds |

Input filter averages the process variable input values over the time set



S – Serial Communication Configuration

| Display | Baud Rate, 2/4 Wire |
|---------|---------------------|
| 0 | Off |
| 1 | 2400, 2 Wire |
| 2 | 2400, 4 Wire |
| 3 | 9600, 2 Wire |
| 4 | 9600, 4 Wire |

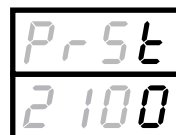

T – Serial Communications Parity

| Display | |
|---------|------|
| 0 | None |
| 1 | Odd |
| 2 | Even |

Fig. 4.9 Digital Input and Serial Communications



4.4 Ranges and Passwords (Level 6)

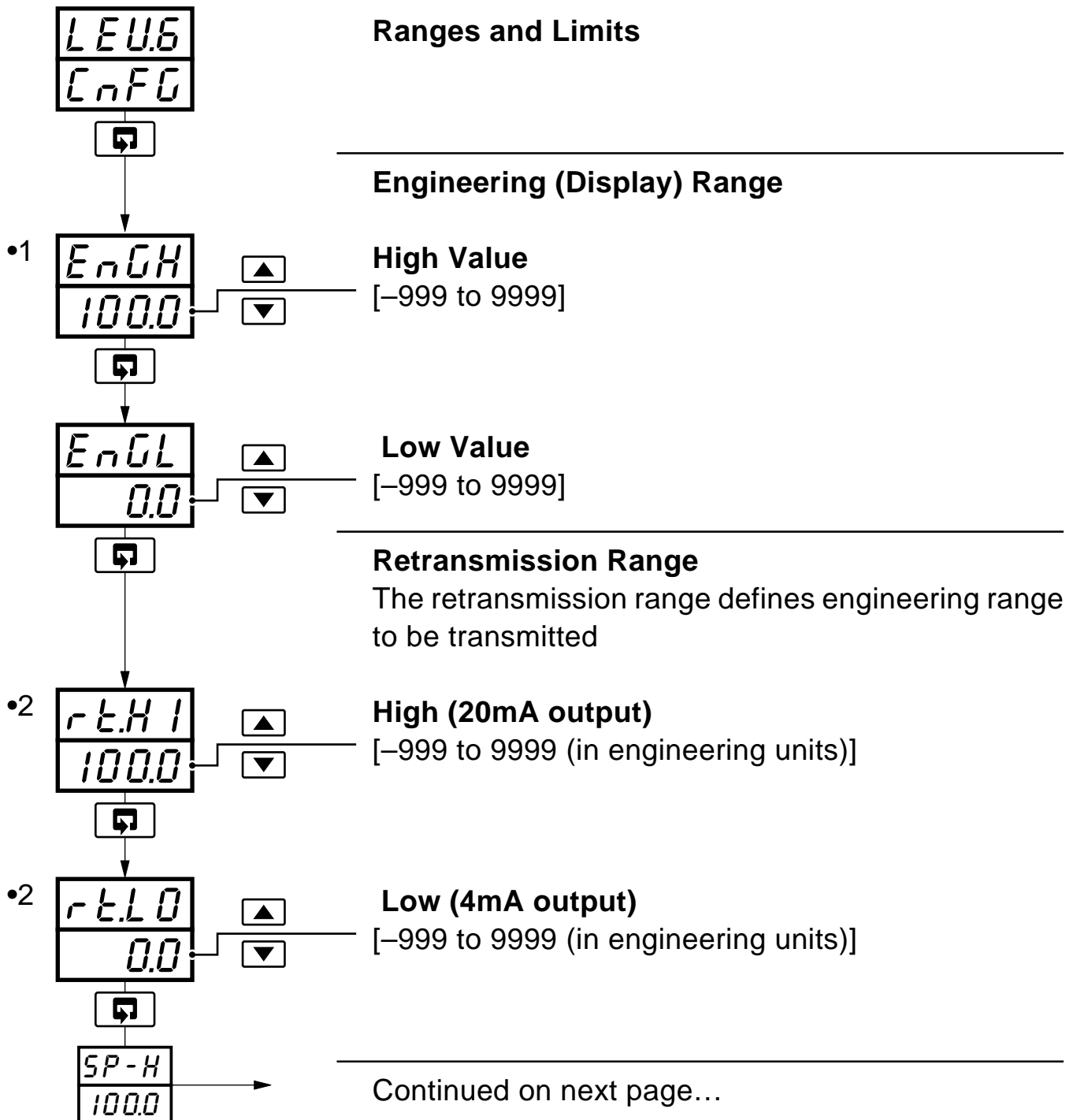

- 1 The engineering range high and low values are automatically set to the maximum allowed value when thermocouple or RTD is selected in the configuration level – see Section 4.3.1. This value can be modified if required.
- 2 Only displayed if the analog output is configured to retransmit the process variable or control set point value.



...4.4 Ranges and Passwords (Level 6)

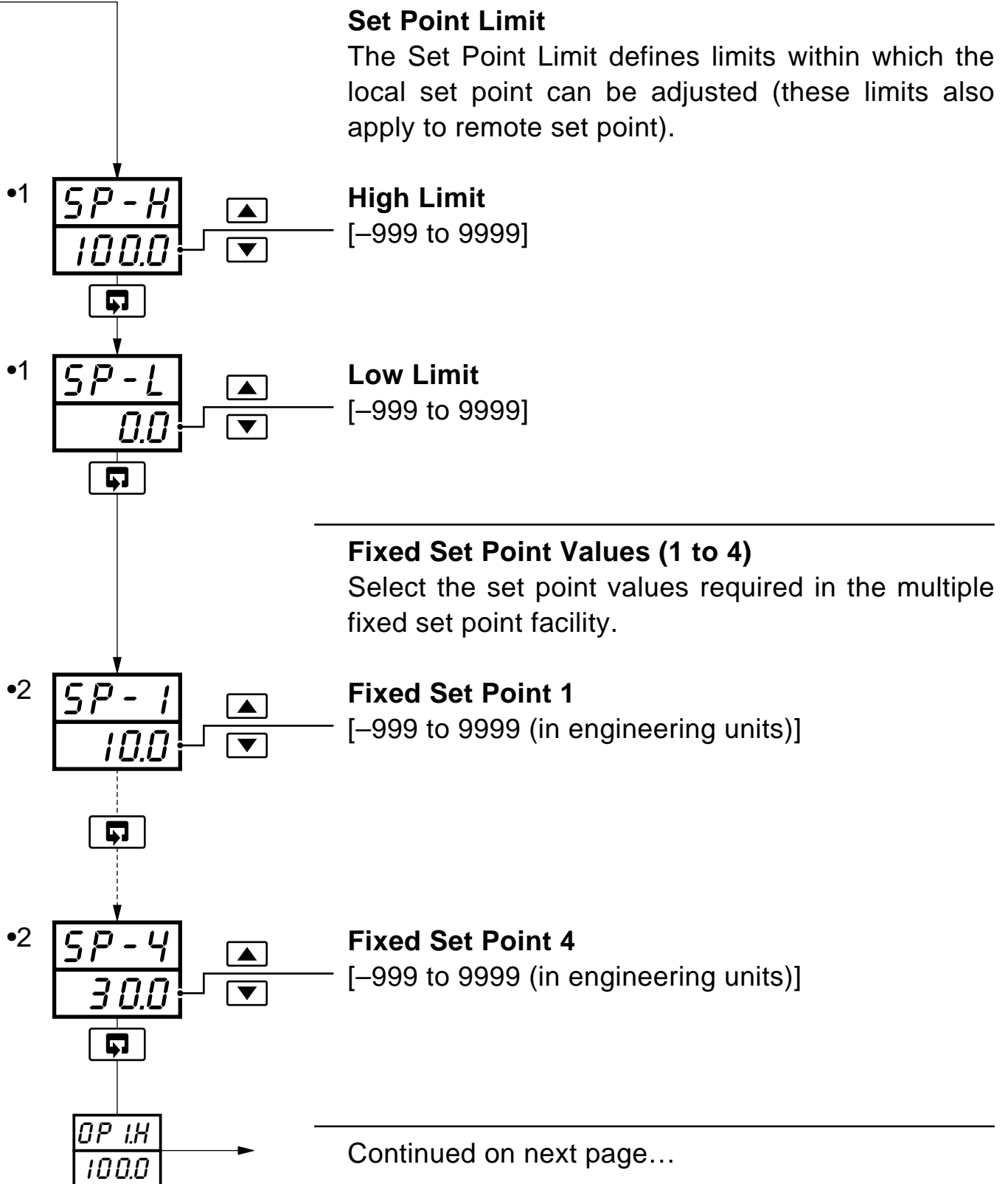

- 1 This limit applies to the local and remote set point values.
- 2 Only displayed if the multiple fixed set point facility is selected.



...4 CONFIGURATION MODE

...4.4 Ranges and Passwords (Level 6)

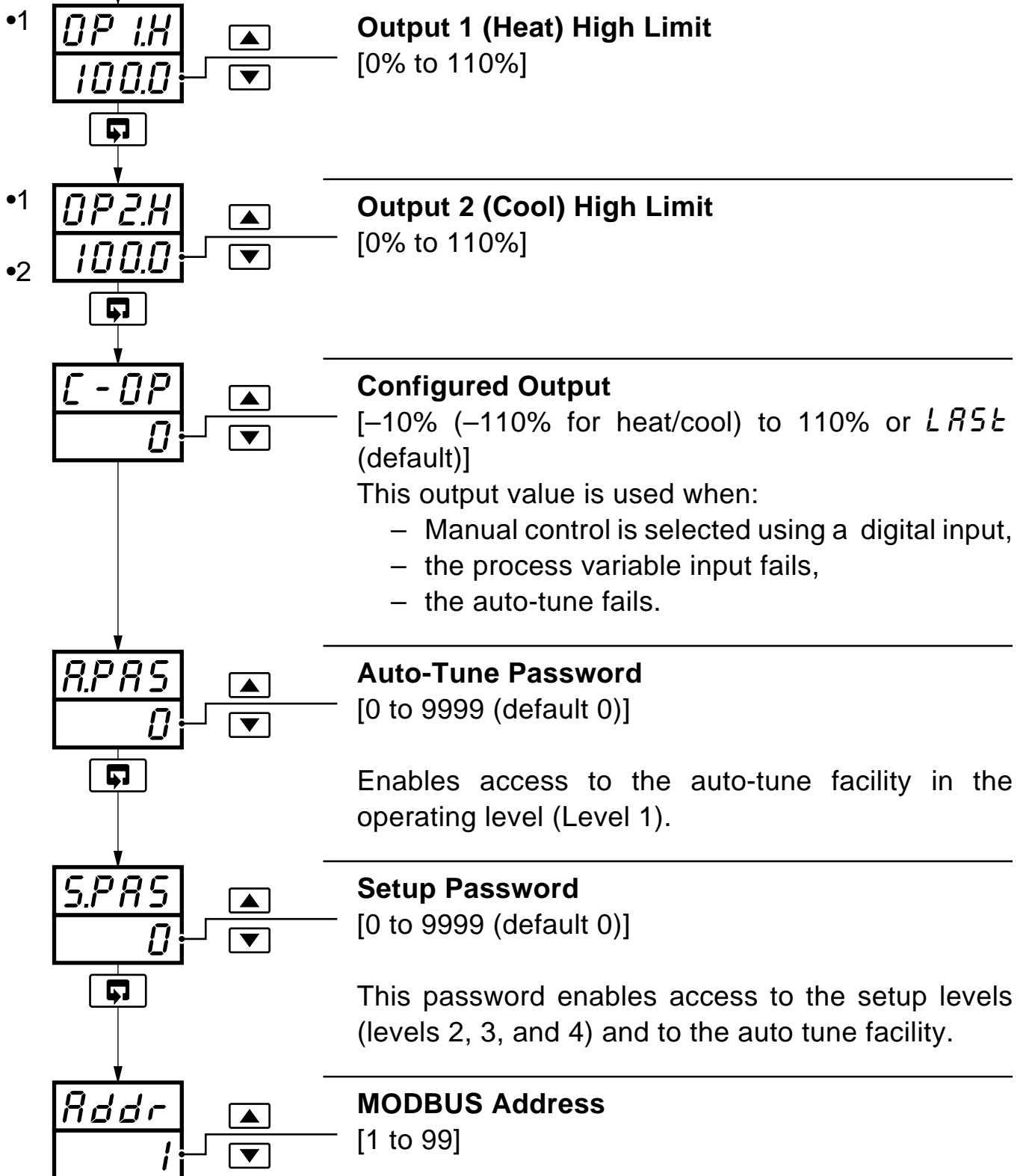

This frame allows the Modbus address to be set.

- 1 This value only applies in automatic mode.
The low limit is automatically set to 0.0% (-10% for analog outputs).
- 2 Only displayed if a heat/cool hardware configuration is selected.

5 INSTALLATION



5.1 Siting – Figs. 5.1 and 5.2

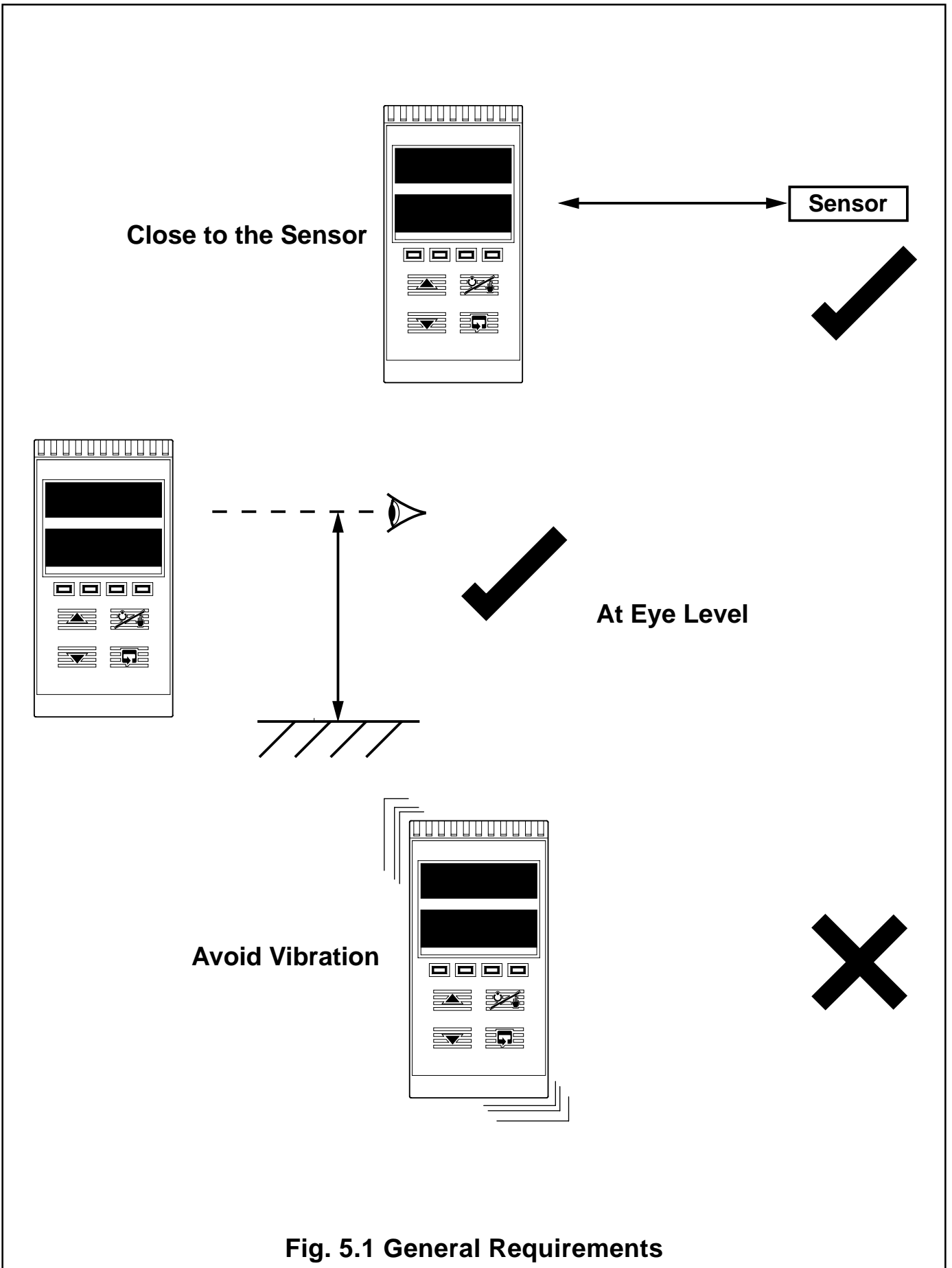
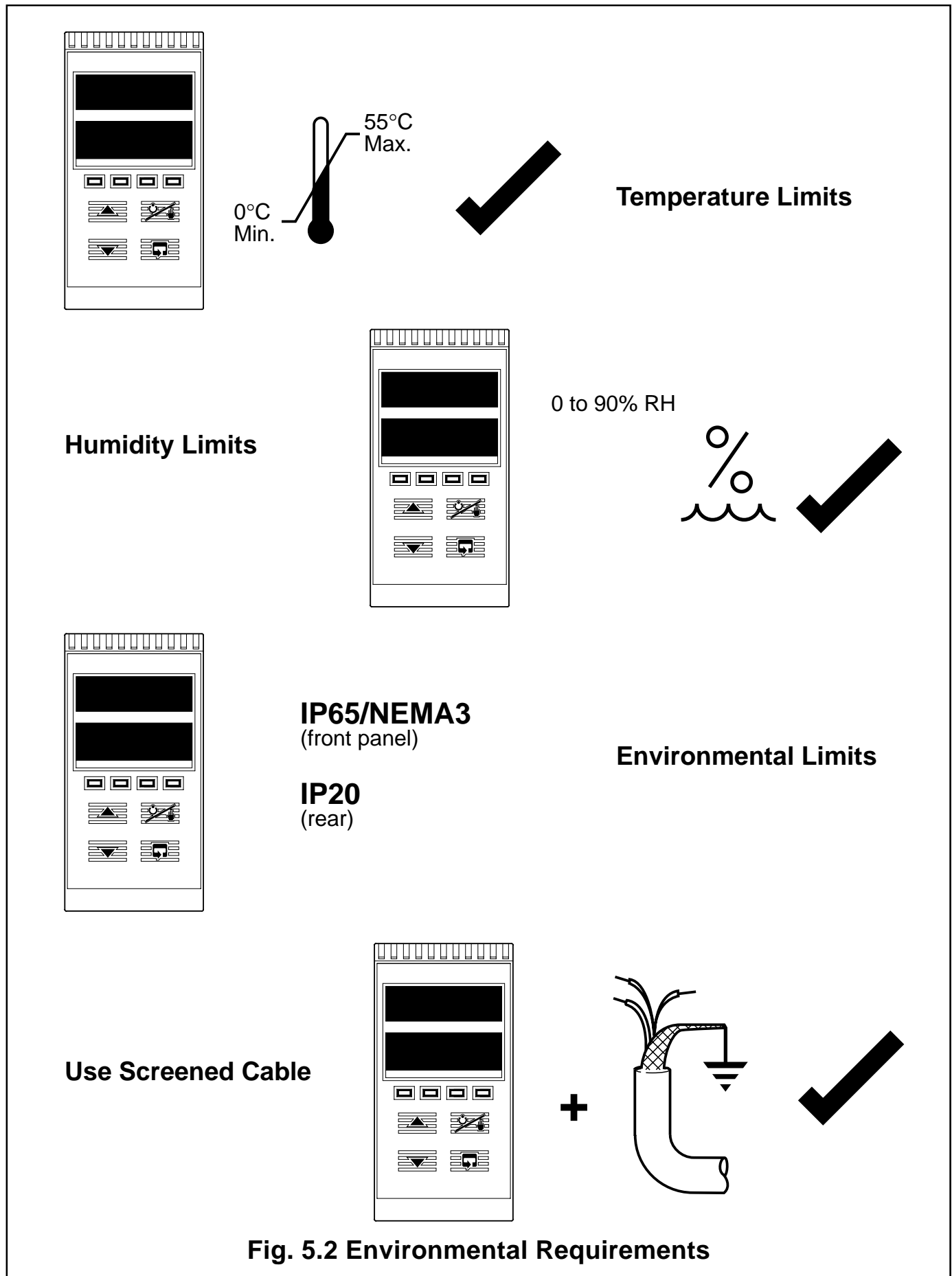

Fig. 5.1 General Requirements



...5 INSTALLATION

...5.1 Siting – Figs. 5.1 and 5.2





5.2 Mounting – Figs. 5.3 and 5.4

The instrument is designed for panel mounting (see Fig. 5.4). Overall dimensions are shown in Fig. 5.3.

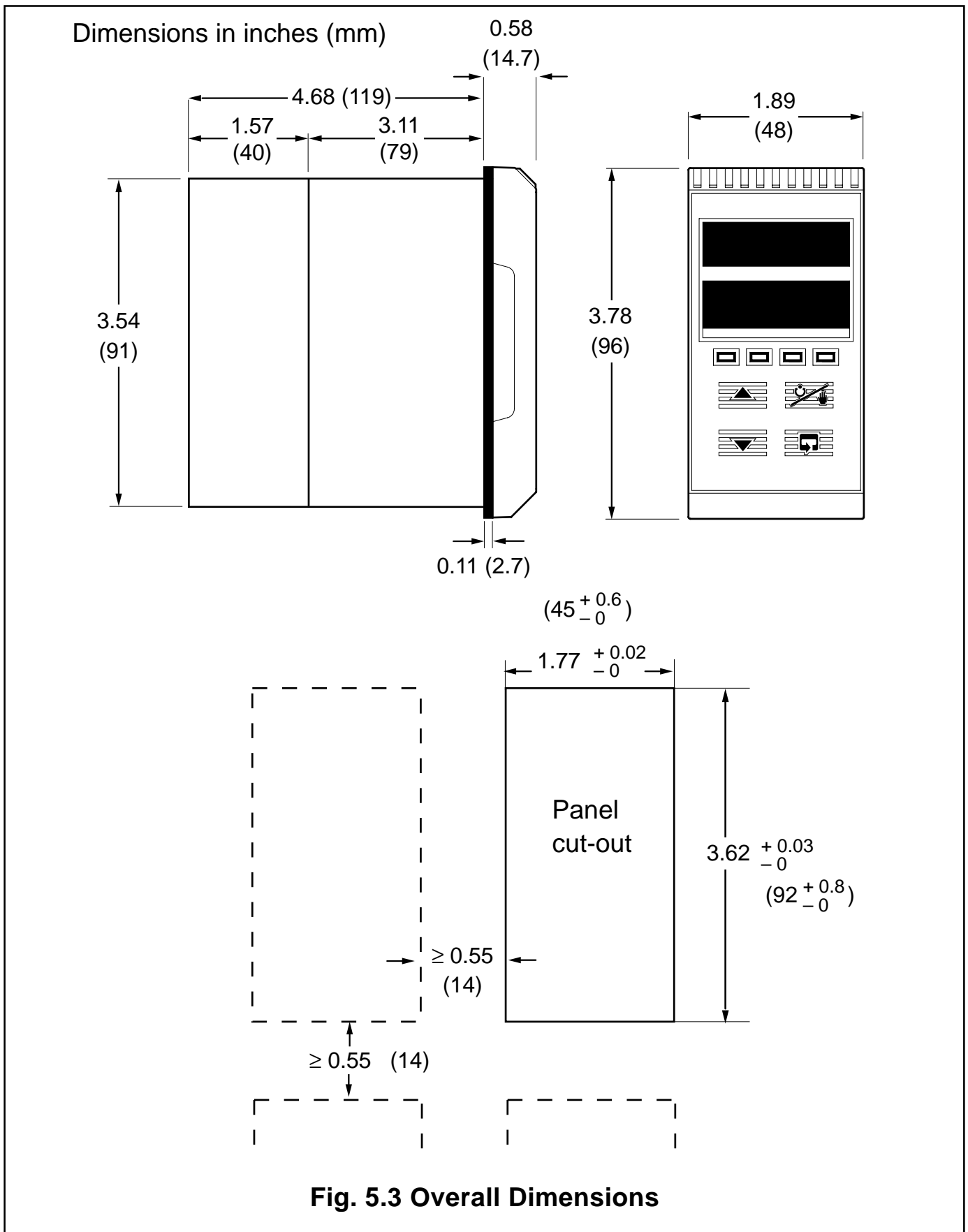



...5 INSTALLATION

...5.2 Mounting – Figs. 5.3 and 5.4

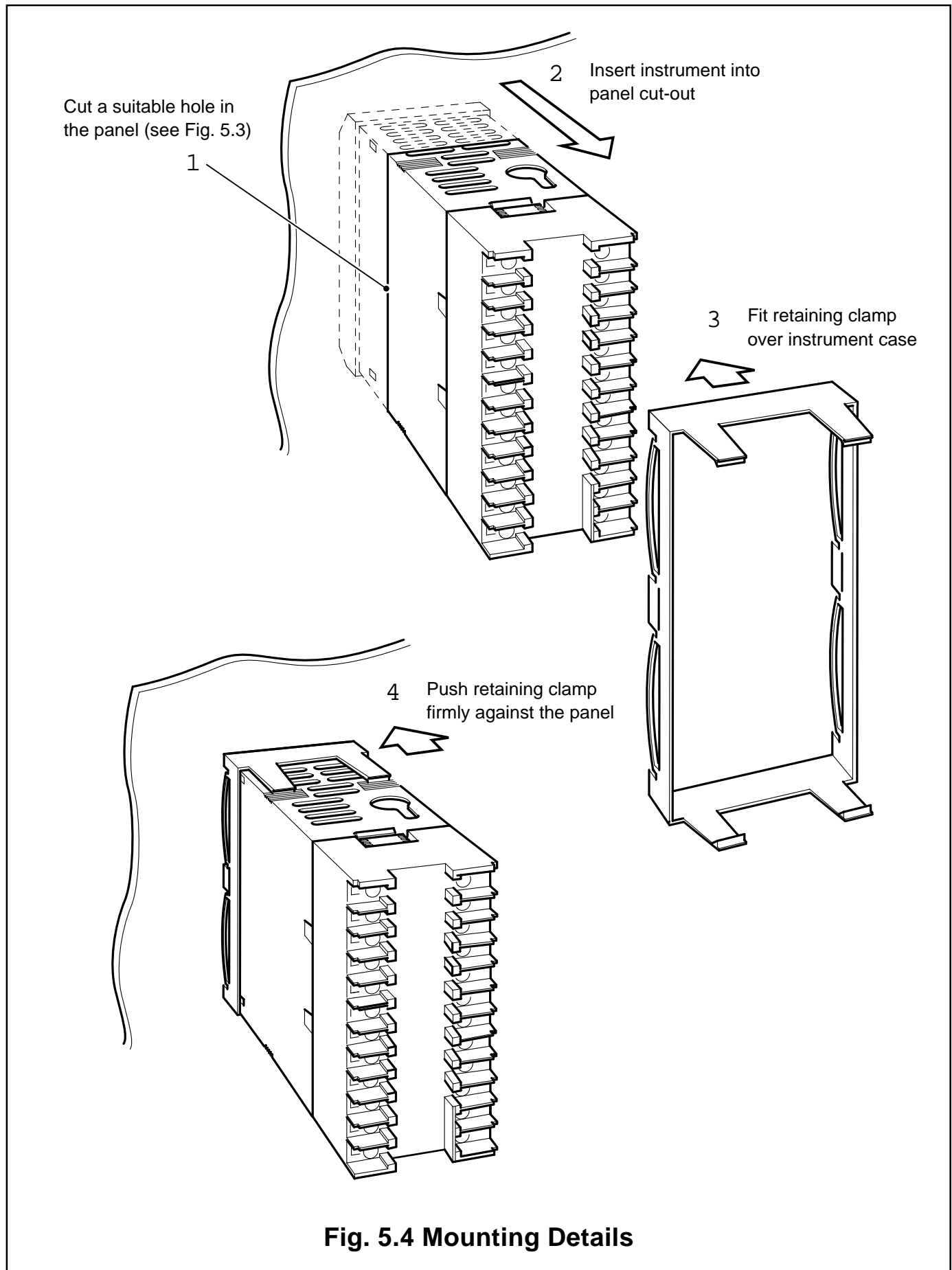

Fig. 5.4 Mounting Details



EC Directive 89/336/EEC

In order to meet the requirements of the EC Directive 89/336/EEC for EMC regulations, this product must not be used in a non-industrial environment.

5.3 Electrical Connections – Fig. 5.5 (overleaf)



Warning. Before making any connections, ensure that the power supply, any powered control circuits and high common mode voltages are switched off. The instrument must be connected in accordance with local regulations and have an external means of disconnection. External fuse rating must not exceed 5A.



Note. If it is not possible to avoid strong electrical and magnetic fields, screened cables within earthed metal conduit must be used.

5.4 Relays, Arc Suppression and Outputs

5.4.1 Relay Contact Ratings

Relay contacts are rated at:

115/230V AC at 5A (non-inductive).

250V DC 25W max.

5.4.2 Arc Suppression

Arc suppression components are fitted to relays 2 and 3 only. If relay 1 is required to switch inductive loads, fit the arc suppression components supplied.

5.4.3 Logic Output

18V DC at 20mA.

Min load 900Ω.

Isolation from Analog Output (not isolated from Retransmission Output). Dielectric strength – 500V d.c. for 1 minute.

5.4.4 Control or Retransmission Analog Outputs

Max. load 15V (750Ω at 20mA).

Isolation from Analog Output (not isolated from Logic Output). Dielectric strength – 500V d.c. for 1 minute.

5.4.5 Digital Input

Type: Volt-free

Minimum Pulse: 250ms



...5 INSTALLATION

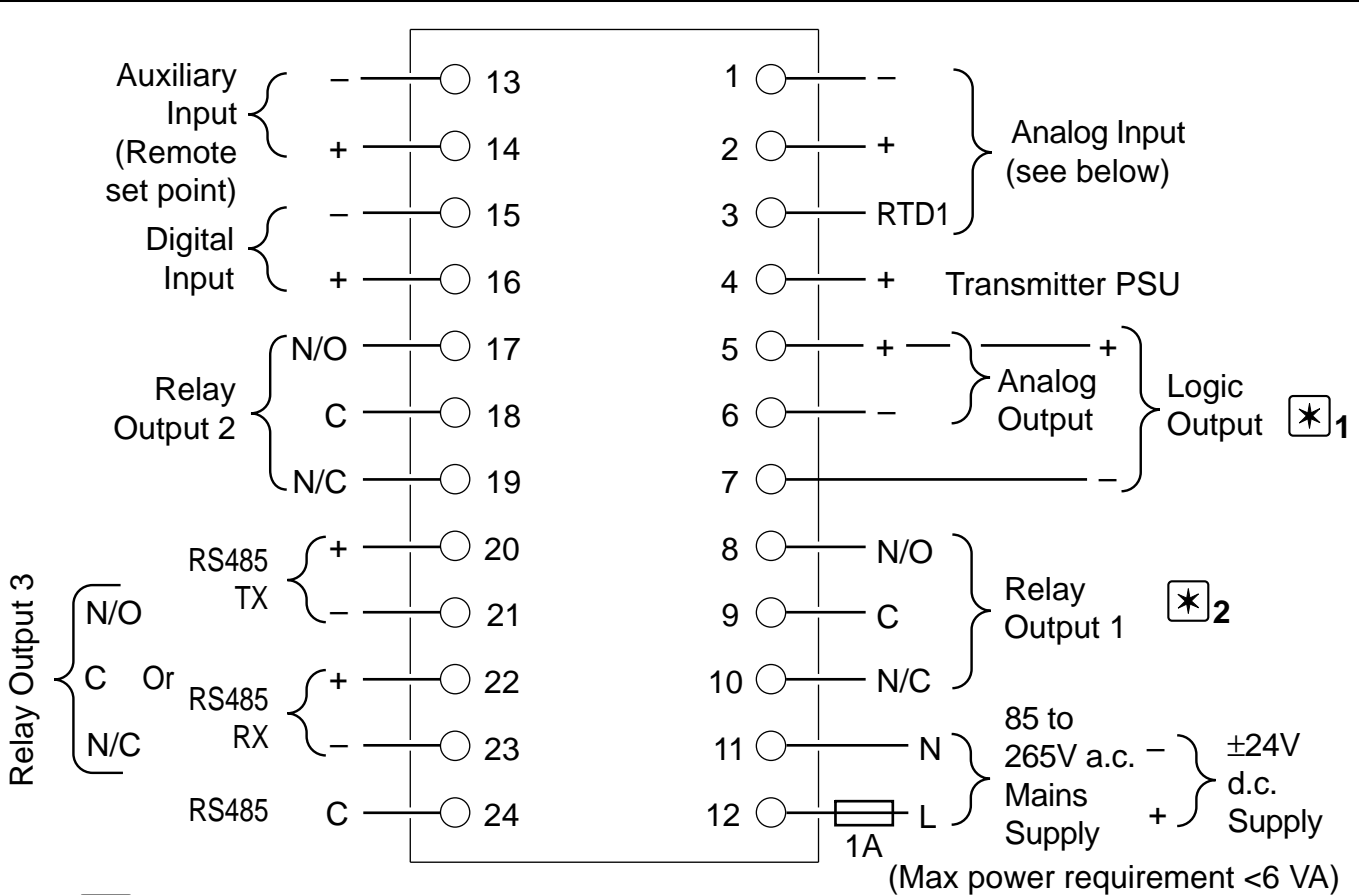

*** Note 1.** The Analog Output and Logic Output use a common positive terminal that is capable of driving both outputs simultaneously.

*** Note 2.** Fit arc suppression components if switching inductive loads.

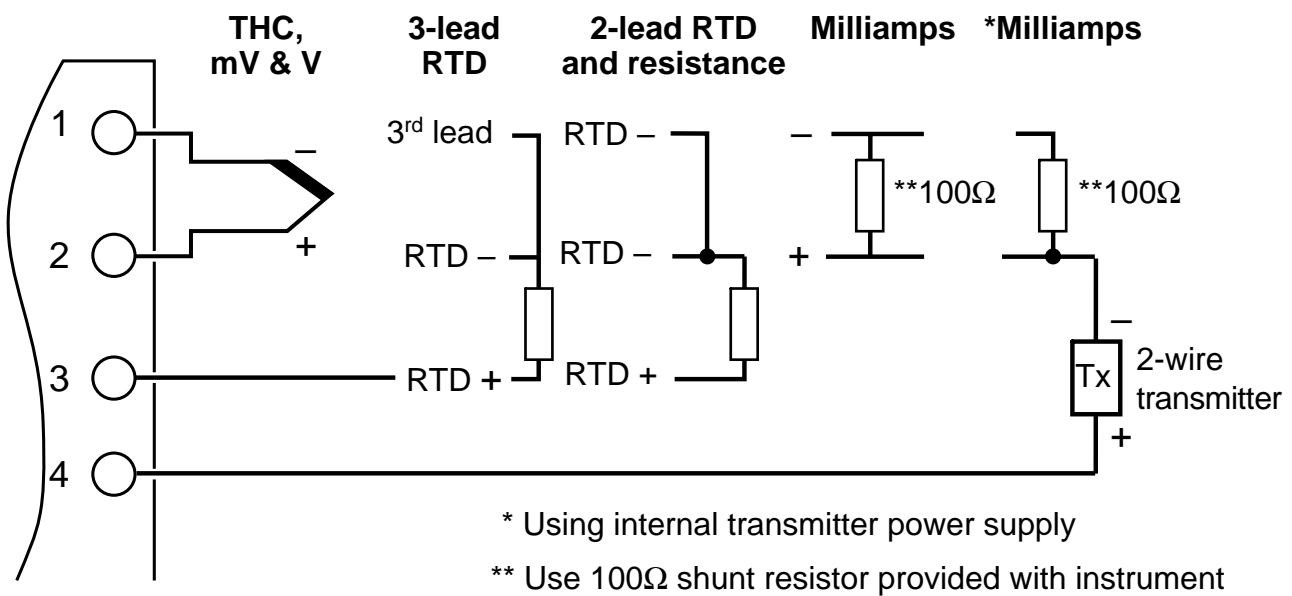
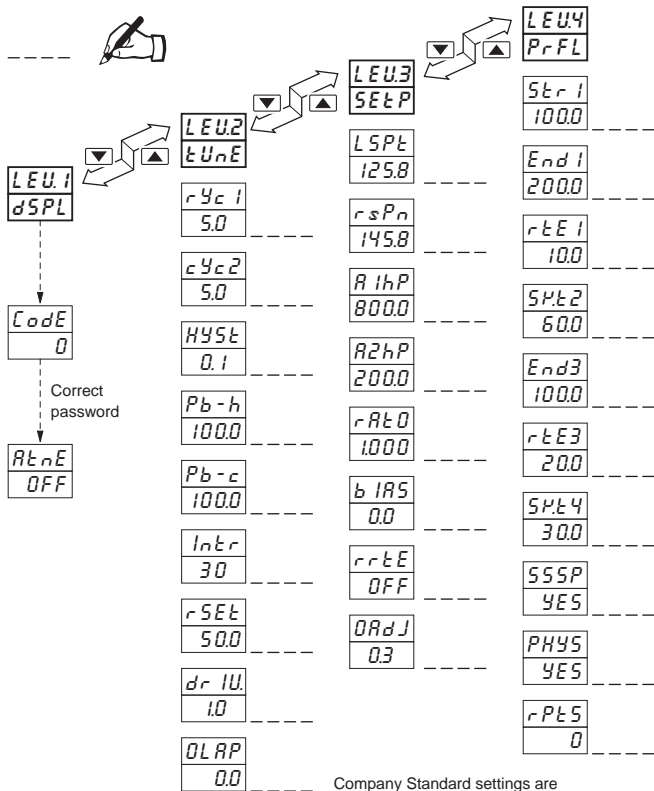

Fig. 5.5 Electrical Connections

CUSTOMER SETUP LOG



Instrument Serial Number: _____

Product Code: C 1 0 0 / _ _ _ _ / _ _ _ _



CUSTOMER CONFIGURATION LOG



LEU.S
CnFG

RbCd

EFGH

JPLn

PrSt

LEU.S
CnFG

EnGH
1000

EnGL
00

rLH1
1000

rLL0
00

SP-H
1000

SP-L
00

SP-1
100

SP-2
200

SP-3
300

SP-4
400

OP1H
100

OP2H
100

C-OP
0

RPAS
0

SPAS
0

Rddr
1

Company Standard settings are shown in the lower display

Customer Support

ABB Ltd provides a comprehensive after sales service via our Worldwide Service Organization. Contact one of the following offices for details of your nearest Service and Repair Centre.

United Kingdom

ABB Ltd

Tel: +44 (0)1480 475 321

Fax: +44 (0)1480 470 787

United States of America

ABB Automation Inc.

Instrumentation Division

Tel: +1 215 674 6000

Fax: +1 215 674 7183

Client Warranty

Prior to installation, the equipment referred to in this manual must be stored in a clean, dry environment, in accordance with the Company's published specification. Periodic checks must be made on the equipment's condition.

In the event of a failure under warranty, the following documentation must be provided as substantiation:

1. A listing evidencing process operation and alarm logs at time of failure.
2. Copies of operating and maintenance records relating to the alleged faulty unit.



The Company's policy is one of continuous product improvement and the right is reserved to modify the information contained herein without notice.

© ABB 2001

Printed in UK (11.01)

ABB Ltd
Howard Road, St. Neots
Cambridgeshire, PE19 8EU
UK
Tel: +44 (0)1480 475 321
Fax: +44 (0)1480 470 787

ABB Automation Inc
125 E. County Line Road
Warminster, PA 18974
USA
Tel: +1 215 674 6000
Fax: +1 215-674 7183

ABB has Sales & Customer Support expertise
in over 100 countries worldwide

www.abb.com