

HART Pressure Transmitters

Models 262H/N/G/A

Models 264H/N/G/A



The Company

ABB Automation is an established world force in the design and manufacture of instrumentation for industrial process control, flow measurement, gas and liquid analysis and environmental applications.

As a part of ABB, a world leader in process automation technology, we offer customers application expertise, service and support worldwide.

We are committed to teamwork, high quality manufacturing, advanced technology and unrivalled service and support.

The quality, accuracy and performance of the Company's products result from over 100 years experience, combined with a continuous program of innovative design and development to incorporate the latest technology.

The NAMAS Calibration Laboratory No. 0255(B) is just one of the ten flow calibration plants operated by the Company, and is indicative of ABB Automation's dedication to quality and accuracy.

BS EN ISO 9001



St Neots, U.K. – Cert. No. Q5907
Stonehouse, U.K. – Cert. No. FM 21106

UNI EN ISO 9001



Lenno, Italy – Cert. No. 9/90A



Stonehouse, U.K. – Cert. No. 0255

Use of Instructions



Warning.

An instruction that draws attention to the risk of injury or death.



Note.

Clarification of an instruction or additional information.



Caution.

An instruction that draws attention to the risk of damage to the product, process or surroundings.



Information.

Further reference for more detailed information or technical details.

Although **Warning** hazards are related to personal injury, and **Caution** hazards are associated with equipment or property damage, it must be understood that operation of damaged equipment could, under certain operational conditions, result in degraded process system performance leading to personal injury or death. Therefore, comply fully with all **Warning** and **Caution** notices.

Information in this manual is intended only to assist our customers in the efficient operation of our equipment. Use of this manual for any other purpose is specifically prohibited and its contents are not to be reproduced in full or part without prior approval of Technical Communications Department, ABB Automation.

Health and Safety

To ensure that our products are safe and without risk to health, the following points must be noted:

1. The relevant sections of these instructions must be read carefully before proceeding.
2. Warning labels on containers and packages must be observed.
3. Installation, operation, maintenance and servicing must only be carried out by suitably trained personnel and in accordance with the information given. Any deviation from these instructions, will transfer the complete liability to the user.
4. Normal safety precautions must be taken to avoid the possibility of an accident occurring when operating in conditions of high pressure and/or temperature.
5. Chemicals must be stored away from heat, protected from temperature extremes and powders kept dry. Normal safe handling procedures must be used.
6. When disposing of chemicals ensure that no two chemicals are mixed.

Safety advice concerning the use of the equipment described in this manual or any relevant hazard data sheets (where applicable) may be obtained from the Company address on the back cover, together with servicing and spares information.

CONTENTS

Section	Page
INTRODUCTION	3
TRANSPORT, STORAGE, HANDLING AND PRODUCT IDENTIFICATION	4
PRINCIPLE OF OPERATION	5
INSTALLATION	7
ELECTRICAL CONNECTIONS	9
ELECTRICAL REQUIREMENTS	11
RANGE AND SPAN CONSIDERATION	11
CALIBRATION	12
DISMANTLING AND REASSEMBLY	14
SIMPLE FAULT FINDING	16
RETURNING FORM	17
ADDENDUM FOR "METERS" OPTION OF THE TRANSMITTERS	18
ADDENDUM FOR COMETER - ANALOG LCD INDICATOR WITH HART PROGRAMMING CAPABILITY	26
ADDENDUM FOR PV-SCALING OPERATION	31
ADDENDUM FOR "SURGE PROTECTOR" OPTION OF THE TRANSMITTERS	32
ADDENDUM USE OF HARDWARE LINKS ON THE SECONDARY ELECTRONICS	35
ADDENDUM FOR SELECTABLE OUTPUT FUNCTIONS	37
ADDENDUM FOR OUTPUT % RERANGING	40
ADDENDUM FOR "EX SAFETY" ASPECTS AND "IP" PROTECTION (EUROPE)	41

INTRODUCTION

The **2600T** series is a modular range of field mounted, micro-processor based electronic transmitters, using a unique inductive sensing element. The models here described are a pressure transmitter with "single port" process connection; this provides accurate and reliable measurement of gauge and absolute pressure, in the even most difficult and hazardous industrial environments.

The 2600T Smart series transmitter now includes Analog Version plus HART digital communication, a Profibus DP-PA Version and a Fieldbus FOUNDATION Version.

Digital communication protocols allow remote re-ranging, calibration and diagnostics.

With respect to HART, the bidirectional digital communication does not have any interference with the standard 4-20 mA analog output signal.

Profibus has a complete digital only communication, as well as Fieldbus FOUNDATION.

This manual describes the features, the installation and calibration procedures related to the 2600T Series Transmitter with HART Communication Protocol.

The 2600T series also gives the opportunity to utilize ceramic and silicon sensing elements, depending on measuring range and measured variable.

SUPPLEMENTARY DOCUMENTATION

Reference information on remote seals and configuration of the transmitter can be found in the following documents:

SS / S26	Remote Seal Specification
2600T	Data Sheets
SL/2600T	Spare Part List
IM / 691HT	Rev. 1 Hand-Held Communicator
Online HELP SMARTVISION Configuration Program	

TRANSPORT

After final calibration, the instrument is packed in a carton (Type 2 to ANSI/ASME N45.2.2-1978), intended to provide protection from physical damage.

STORAGE

The instrument does not require any special treatment if stored as despatched and within the specified ambient conditions level (Type 2 to ANSI/ASME N45.2.2-1978). There is no limit to the storage period, although the terms of guarantee remain as agreed with the Company and as given in the order acknowledgement.

HANDLING

The instrument does not require any special precautions during handling although normal good practice should be observed.

PRODUCT IDENTIFICATION

The instrument is identified by the data plates shown in Figure 1.

The Nameplate (ref.A) provides information concerning the code number, maximum process working pressure, range and span limits, power supply and output signal. This plate also shows the transmitter serial number.

Please refer to this number when making enquiries.

A dedicated label (ref. B) is welded as standard to the primary unit, carrying specific details of the transducer (diaphragms material, fill fluid, range limit and identification number).

A Safety Marking plate (ref. C) is fitted when the transmitter is required to comply with hazardous area regulations, e.g. flameproof or intrinsic safety protection. Additionally a wired-on type tag plate (ref. D) provides the customer tag number and calibrated range, maximum process working pressure (PS) and temperature (TS).

The instrument may be used as a safety accessory (category IV) as defined by the Pressure Equipment Directive 97/23/EC. In this case, near the CE mark, there is the number of the notified body (1130) that verified the compliance.

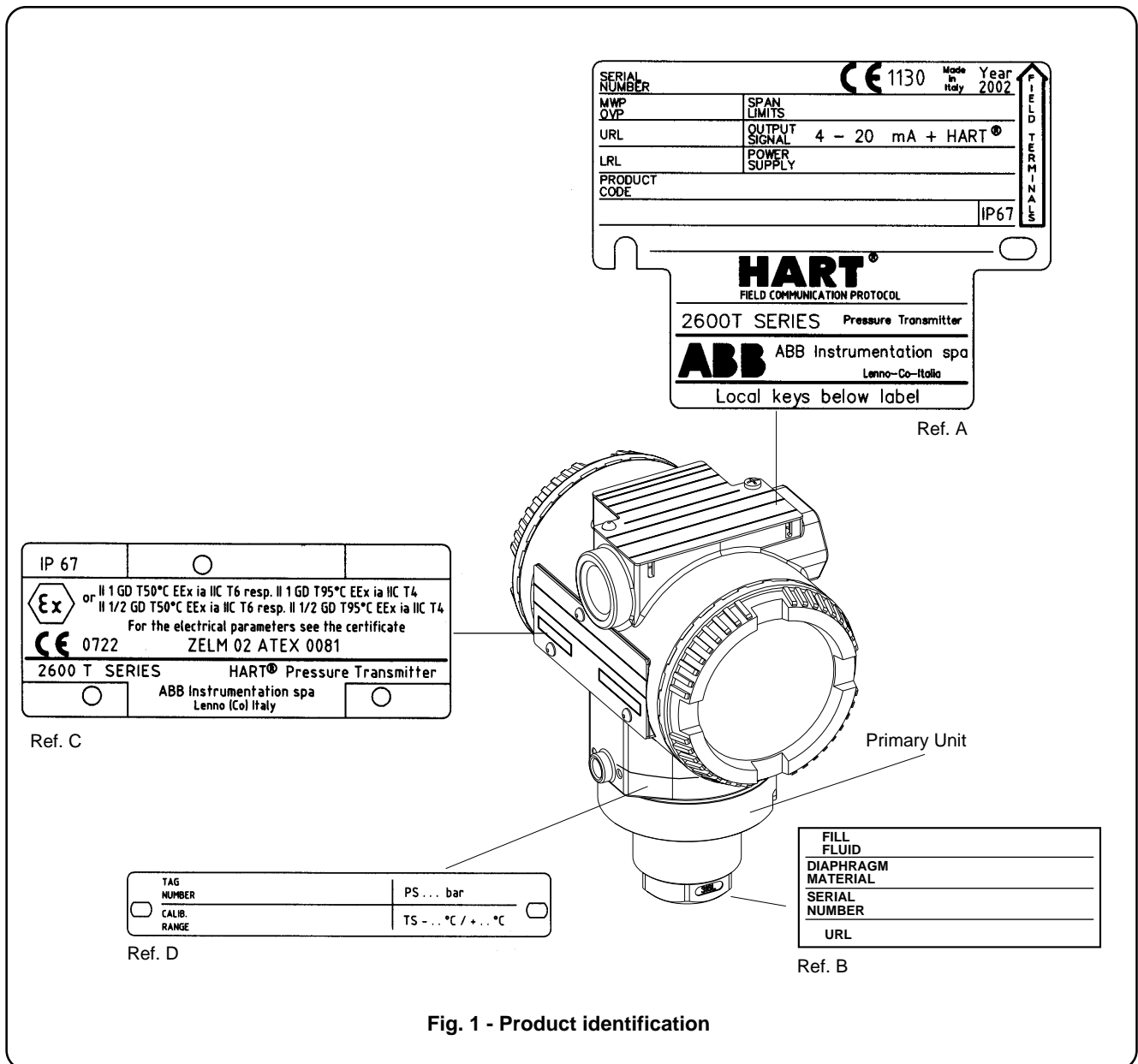

Fig. 1 - Product identification



Important - The instrument serial number must always be quoted when making enquiries.

PRINCIPLE OF OPERATION

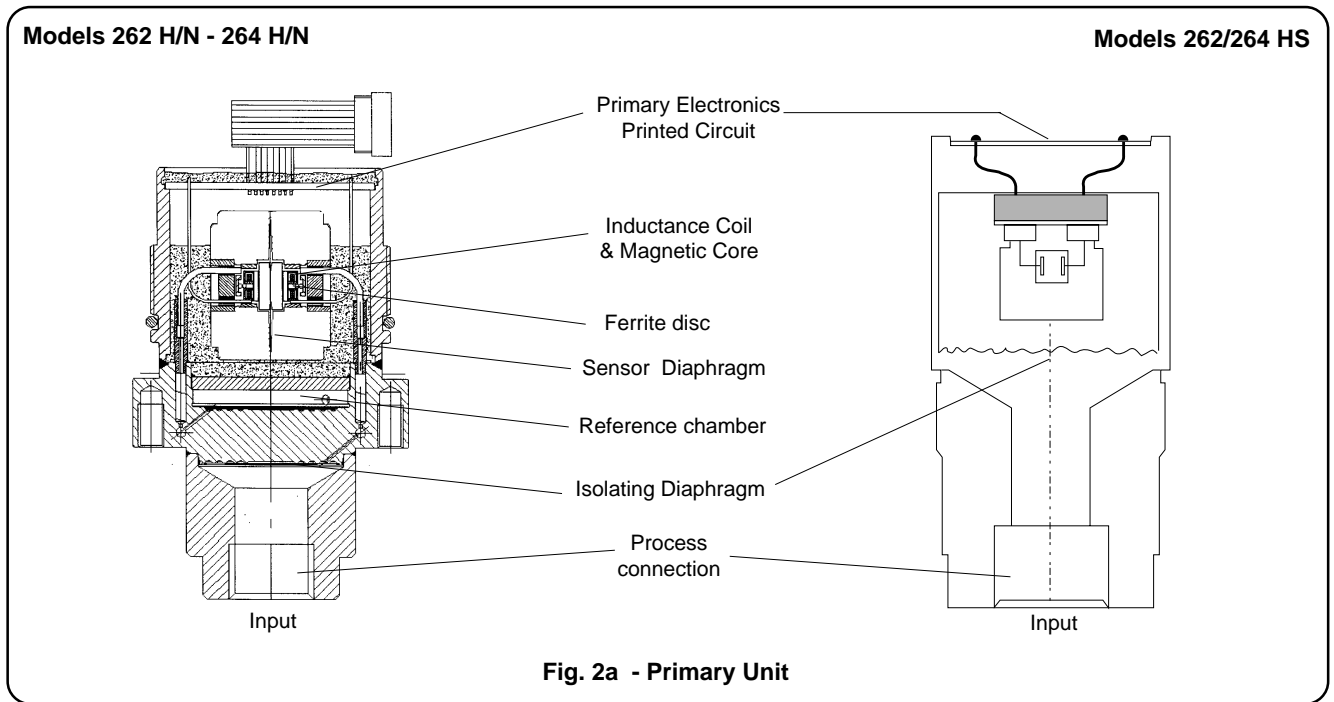

Fig. 2a - Primary Unit

The instrument consists of two functional units:

- Primary Unit
- Secondary Unit

The Primary Unit includes the process interface and the sensor, the Secondary Unit includes the electronics, the terminal block and the housing. The two units are mechanically coupled by a threaded joint. Electronics of Secondary Units is based on custom integrated components (Application Specific Integrated Circuit - ASIC).

The principle of operation of the Primary Unit, excluding model 420 bar (see later), is as follows. The process fluid (liquid, gas or vapour) exerts pressure on to the measuring diaphragm via flexible, corrosion-resistant isolating diaphragm and the fill fluid (see Fig. 2a). The other side of the measuring diaphragm is either at "atmosphere", for gauge measurement, or at "vacuum", for absolute measurement. As the measuring diaphragm deflects in response to input pressure changes, it simultaneously produces variations in the gap between the magnetic disc and the magnetic core of the coil, which is mounted rigidly on to the primary body. As a result, the inductance of the coil changes.

The inductance values of the coil is compared to that of a reference inductor carried by the primary electronics. The unit also includes a temperature sensor. The two inductance values and the sensor temperature, are combined in the primary electronics to provide a proprietary standard signal.

For the 420 bar model the principle is quite different because the sensor is a capacitive silicon sensor. Referring to fig. 2a (Range T- 420bar model) the pressure applied to the separating diaphragm is transferred to the filling fluid (typical silicon oil) acting directly on the silicon chip. The variation of capacitance is compared with a reference capacitance and it is converted in an electrical signal of the same type as for the inductance sensor. Consequently the further elaboration, together with

temperature signal is equivalent allowing to use the same secondary electronics.

In the manufacturing process the sensor output characteristics are compared with reference pressures and temperatures: the "mapped" parameters are then stored in EEPROM # 1.

Depending on measuring range and measured variable in other words, on the model, also a ceramic pressure sensor (Fig. 2b) and a silicon pressure sensor (Fig. 2c) can be adopted.

In case of the ceramic pressure sensor, the applied process pressure (p_e / pabs) is transferred directly to the measuring diaphragm, whereas, in case of the silicon pressure sensor, the pressure is transferred via the separating diaphragm and the fill fluid to the measuring diaphragm. When using the ceramic pressure sensor, a minimal deflection of the measuring diaphragm changes the output voltage of the pick-up system. In the silicon pressure sensor, the resistance values of four piezo-resistors doped in the measuring diaphragm will change which causes a change of the output voltage. This pressure-proportional output voltage is converted by means of the electronic matching unit and the amplifier into an electrical signal.

The measured values and the sensor parameters are transferred to the Secondary Unit, where a microprocessor computes precise primary output linearisation, compensating for the combined effects of sensor non linearity and temperature changes. In the secondary electronics EEPROM #2 stores specific transmitter information:

- non modifiable data such as the serial number, the UID (Unique Identifier), the manufacturer's name and device type, the hardware and software version of the electronics.
- the modifiable data such as the final trimming and calibration i.e., all data that can be changed by the user through the configurator devices.

... PRINCIPLE OF OPERATION

MODELS 262/264 G/A
Ranges C, F

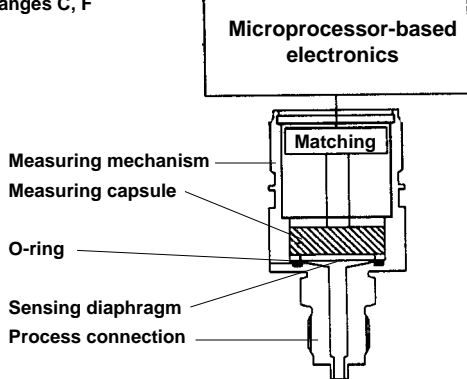

Fig. 2b - Capacitive - Ceramic pressure sensor for absolute pressure

MODELS 262/264 G/A
Ranges L, U, R, V

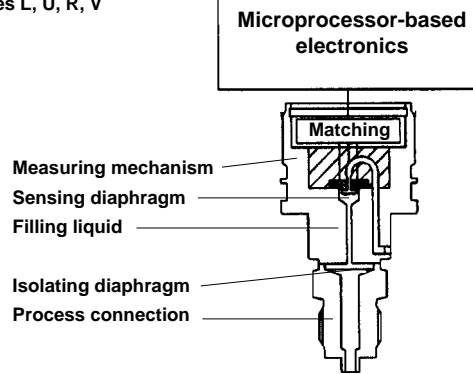

Fig. 2c - Piezoresistive - Silicon pressure sensor for gauge pressure and level

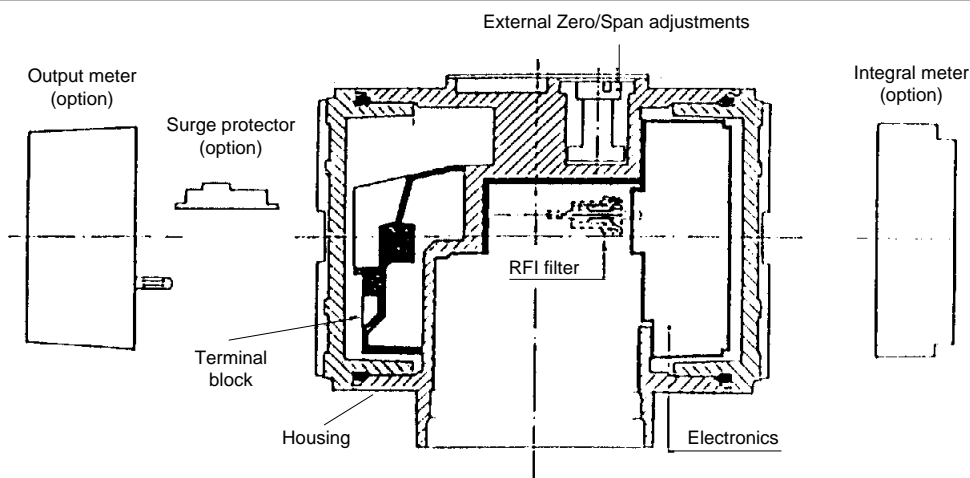

Fig. 2d - Secondary Unit

The microprocessor receives data from the internal modem, in order to provide bidirectional digital communication with the configuration device, i.e. the Hand Held terminal "Communicator" or P.C. based "Configurator".

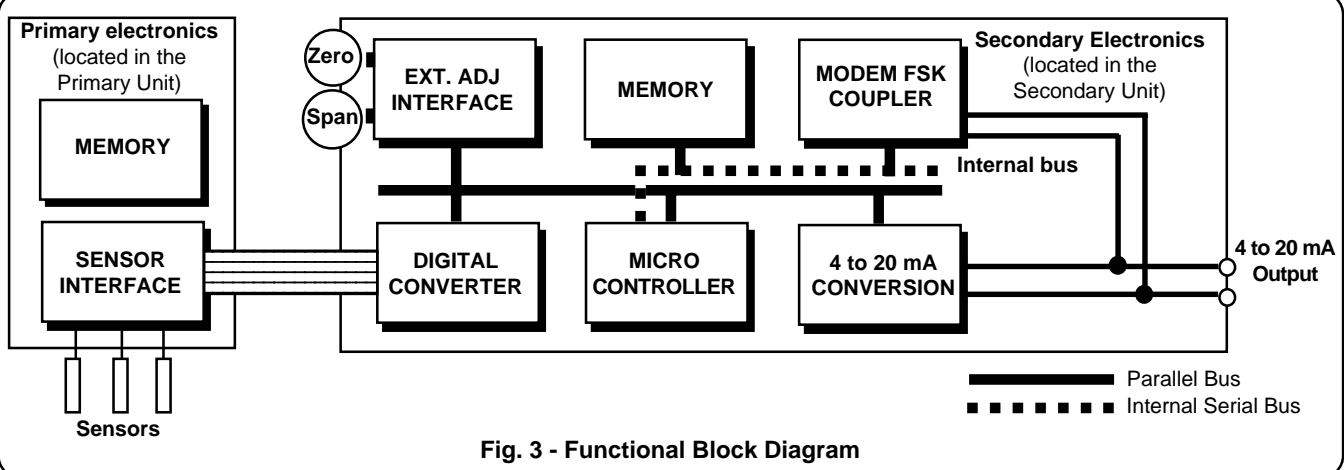

Fig. 3 - Functional Block Diagram

With secondary electronics analog+HART, it is to be considered that different communication protocols exist for configuration and maintenance operations. Here follows a brief description on the matter; please refer to appropriate technical specification for additional deeper explanations on the communication aspects.

The HART protocol is based on the standard Bell 202 FSK (Frequency Shift Keying) with a ± 0.5 mA signal modulation superimposed on the 4 to 20 mA analog signal. As the energy balance added to the current loop is virtually zero and the frequency is very high compared to that of the process dynamic,

the analog process signal remains undisturbed.

Using a configuration device it is then possible to remotely modify the configuration of the transmitter, e.g. the measuring range.

It is also possible to read other transmitter data and diagnostic information. Limited rezeroing and respanning, comparable to that of conventional analog transmitters is possible using the optional calibration device. Refer to Fig. 3 for a complete view of the Functional Block Diagram.

The sensor and all electronic parts are galvanically isolated from the transmitter body.

INSTALLATION

WARNING - In order to ensure operator safety and plant safety it is essential that installation is carried out by suitably trained personnel according to the technical data provided in the specification for the relevant model.

The transmitter may be mounted on a 2-inch pipe (fig. 4, 5a, 5b, 5c and 6) by means of the proper mounting bracket. The transmitter may also be directly, supported by the piping connection.

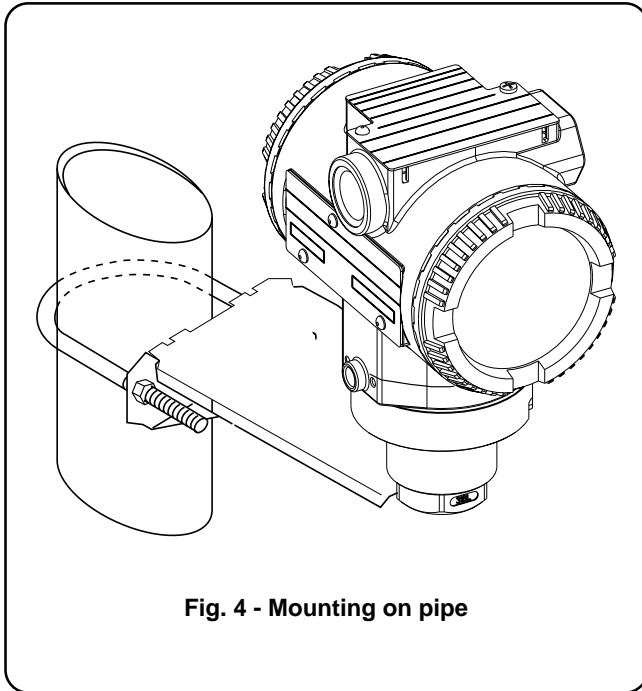

Fig. 4 - Mounting on pipe

WARNING - For installation in Hazardous Areas, i.e. areas with dangerous concentrations of e.g. gases or dusts that may explode if ignited, the installation must be carried out in accordance with relative standards either EN 60079-14 or IEC 79-14 and/or with local authority regulations, for the relevant type of protection adopted. Together with safety information here and after enclosed see also the Addendum for "Ex Safety" aspects which is part of this instruction manual.

WARNING: The transmitter when installed in accordance with this instruction manual will not be subjected to mechanical stresses.

WARNING: the transmitter should not be installed where it may be subjected to mechanical and thermal stresses or where it may be attached by existing or foreseeable aggressive substances. ABB cannot guarantee that a construction material is suited to a particular process fluid under all possible process conditions. See also the paragraph on "Operative limits".

CAUTION - Proper location of the transmitter with respect to the process pipe will depend upon the service for which the instrument is used. Care should be exercised to identify correct process connections.

The secondary unit of the transmitter may be rotated through 360° approx. with respect to the primary unit without degrading performance or damaging the internal wiring. Do not force the primary unit to rotate; use the 2 mm Allen key supplied to unlock and lock the tang grub screw (see Fig. 7). This feature, obtained by unscrewing (one turn is sufficient) the Allen screw, is particularly useful for reaching optimum access to the electrical connections and visibility of the output indicator.

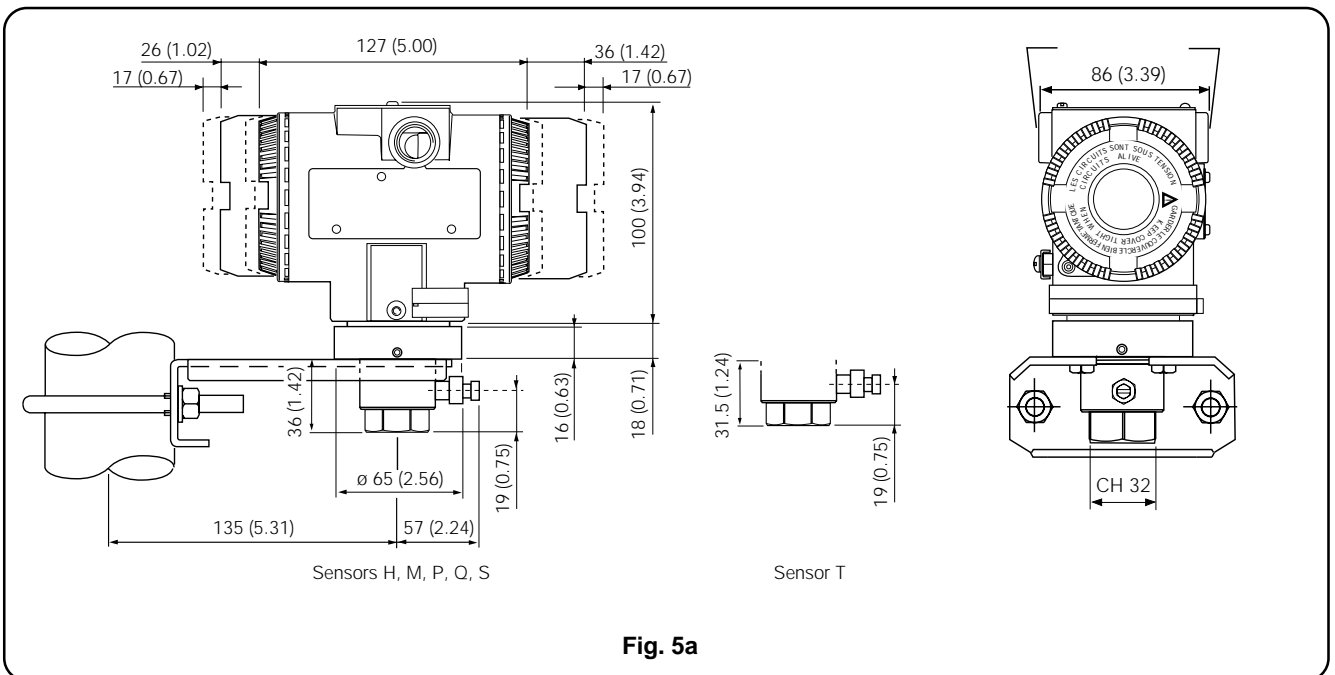
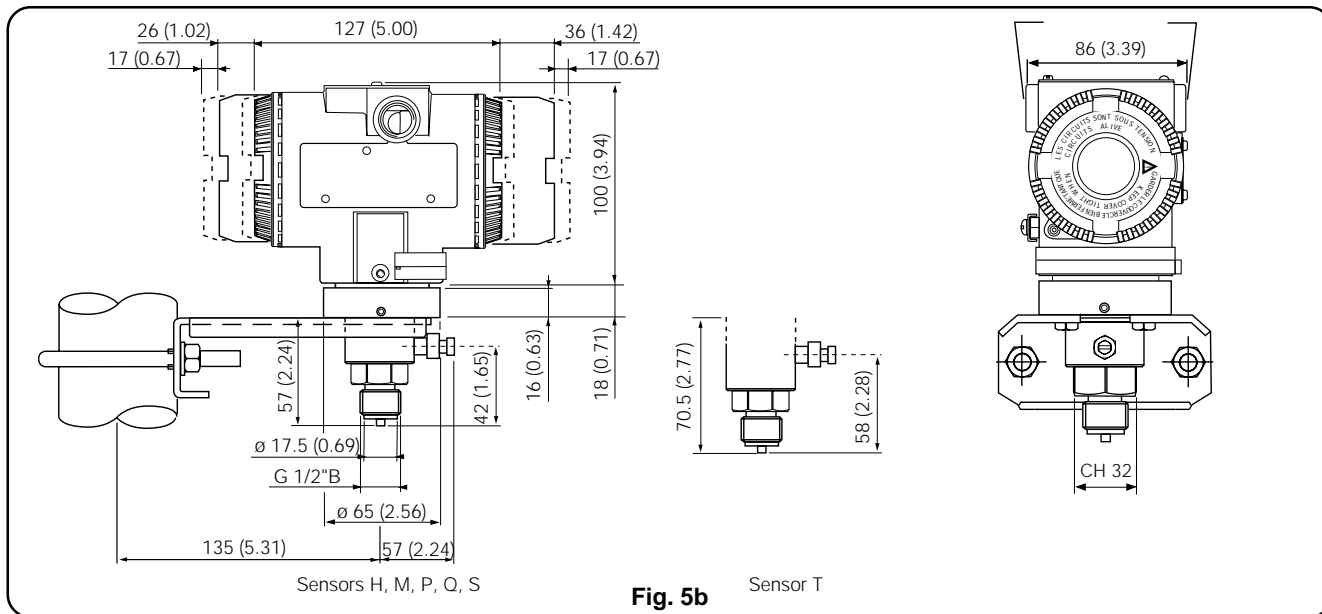

Fig. 5a

1/2in - 14 NPT female connection

... INSTALLATION



DIN-EN837-1 G 1/2in B connection

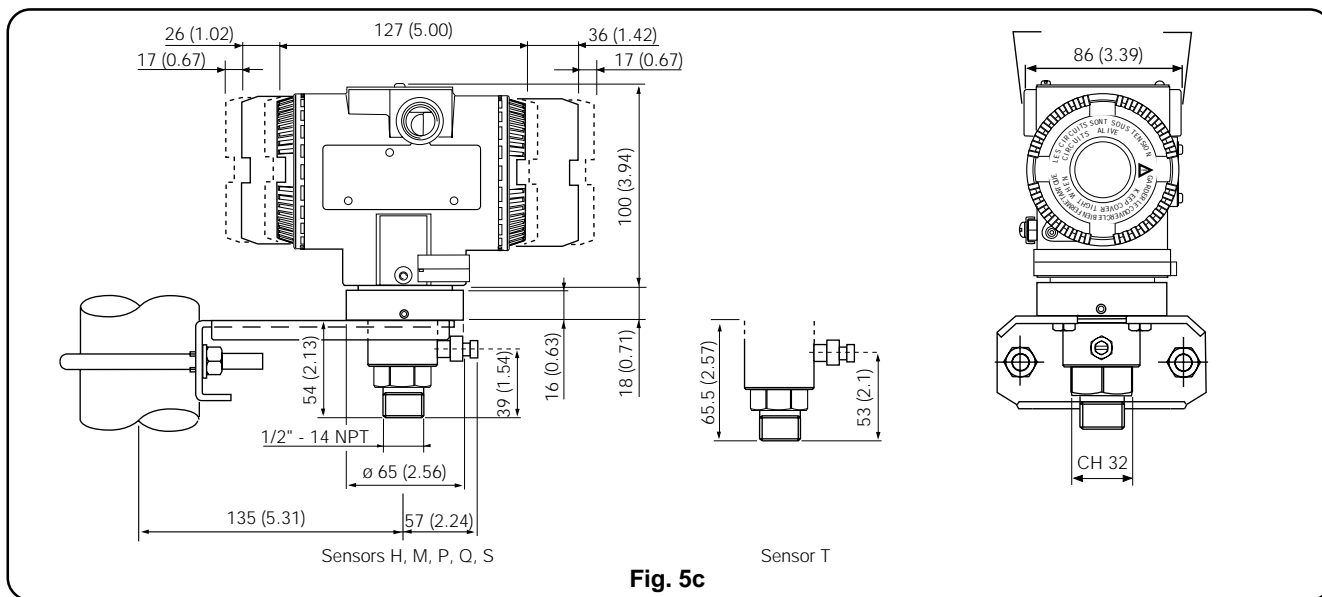

1/2in - 14 NPT male connection

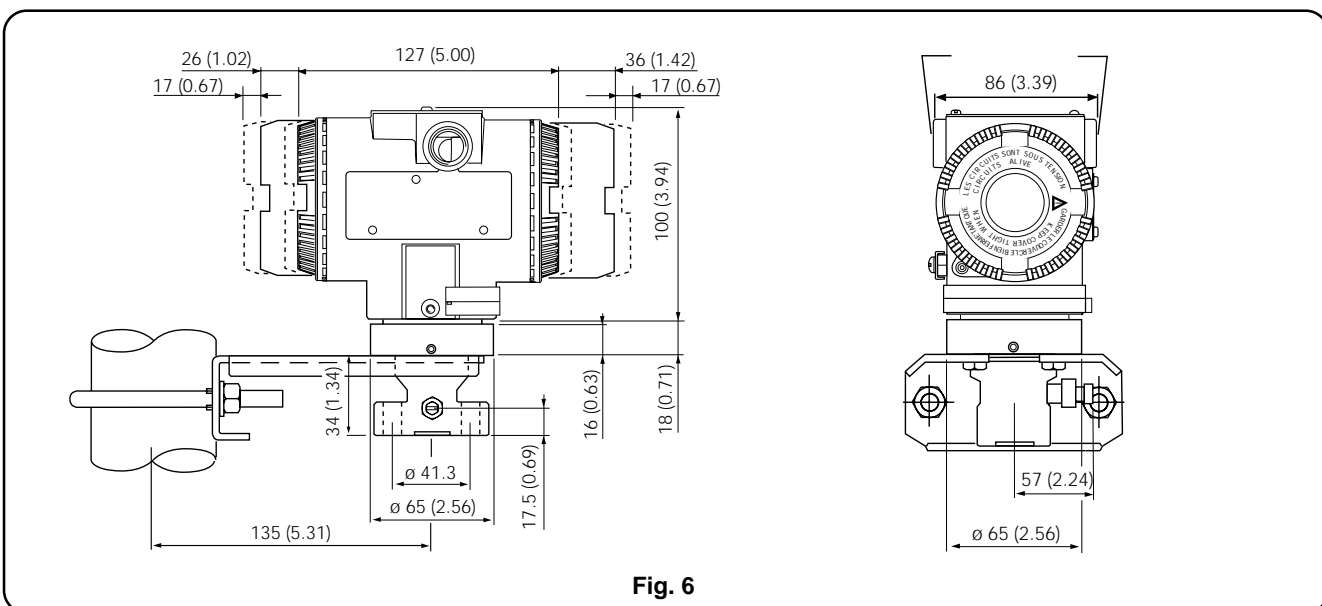

Adapter connection (7/16in 20-UNF drilling)

Note: dimensions are expressed in mm. (Between parenthesis the same dimensions expressed in inches).

ELECTRICAL CONNECTIONS

WARNING - For installation in Hazardous Areas, i.e. areas with danger of fire and/or explosion, prior to making electrical connections, ensure compliance with safety information on the Safety Marking plate. Failure to comply with this warning can result in fire or explosion.

Signal terminals are located in a separate compartment of the secondary unit housing. The housing incorporates two connection ports for cable glands or conduit fittings. They are protected with a temporary plastic plug for transit purpose which should be replaced with a suitable permanent plug in the unused port. Connections can be made by removing the cover (indicated in Fig. 7); first screw down the locking screw located below the cover, using a 3 mm Allen Key.

WARNING - For Hazardous Areas installations, the connection of cables and conduits to the transmitter shall be made in accordance with the requirements of the relevant type of protection. Cables and cable-glands must be in accordance with the type of protection. Unused openings for connection shall be closed with blanking elements suitable for the relevant type of protection. With the exception of intrinsically safe transmitters, the means provided for this shall be such that the blanking element can be removed only with the aid of tools. The blanking elements must be certified for the type of protection. See standards either EN 60079-14 or IEC 79-14. The transmitter connections must also guarantee the degree of protection of the transmitter enclosure, e.g. IPxx according to EN 60529 standard (or IEC529). See also the Addendum for "IP" protection (and Ex Safety) which is part of this instruction manual.

The signal cable should be connected to the terminals marked respectively (+) and (-). If an internal output meter - either with analog or digital indication - is installed, it should be removed in order to make the connection, simply by pulling it out from its socket. After the connections have been made, reinstall the output meter. Refer to the **Meters Option** addendum for details.

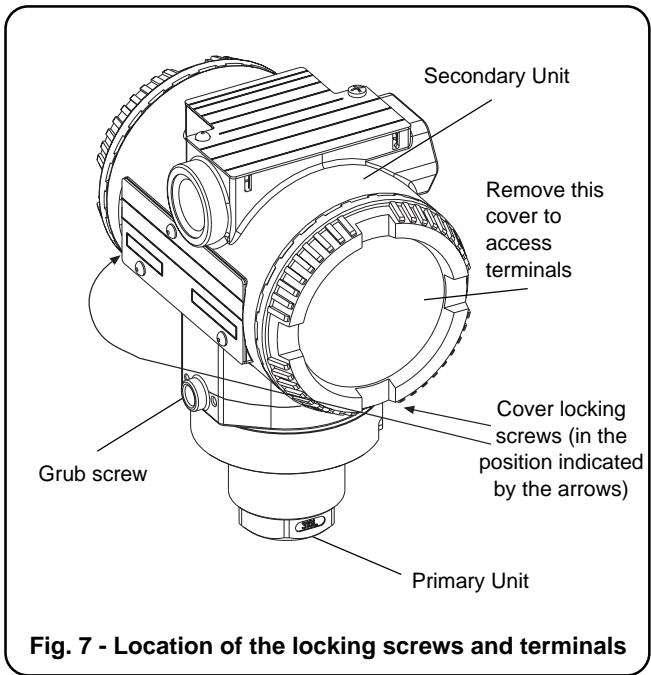

The power to the transmitter is supplied over the signal wiring and no additional wiring is required. The signal wiring does not need to be shielded but the use of a twisted pair is highly recommended. The cable shield should be grounded in one side only, to avoid dangerous earth paths.

WARNING - For Hazardous Areas installations, when the ambient temperature is higher than 70°C, the cable used for the connections must be suitable for 5°C above the ambient temperature.

Normal practice is to ground in the control room side, in which case the field side of the screen should be adequately protected to avoid contact with metallic objects. Signal wiring may be ungrounded (floating) or grounded at any place in the signal loop, but for intrinsically safe installations the wiring and grounding must follow the specific rules for this technique. The transmitter case may be grounded or ungrounded: a ground connection is provided internally (in the terminal compartment) and externally.

Do not run the signal wiring in close proximity to power cable or high power equipment; use dedicated conduits or trays for signal wiring.

CAUTION - Do not connect the powered signal wiring to the mA signal testing terminals as this could damage the by-pass diode.

After the connections have been completed check the integrity of the cover O-ring, screw down the cover and secure it by unscrewing the safety screw.

CAUTION - Unless absolutely necessary, avoid the removal on site of the protective cover which gives access to the electronic circuitry. Although the electronics are fully tropicalized they should not be subjected to humidity for long periods.

WARNING - For Hazardous Areas installations, at least eight (8) threads on each cover must be engaged in order for the transmitter to meet (flameproof - explosion-proof) requirements.

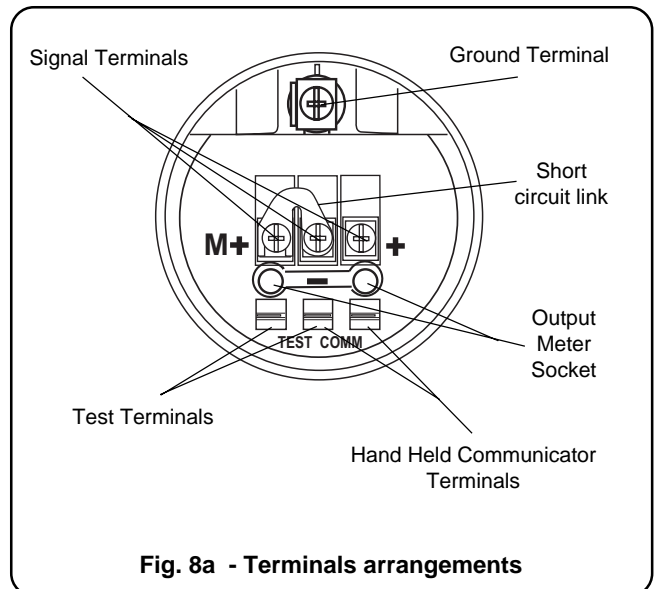

... ELECTRICAL CONNECTIONS

WARNING : DO NOT ATTEMPT TO CONNECT AN AMPEROMETRIC BETWEEN A "TEST" TERMINAL AND A "COMM" TERMINAL. THE RESULT TO THE POWER SUPPLY IS A SHORT WHICH WILL BLOW FUSES AND POSSIBLY DAMAGE YOUR EQUIPMENT, ALSO CAUSING TO INTERRUPT FUNCTION OF OTHER DEVICES POWERED FROM SAME SUPPLY.

NOTE : If the use of the Hand Held Communicator is foreseen, a resistance of 250 ohms minimum **must** be included in the current loop, between the power supply and the connection point of the Hand Held Terminal, for communication purpose.

Here below is given an explanation regarding the possible connection of the terminal block to the power supply and a representation of the connection in case of remote indicator presence.

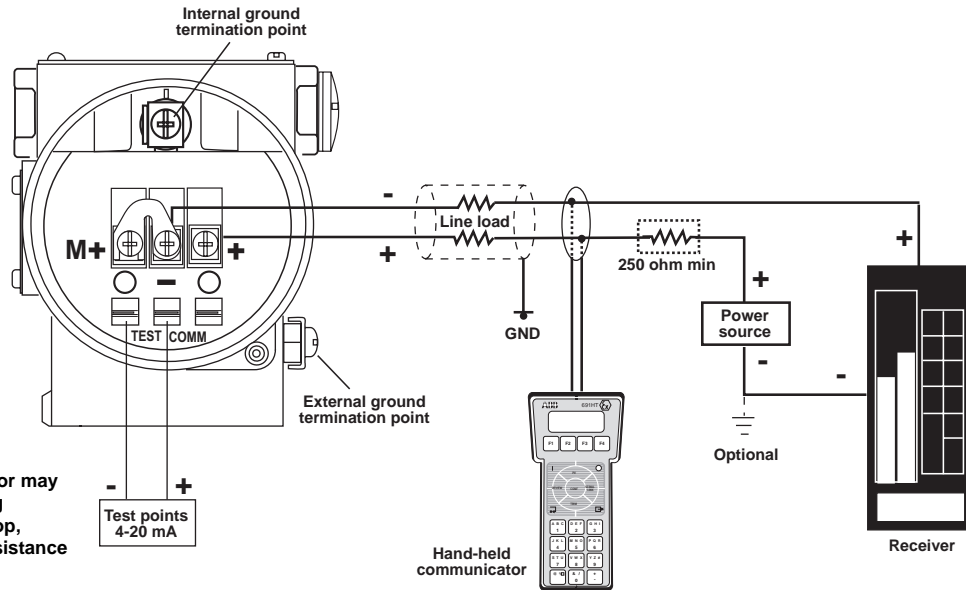

Fig. 8b - Electrical connections

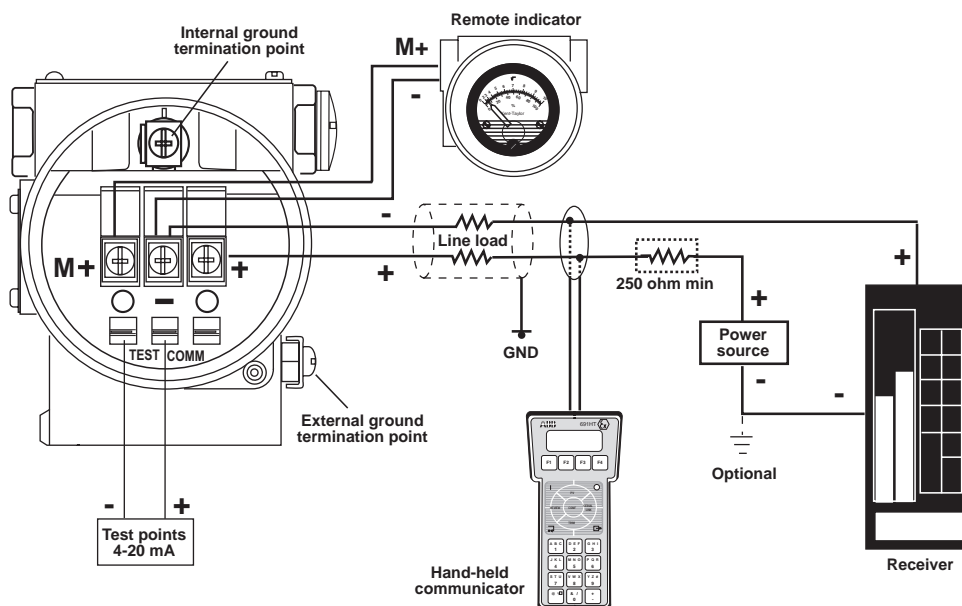

Fig. 8c - Electrical connections with remote indicator

ELECTRICAL REQUIREMENTS

The transmitter operates on a minimum voltage of 10.5 Vdc to a maximum of 55 Vdc and is protected against polarity inversion.



Note - The transmitter operates from 10.5 to 42 Vdc with no load (a load up to 620 Ω allows operation up to 55 Vdc). For EEx ia and intrinsically safe (FM, CSA and SAA) approval power supply must not exceed 30 Vdc. In some countries the maximum power supply voltage is limited to a lower value.

Installing optional devices the minimum voltage increases to:

- 10.5 Vdc with no option or with integral digital display
- 10.7 Vdc with output analog indicator
- 12.5 Vdc with output LCD indicator
- 12.1 Vdc with surge protection
- 14.1 Vdc with LCD indicator and surge protection
- 13.1 Vdc with LCD CoMeter
- 14.3 Vdc with no link on output indicator plug

The total loop resistance is indicated in the figure and expression below.

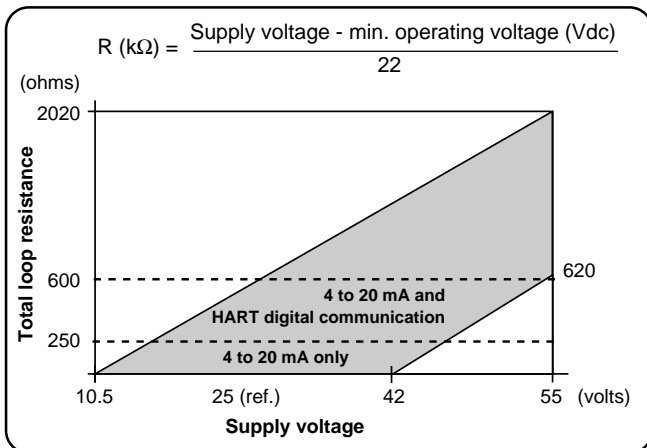

The total loop resistance is the sum of the resistance of all elements of the loop, including wiring, conditioning resistor, safety barriers and additional indicators (excluding the equivalent resistance of the transmitter).

Where a configuration device (HART), such as the Hand Held Communicator or a Modem is likely to be used, a resistance of 250 ohm minimum should be present between the power supply and the point of insertion of these devices, to allow communication.

Several types of safety barriers, either passive or active, can be satisfactorily used in conjunction with the Smart 2600T transmitter. Nevertheless, in case of use of active barriers, check with the supplier if the model is suitable for use with smart transmitters allowing the connection of the configuration devices in the "safe" or non-hazardous area.



WARNING - The transmitter may be used as a safety accessory (as defined by the Pressure Equipment Directive 97/23/EC) i.e. as part of a shutdown system. In this case it is recommended to select the correct fail safe mode for the 4-20 mA signal (as per Namur NE43 recommendation). See also the instructions relevant to fail safe selection (Up/Down scale mode) in the addendum to the instruction manual on "Use of hardware links on the secondary electronics".

RANGE AND SPAN CONSIDERATION

The Smart 2600T Transmitter Specification Sheets provide all information concerning the Range and Span limits in relation to the model and the sensor code.

The terminology currently used to define the various parameters is as follows:

URL : Upper Range Limit of a specific sensor. The highest value of the measured value that the transmitter can be adjusted to measure.

LRL : Lower Range Limit of a specific sensor. The lowest value of the measured value that the transmitter can be adjusted to measure.

URV : Upper Range Value. The highest value of the measured value to which the transmitter is calibrated.

LRV : Lower Range Value. The lowest value of the measured value to which the transmitter is calibrated.

SPAN : The algebraic difference between the Upper and Lower Range Values. The minimum span is the minimum value that can be used without degradation of the specified performance.

TURN DOWN RATIO : is the ratio between the maximum span and the calibrated span.

The transmitter can be calibrated with any range between the LRL and the URL with the following limitations:

$$\begin{aligned} \text{LRL} &\leq \text{LRV} \leq (\text{URL} - \text{CAL SPAN}) \\ \text{CAL SPAN} &\geq \text{MIN SPAN} \\ \text{URV} &\leq \text{URL} \end{aligned}$$

CALIBRATION

Unlike conventional electronic transmitters, the use of a microprocessor and the presence of serial communications between the transmitter and the configuration device, allows the use of several different approaches in calibration and servicing. Different methods can be used to calibrate the Smart transmitter:

- i) using the local keys in the transmitter secondary unit.
- ii) using zero/span raise/lower on transmitter electronics links.
- iii) using the Hand Held Communicator.
- iv) using the Personal Computer Configuration Software Package.

This chapter describes the first method; the others are described next or in the relevant Instruction Manuals of configuration tools.

In the addendum (use of hardware links on the secondary electronics) there is an explanation of the raise/lower operation for ZERO and SPAN. In the Analog + HART version it is also possible to apply a scaling to the reading of the transmitter. The operation is called PV-scaling and is used to align the "zero" of the process with the "zero" reading of the transmitter. See the description in the Addendum for PV scaling operation.

Note: Unless otherwise specified the instrument is factory calibrated at maximum span with the LRV set to true zero. Instruments adjusted and tagged for a specific range will not require recalibration. **Rezeroing of the transmitter may be required in order to compensate for zero shift arising from the installation.**

Preliminary operation

Before commencing calibration ensure that:

- i) the required span, the upper and lower range value (URV & LRV) are within the span and range limits (URL & LRL) indicated on the nameplate (please refer to "Range and Span" consideration on the previous page).
- ii) the transmitter is properly powered and the electrical connections correctly made.
- iii) the write protect link, located on the electronics module is in position OFF (write allowed). Access to the link is gained by unscrewing the secondary unit housing cover at the opposite end to the terminal cover (See Fig. 9).
- iv) the Upscale/Downscale link is positioned to the required function: ON for Downscale OFF for Upscale (see Fig. 9).
- v) make the electrical connections, as indicated in Fig. 10. Connect a precision milliammeter as shown and **remove the short circuit link.**

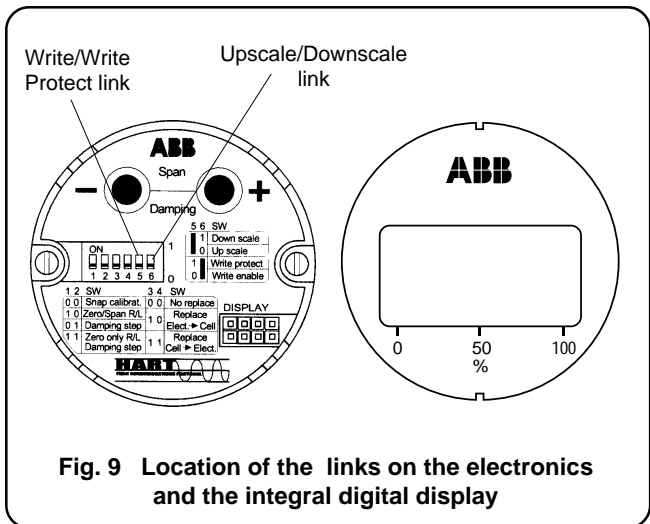

Fig. 9 Location of the links on the electronics and the integral digital display

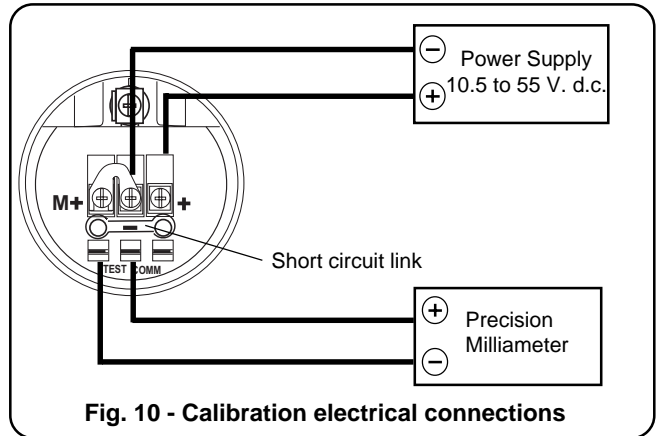

Fig. 10 - Calibration electrical connections

Set up an appropriate test rig in accordance with the required calibration. Figure 11 shows a complete test rig that can be selectively used to suit the calibration.

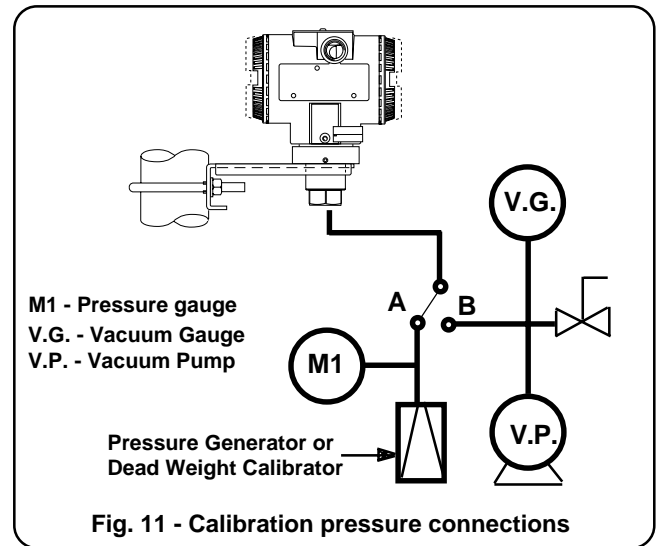

Fig. 11 - Calibration pressure connections

Note that calibration accuracy is strictly related to the accuracy of the test equipment: the use of a dead weight tester is highly recommended.

The local adjustment keys are located behind the Nameplate. To gain access slacken the nameplate screw and rotate 90°; proceed in the reverse mode when the calibration procedure has been completed. Fig. 12 shows the calibration screws: they provide two large plastic heads that can rotate 90° in the direction indicated by the arrows, with spring-return to normal. The calibration screws can be removed after the calibration, to avoid improper use by inserting a screwdriver blade below the plastic flange and pulling out.

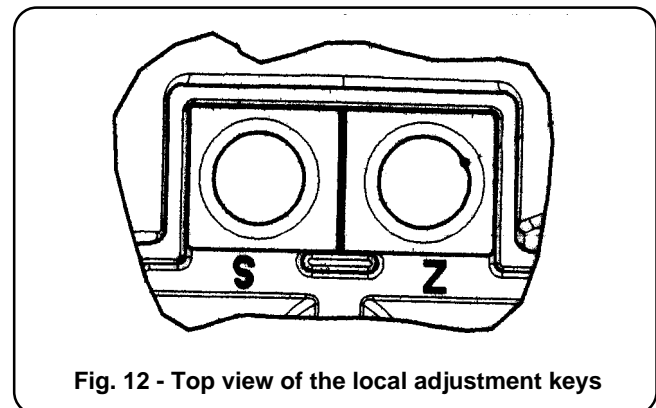

Fig. 12 - Top view of the local adjustment keys

.... CALIBRATION

Zero and span - true zero procedure

Gauge pressure

- Set the A-B switch into "A" position
- Switch on the power supply.
- With no pressure applied to the transmitters, the value read on the digital milliammeter should be 4 mA ; if it is not press the zero screw for at least 1 second. After this operation the reading should move to 4 mA; if no change occurs repeat the operation.
- Apply a pressure equal to the upper range value (URV) and allow time for the pressure to stabilize.
- Press the span screw for at least 1 second: after this operation the reading on digital milliammeter should be 20 mA and the calibration procedure is complete. If no change occurs either the calibration procedure was not correctly performed or the span exceeds the limit; correct and repeat the operation.

Absolute pressure

- Set the A-B switch into "B" position
- Switch on the power supply.
- Operate the vacuum pump connected to the transmitter and draw the maximum possible vacuum obtainable. The value read on the digital milliammeter should be 4 mA ; if it is not press the zero screw for at least 1 second. After this operation the reading should move to 4 mA; if no change occurs repeat the operation.
- If the value of the calibration span (URV) is less than atmospheric pressure gently open the vent valve so increasing the pressure to the Upper Range Value. If the calibration span (URV) is greater than the atmospheric pressure then set the A-B switch to "A" position and generate a pressure corresponding to the URV. Allow time for the pressure to stabilize.
- Press the span screw for at least 1 second: after this operation the reading on digital milliammeter should be 20 mA and the calibration procedure is complete. If no change occurs the calibration procedure was not correctly performed or the span exceeds the limit; correct and repeat the operation.

Zero suppression procedure

Gauge pressure

Two different methods (a) or (b) can be used :

- After completion of the zero and span procedure above, apply a pressure equal to the pressure to be suppressed. Allow time for pressure stabilization and then press the zero screw for at least 1 second. After this operation the digital milliammeter reading should be 4mA and the Upper Range Value automatically moved to a value equal to the sum of the pressure to be suppressed and the previous calibrated span.
- Use the zero and span procedure above but apply pressures equal to the Lower Range Value (LRV) and then to Upper Range Value (URV), and pressing, for at least 1 second, the zero and span screws respectively.

Absolute pressure

Use the zero and span procedure above but apply to the process connection absolute pressures equal to the Lower Range Value (LRV) and then to the Upper Range Value (URV), pressing, for at least 1 second, the zero and span screws respectively.

Zero elevation procedure

This procedure applies to the gauge pressure transmitter, only. The zero can be elevated up to a full vacuum. Apply pressures equal to the LRV (this value is therefore between the zero gauge pressure and the full vacuum) and then equal to the upper range value (URV) and correspondingly press the zero and span screws respectively.



NOTE - To prevent unauthorized calibration operation refit the write protection link in position P (Write Protect).



Note - If during the calibration procedure the readings on the digital milliammeter are outside its inherent accuracy, output trimming of the transmitter may be requested. This operation can only be performed using the Hand Held Terminal Communicator or the Personal Computer Configurator. If this equipment is not available the transmitter should be returned to a Service Center for recalibration.

In some cases, especially for tank level measurement, the calibration can also be obtained automatically by the indication of the actual output percentage, without any calculation for LRV and URV. The operation is called Output % Reranging and can be performed using a HART configuration tool (see the ADDENDUM on Output % Reranging).

DISMANTLING AND REASSEMBLY



WARNING - Process fluids and/or pressure retained in the transmitter primary unit can cause severe injury and death or damage to the equipment. It is the user responsibility to make sure that the instrument is not under pressure before removing the instrument from service or when draining or venting.

Dangerous fluids

In case of toxic or otherwise dangerous process fluid, take any precautions as recommended in the relevant Material Safety Data Sheet.



CAUTION - Dismantling and reassembly should not be carried out on site because of the risk of damage to components and printed circuits as a result of adverse environmental conditions such as humidity, dust, etc. The dismantling and reassembly procedures given below should be carried out in the listed order to avoid instrument damage.

Required tools

2 mm Allen key
3 mm Allen key
Small Phillips screwdriver
Small flat-bladed screwdriver
13 mm spanner
13 mm torque wrench - (Range > 17 Nm - 12.6 foot lbs)

Dismantling

- a) Screw down completely the cover locking screw, electronics side, using the 3 mm Allen key
- b) Unscrew and remove the covers
- c) Unscrew the two fixing screws and remove the secondary electronic assembly
- d) Unplug the sensor cable
- e) Remove the tang grub screw using the 2 mm Allen key
- f) Unscrew the housing taking care not to damage the sensor cable or the connector.

Reassembly



WARNING - Assembling the components with improper "O rings" can cause fracture or overstressing and release of pressurized process material. Use only official spare parts (*) and do not exceed the specified torque limits. **DO NOT REMOVE** the "O ring" fitted in the sensor neck: it provides the housing a degree of protection.

- a) Insert the sensor cable in its recess at the bottom of the housing.
- b) Screw the housing down completely until the nesting of housing/sensor assy is reached, then unscrew by one complete turn maximum. Rotate the topwork in the desired position and lock it with the tang grub screw previously removed.
- c) Plug the sensor cable to the secondary electronics. Fix the electronic circuit by its screws.
- d) Refit the covers and tighten securely.



WARNING - For Hazardous Areas installations, at least eight (8) threads on the cover must be engaged in order to meet the (flameproof - explosion-proof) requirements.

- e) Unscrew the cover locking screw to secure the covers. This is **mandatory** to meet "**Flameproof requirements**" for **Hazardous Areas installation**.



PRESSURE TEST WARNING

Once reassembled the process flanges and the transducer, a pressure test is required. At this purpose, apply a hydrostatic pressure of the maximum overrange pressure rating to both process connections simultaneously. Wait for one minute, then verify that no leakages occurred. Repeat the assembly procedure and the pressure test.

(*) The spare parts list is available at:
<http://138.221.224.36> or from local ABB representatives.

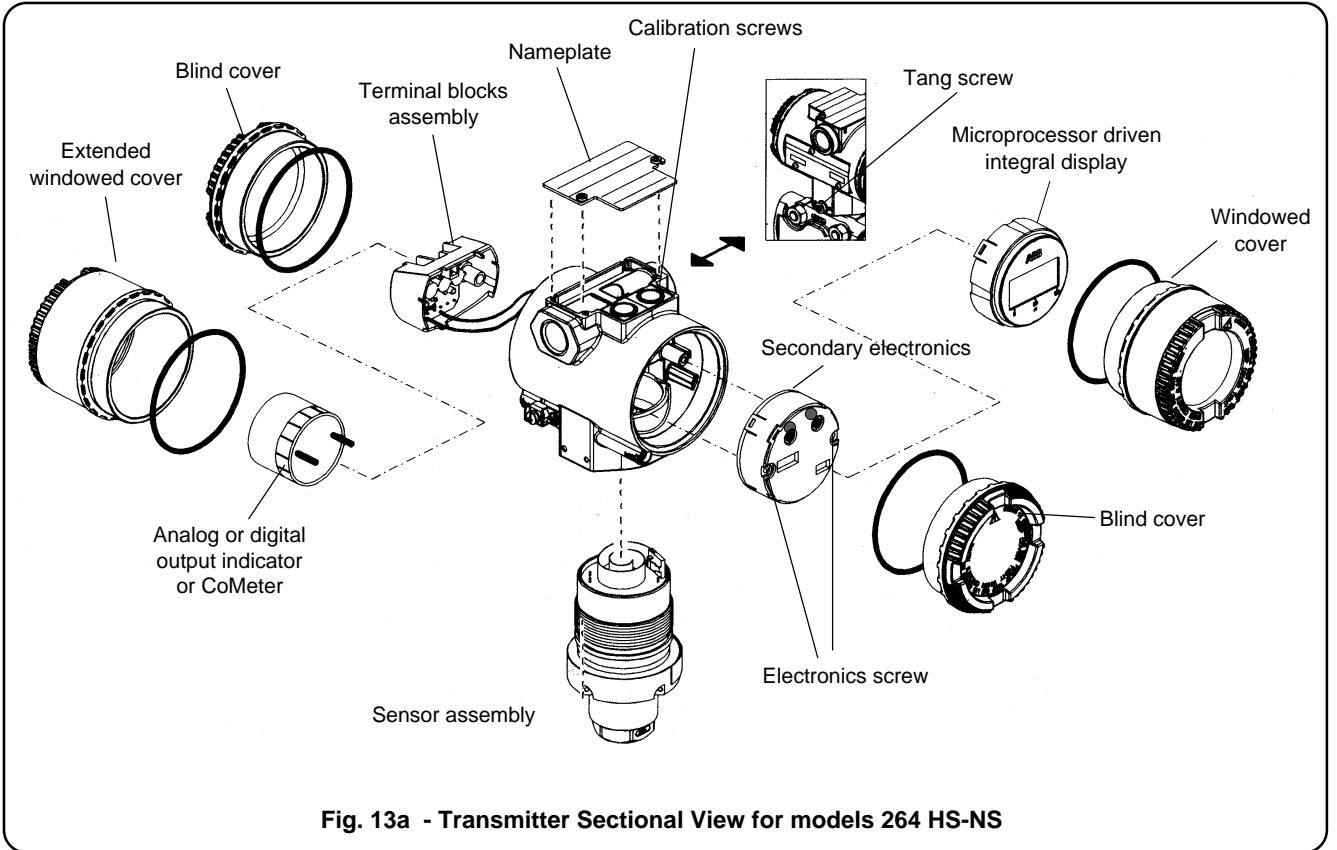

Fig. 13a - Transmitter Sectional View for models 264 HS-NS

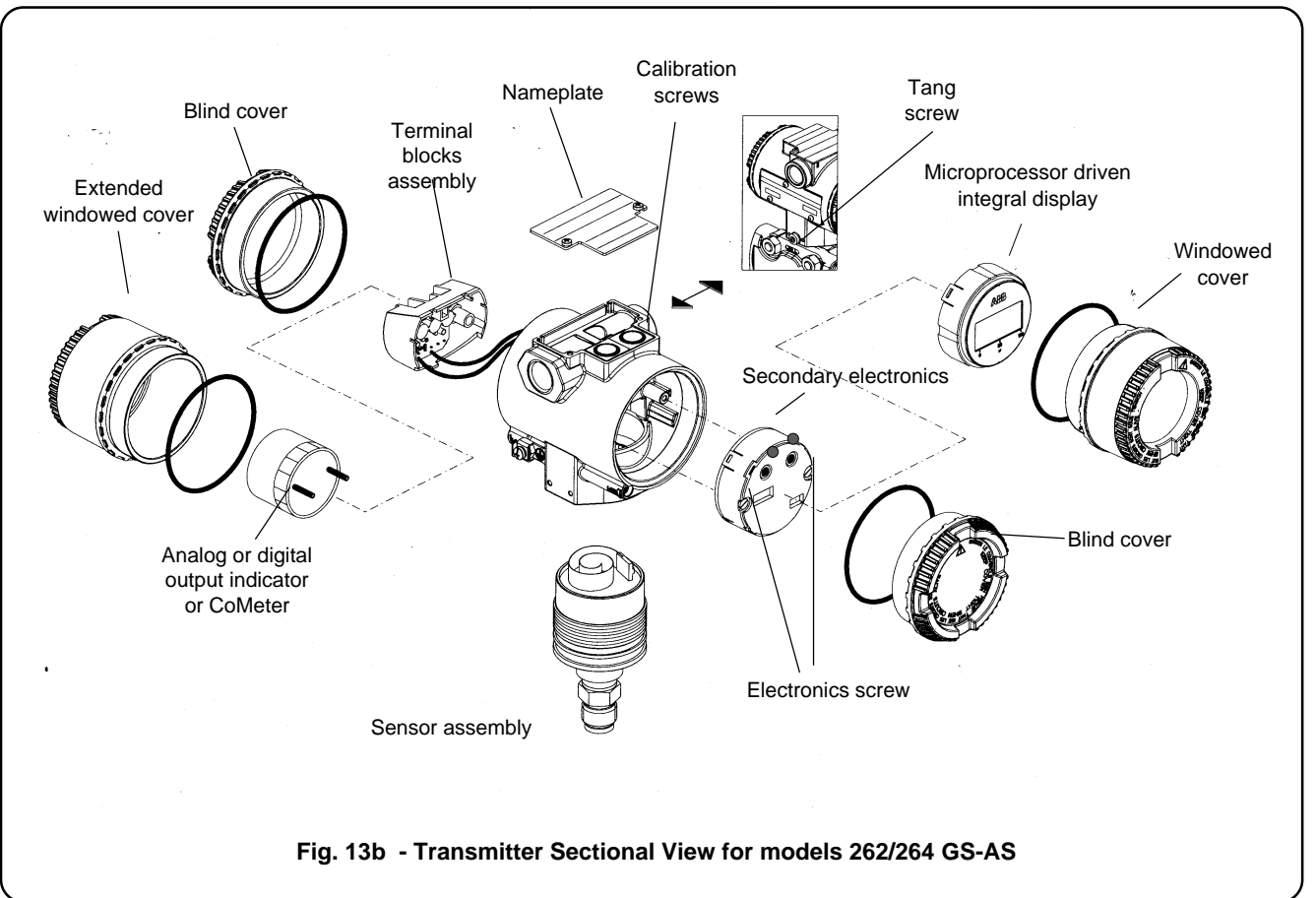

Fig. 13b - Transmitter Sectional View for models 262/264 GS-AS

SIMPLE FAULT FINDING (HART)

This part is applicable only for a quick fault finding in the case that the Hand Held Terminal or the P.C. Configurator Package are not available.

If the transmitter does not appear to be working satisfactory, carry out the following fault finding checks before contacting your nearest Service Centre.

If the instrument is to be returned for repair, ensure that it is adequately packed using the original polystyrene box or high density chip foam: **the trouble sheet/returning form should be sent with the instrument, filled in all its parts.** If the transmitter needs to be dismantled follow the procedures of the previous section.

WARNING : If the transmitter forms part of a control loop, the plant must be placed under local manual control while the instrument is examined or taken out of service. Take all precautions to avoid damages caused by pressure or dangerous fluids release.

Equipment needed

Voltmeter , milliammeter (0 to 100 mA d.c.), solvent contact cleaner.

High, Low or Irregular Output

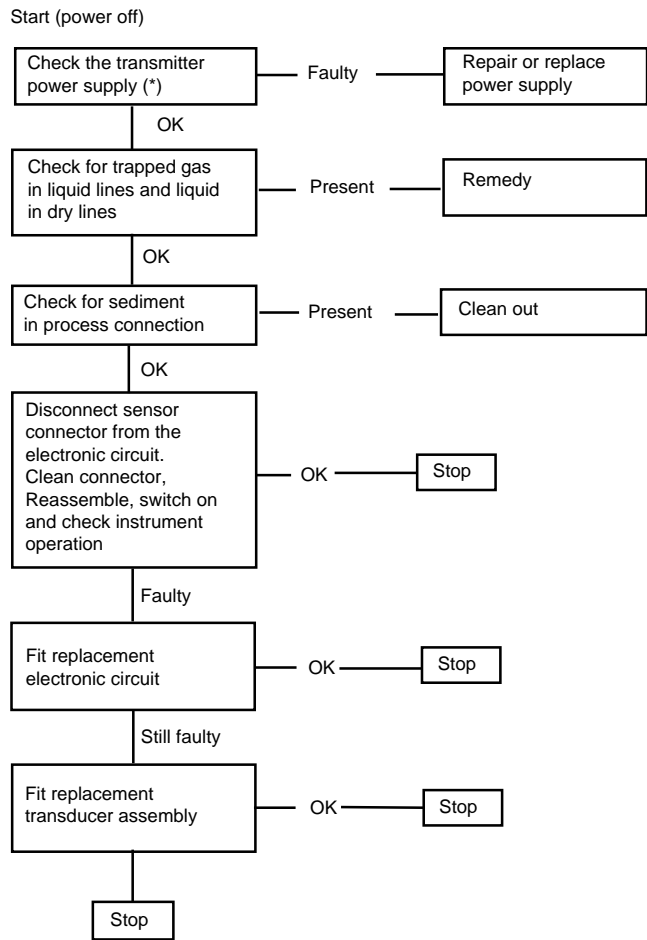

No output

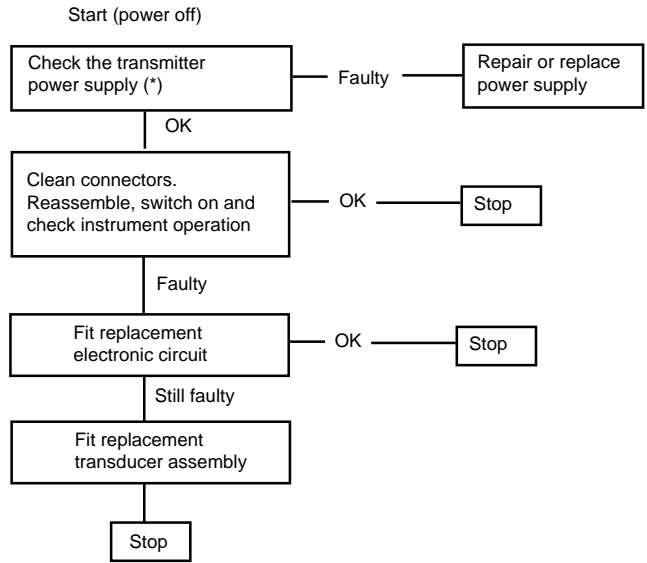

WARNING - If the transmitter needs to be repaired, the faulty unit/assembly must be replaced by an equivalent unit/assembly.

(*) If the source of the problem is suspected to be the power supply, check it by disconnecting the wires from the transmitter and testing the volts available at the wires.



TROUBLE SHEET

WARRANTY REPAIR REPAIR ORDER

Rejection or discrepancy reports

Copy attached Not available

● IDENTIFICATION

Customer

Purchase order No.

Plant

Name of person to contact

Instrument tag No.

Model

Serial No.

● OPERATING CONDITIONS

Specify location, environmental conditions, type of service and approximate number of operating hours or date of installation if known.

[Empty text box for operating conditions]

● REASON FOR RETURN

[Empty text box for reason for return]

Trouble found during : Installation Commissioning Maintenance

At start up On service

Shipping information for the return of the equipment

Material returned for factory repair, should be sent to the nearest ABB Service Center, transportation charges prepaid by the Purchaser.

Please enclose this sheet duly completed to cover letter and packing list

Date

Signature

Originator

ADDENDUM FOR "METERS" OPTION OF THE TRANSMITTERS

GENERAL DESCRIPTION

This option provides four different indications (meters) inside the transmitter housing. Three meters, "output meters", can be mounted on the terminal block (field terminals) side; the first is of "analog" type, the second is of "digital" type (LCD, 3 1/2 -digit) and the third is the CoMeter. All are operated by the output signal of the transmitter. The fourth meter, "integral digital display", is mounted on the electronics side: it is of "digital" type (LCD, 4-digit), microprocessor driven. The integral digital display has 4 different mounting positions. The analog meters can be rotated to exactly match the mounting position of the transmitter (see Figs. 1, 2, 3 and 5).

ANALOG OUTPUT METER

The analog output meter provides a 90° scale indication. It has either a 0 to 100 linear scale or a 0 to 10 square root scale.

ANALOG OUTPUT METER CALIBRATION

The calibration of the analog type meter only involves zeroing. Fig. 1 shows the analog output meter and the location of the zero adjustment.

The calibration is quite simple using one of the following methods:

- with the loop unpowered adjust the zero screw to read exactly the **true zero** mark on the scale (Fig. 1).
- with the transmitter transmitting 4 mA adjust the zero screw to read exactly the **live zero** of the scale.

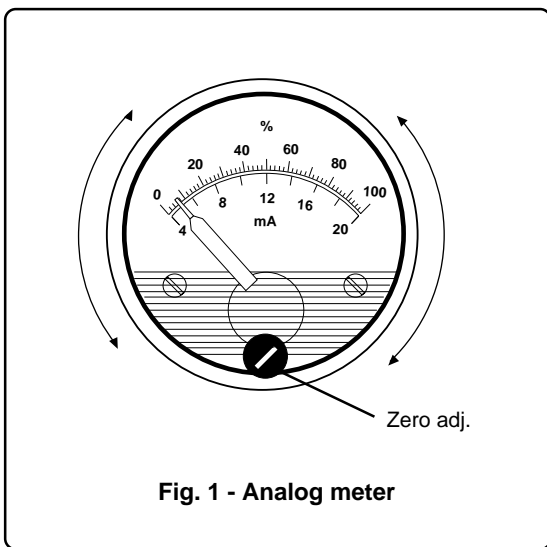

Fig. 1 - Analog meter

DIGITAL OUTPUT METER

The digital output meter has a 3 1/2-digit, 10 mm (3/8 in) high liquid crystal display (LCD). The maximum count is 1999.

DIGITAL OUTPUT METER CALIBRATION

The LCD digital type output meter can be calibrated, to indicate the output current, output as a percentage or the process value. Meter calibration may be accomplished during calibration of the transmitter or utilizing the capability of the Smart transmitter as a current generator. However the latter can be used only in conjunction with the Hand Held Communicator or a suitable P.C. based program.

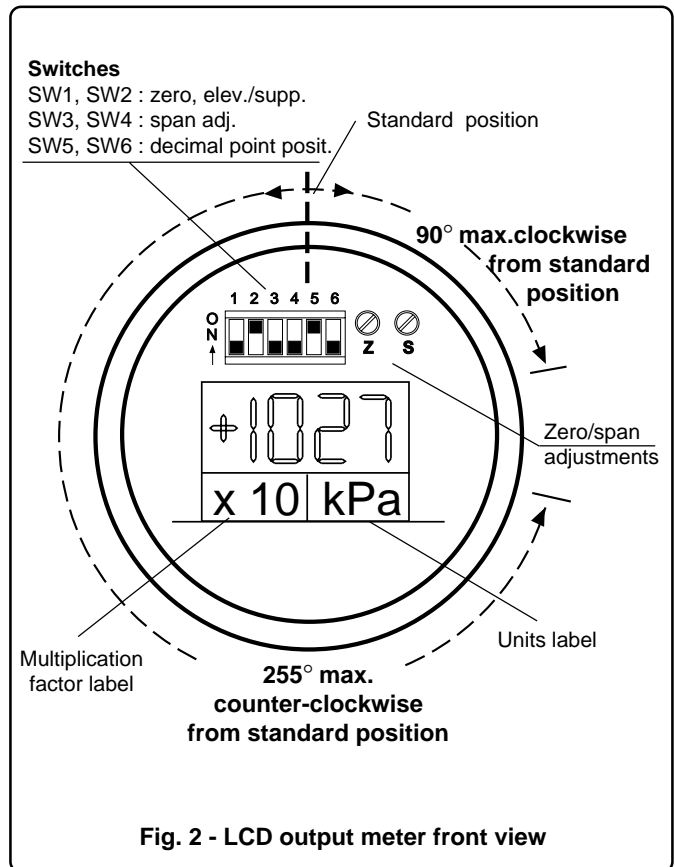

Fig. 2 - LCD output meter front view

... ADDENDUM FOR "METERS" OPTION OF THE TRANSMITTERS

The calibration can be performed in output current or percentage, or in process engineering units (see fig. 2).

Proceed as follows:

A) OUTPUT CURRENT (4÷20 mA)

- 1) The switches from SW1 to SW6 must be positioned as follows :
ON - OFF - ON - OFF - ON - OFF
- 2) Set the output current of the current generator to 4 mA, reading it on the milliammeter or 1 V. on the DVM. Alternatively force, using the "Loop Test" procedure on the Hand Held Communicator, the output of your Smart transmitter to 4 mA.
- 3) Adjust the zero trimmer (Z) to read approximately 4.00
- 4) Set the output current to 19.9 mA, reading it on the milliammeter, or 4.975 V. on the DVM. Alternatively force the output of your Smart transmitter to 19.9 mA checking for this value in the Hand Held Communicator.
- 5) Adjust the span trimmer (S) to read approximately 19.90.
- 6) Repeat the points 2) 3) to read exactly 4.00 (± 0.1)
- 7) Repeat the points 4) 5) to read exactly 19.90 (± 0.1)
- 8) Fit the "mA" unit label in the right recess below the indication.

B) OUTPUT PERCENTAGE (0÷100%)

- 1) The switches from SW1 to SW6 must be positioned as follows :
ON - OFF - ON - ON - OFF - ON
- 2) Set the output current of the current generator to 4 mA, reading it on the milliammeter or 1 V. on the DVM. Alternatively force, using the "Loop Test" procedure on the Hand Held Communicator, the output of your Smart transmitter to 4 mA.
- 3) Adjust the zero trimmer (Z) to read approximately 00.0
- 4) Set the output current to 20 mA, reading it on the milliammeter, or 5 V. on the DVM. Alternatively force the output of your Smart transmitter to 20 mA checking for this value in the Hand Held Communicator.
- 5) Adjust the span trimmer (S) to read approximately 100.0.
- 6) Repeat the points 2) 3) to read exactly 00.0 (± 0.1)
- 7) Repeat the points 4) 5) to read exactly 100.0 (± 0.1)
- 8) Fit the "%" unit label in the right recess below the indication.

C) ENGINEERING UNITS

The switches must be positioned as follows:

SW1 SW2 For ZERO adjustment, between

OFF	OFF	-1999 ÷ -1000
OFF	ON	-1000 ÷ 0
ON	OFF	0 ÷ 1000
ON	ON	1000 ÷ 1999

SW3 SW4 For SPAN adjustment, between

ON	ON	100 ÷ 1000
ON	OFF	1000 ÷ 2000
OFF	ON	2000 ÷ 3000
OFF	OFF	3000 ÷ 3998

SW5 SW6 For DECIMAL POINT position, like

ON	OFF	4.00 ÷ 19.99
OFF	ON	40.0 ÷ 199.9
OFF	OFF	400 ÷ 1999

Then proceed as follows:

- 1) Set the output current of the current generator to 4 mA on the milliammeter or 1 V. on the DVM. Alternatively, using the "Loop Test" procedure on the Hand Held Communicator, force the output of your Smart transmitter to 4 mA.
- 2) Adjust the zero trimmer (Z) to read approximately the lower range value (LRV) on the digital meter.
- 3) Set the output current to 20 mA, on the milliammeter or 5 V. on the DVM. Alternatively force the output of the transmitter to 20 mA using the Hand Held Communicator.
- 4) Adjust the span trimmer (S) to read approximately the upper range value (URV) on the digital meter.
- 5) Repeat the points 1) 2) to read exactly the LRV (± 0.1) .
- 6) Repeat the points 3) 4) to read exactly the URV (± 0.1)
- 7) Complete the calibration procedure by fitting the multiplication factor label (if any) in the left recess below the display and the engineering unit label in the right recess (see fig. 2).

INTEGRAL DIGITAL DISPLAY MICROPROCESSOR DRIVEN

On the Secondary electronics can be fitted an integral digital display.

It can be used, together with local keys, for transmitter configuration, as well as for display various type of information, from Process Variable to output percentage.

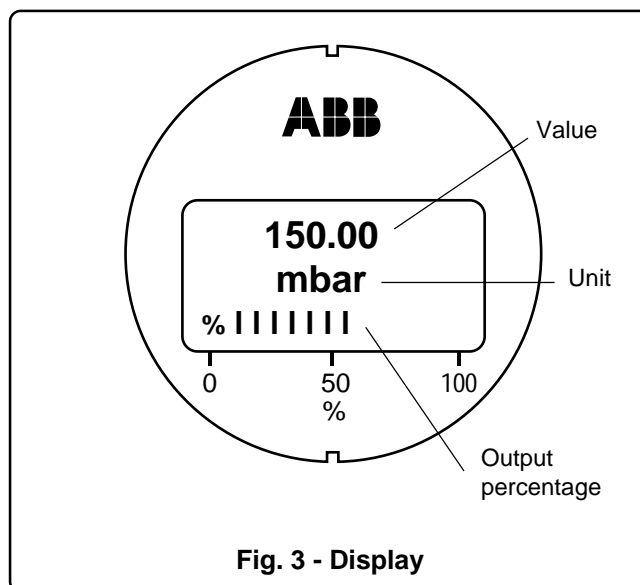

In addition, also diagnostic information are provided, in the way that only the highest priority message will appear and when it disappear, other message, next in priority order, will be given. Here follows a list of error and warning message, in priority order:

- "ELECTRONIC FAIL"
- "SENSOR INVALID"
- "SENSOR FAIL"
- "PV SENS OUTLIM"
- "STATIC PRESS"
- "SENS TEMP"
- "OUT SATUR"
- "OUT FIXED"
- "DAC OUTRANG"

These indication are self explanatory as far as the possible repair action is concerned.

... ADDENDUM FOR "METERS" OPTION OF THE TRANSMITTERS

The integral digital display is an option for the 2600T series transmitter. When it is fitted on the transmitter, the latter automatically detects the presence and allows the use of local keys for operations with the display. The first message that is given, when the display is fitted or at power on is: ABB - HART. Then the indication selected and the bargraph appear, as in the next example.

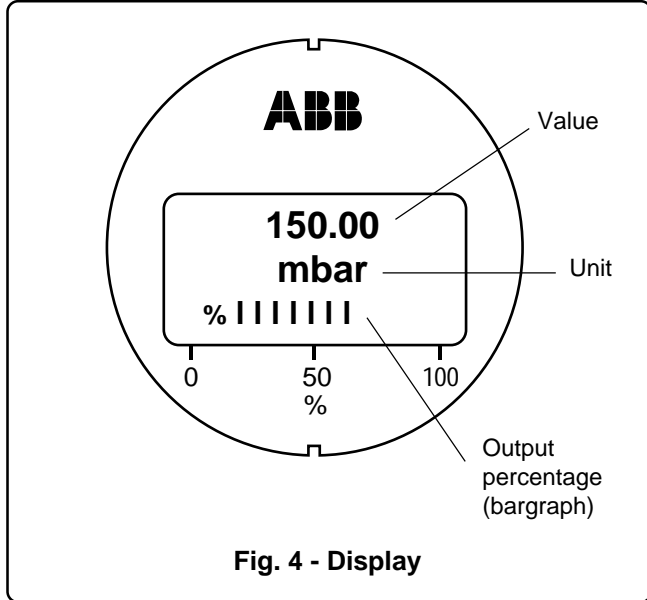

General notes:

To enter the main menu the two local keys must be pressed together, and for at least two/three seconds.

The two keys can be then used in the same way (pressed for more than two seconds) to obtain an ENTER key.

For the ESCAPE key they must be pressed together for only one second.

The use of a single key corresponds to the NEXT and PREV keys and more precisely, the ZERO key for NEXT and SPAN key for PREV. The correct execution causes a VALID message to be displayed, otherwise the message is INVALID.

The following table summarize the main action and message.

Zero key and Span key for three secs.	Enter MAIN MENU and ENTER KEY
Zero key and Span key for only one sec.	ESC key
VALID	Message for OK action
INVALID	Message for action rejected
Zero key	NEXT key
Span key	LAST key

The available option are:

REVIEW: allows the examination of data and parameters

DspCnf: allows the selection of parameter to be displayed and the scale definition

DevCnf: allows the transmitter configuration

SEE_VAR: allows the display of primary and secondary variables

SIMUL: allows the simulation of the analog output and the output trimming

For the change of the numeric values, the position is initially given by the flashing of the digit that can be increased or decreased by the NEXT and PREV key.

Next is the decimal point that can be selected or removed with the NEXT and PREV key.

The ENTER key is used to shift to the next digit, and the ESC key is used to shift to the prev digit.

For the change of the units or another parameter single use the NEXT and PREV key.

Refer to the following diagrams for operations.

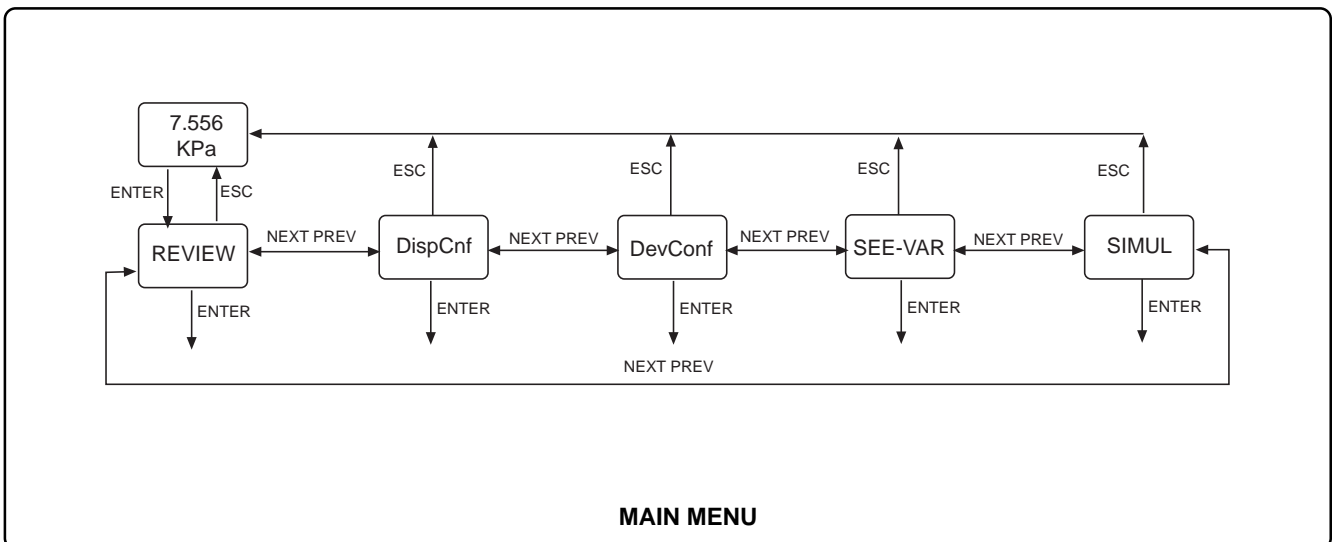

... ADDENDUM FOR "METERS" OPTION OF THE TRANSMITTERS

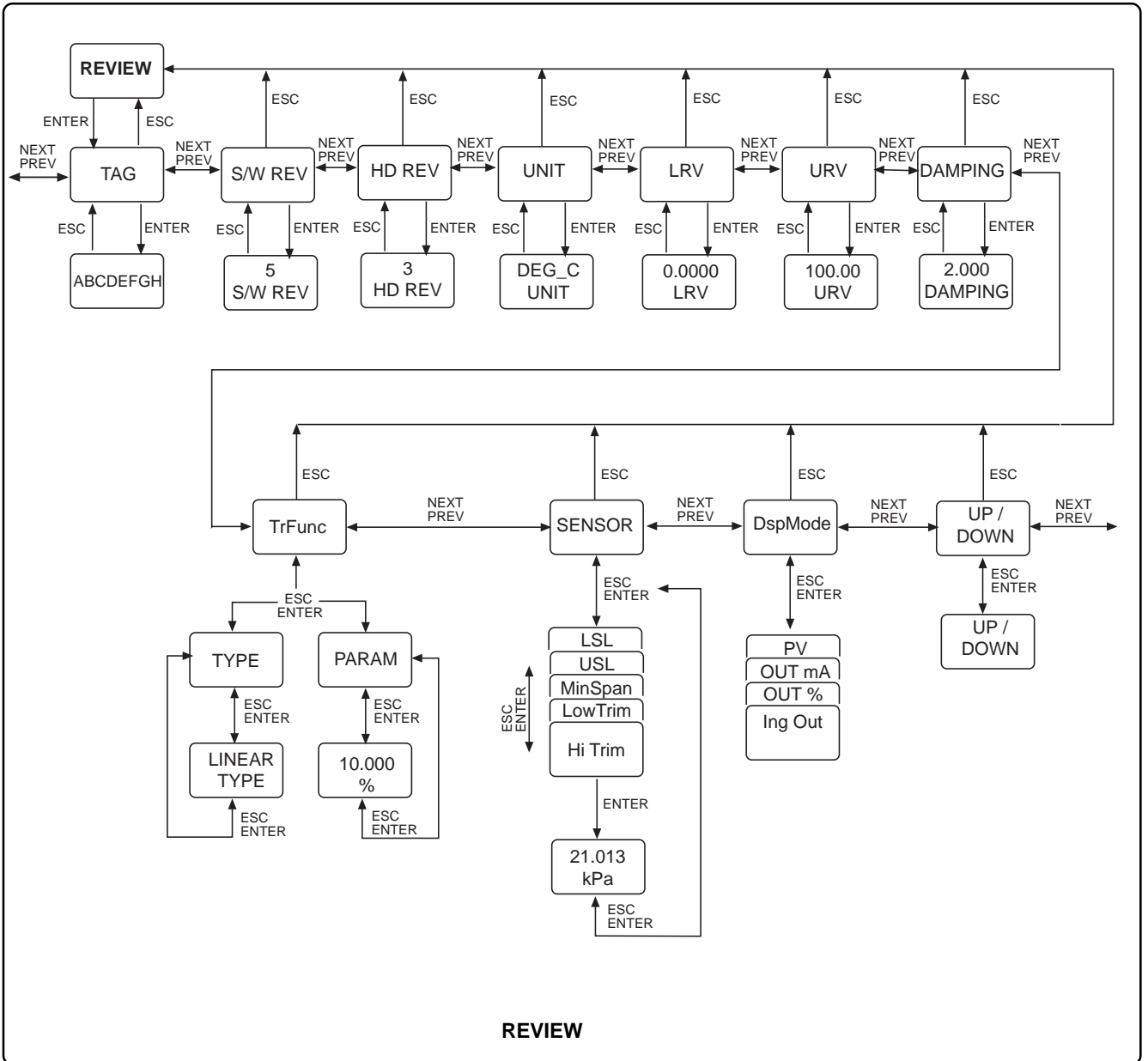

... ADDENDUM FOR "METERS" OPTION OF THE TRANSMITTERS

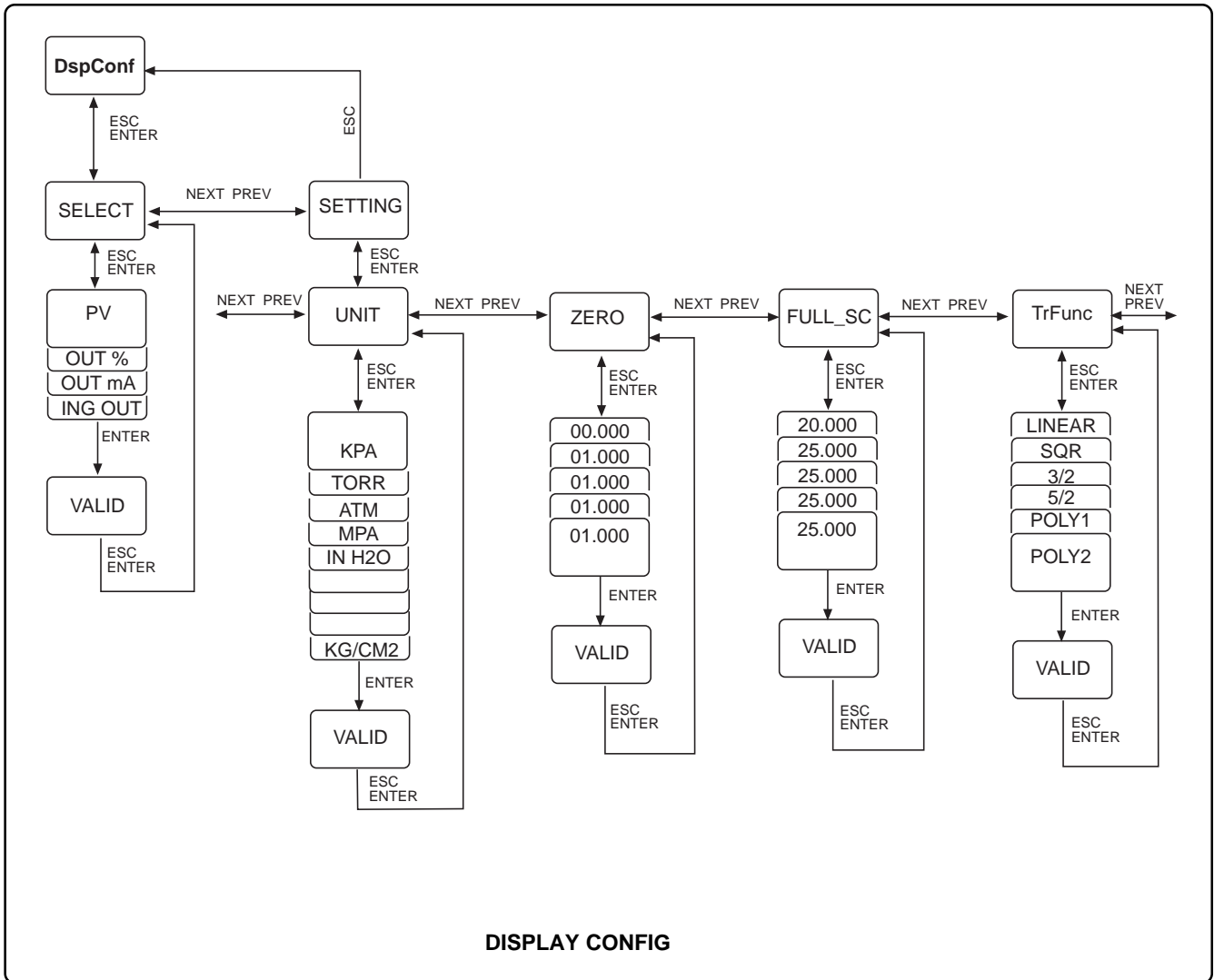

... ADDENDUM FOR "METERS" OPTION OF THE TRANSMITTERS

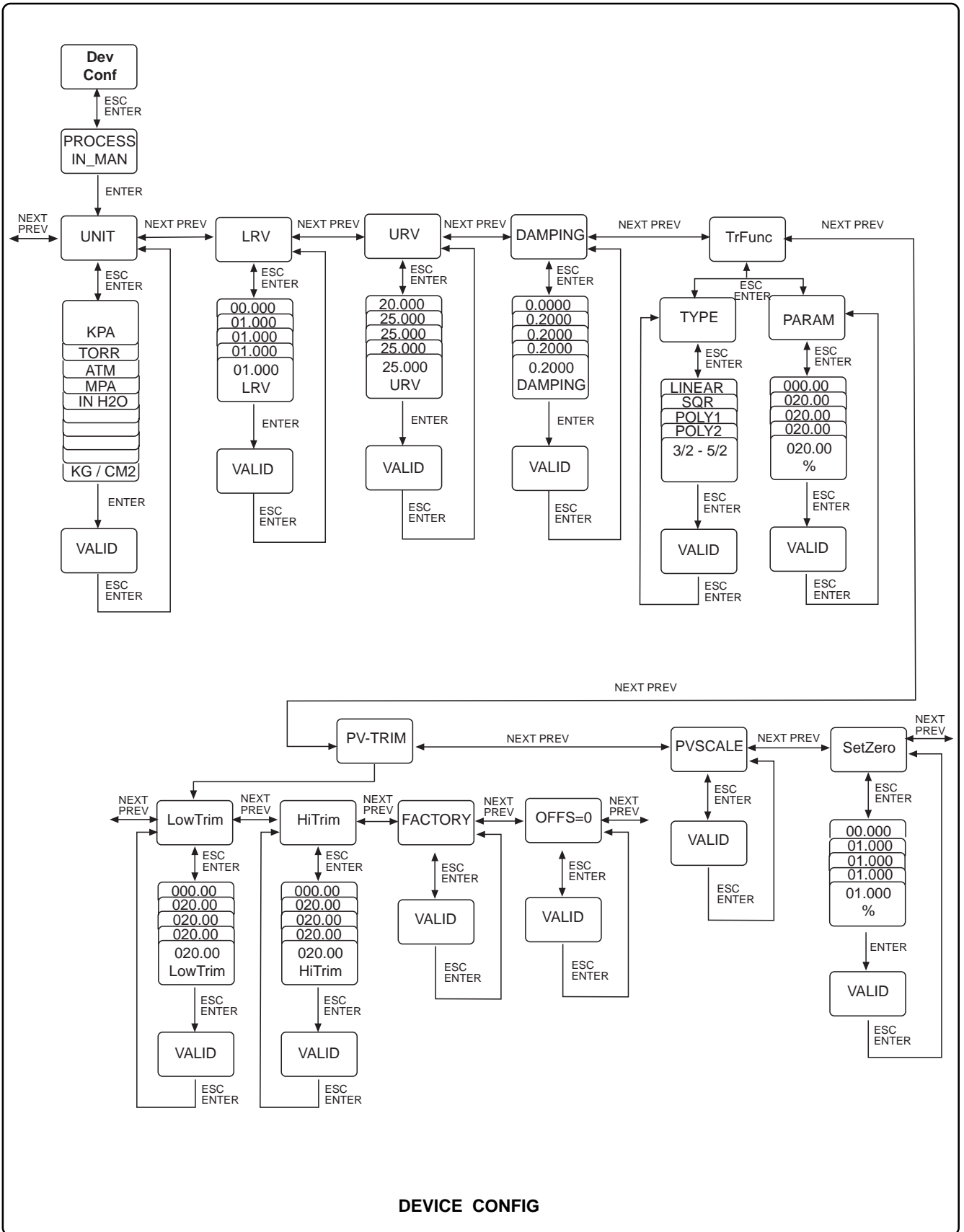

... ADDENDUM FOR "METERS" OPTION OF THE TRANSMITTERS

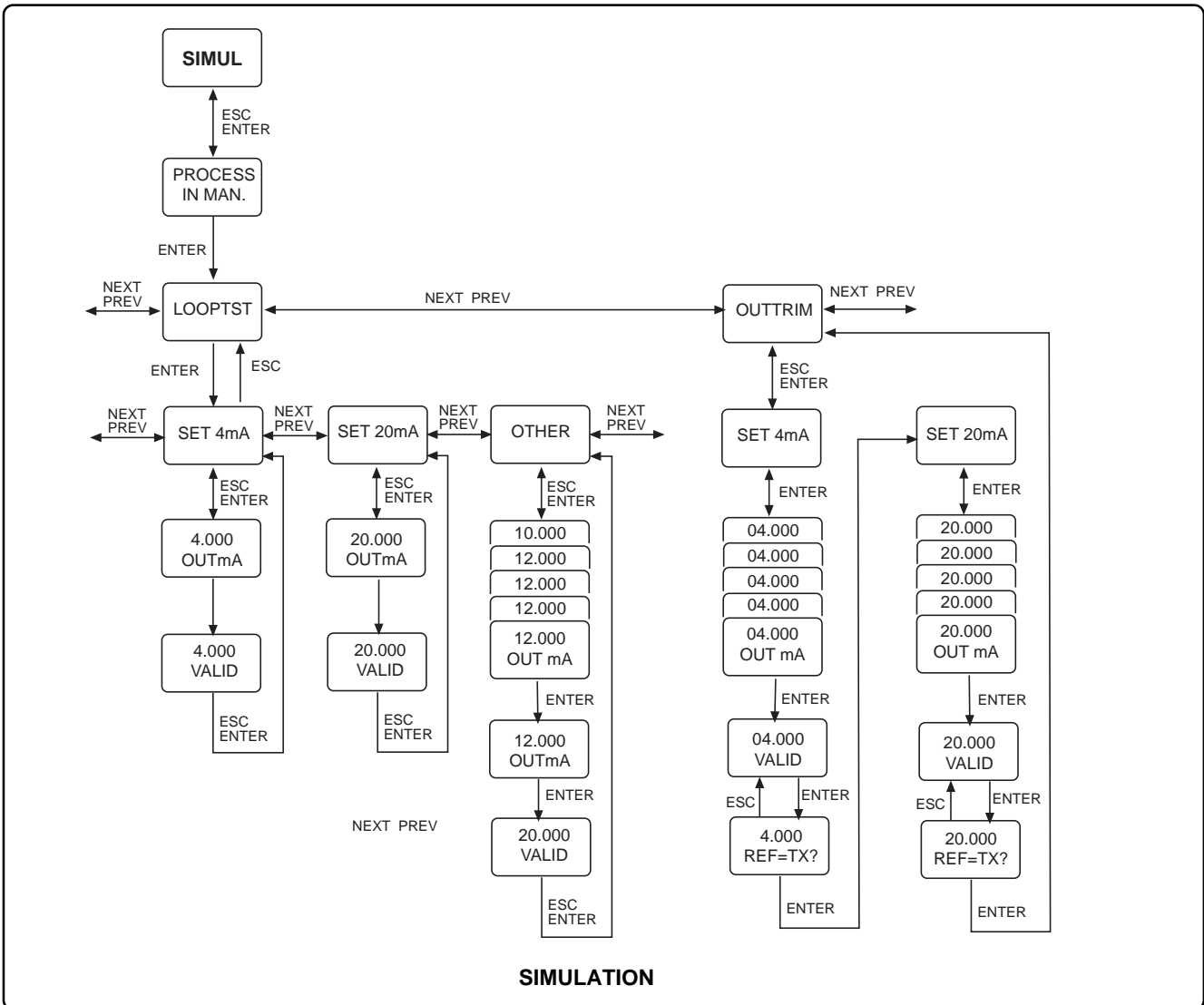
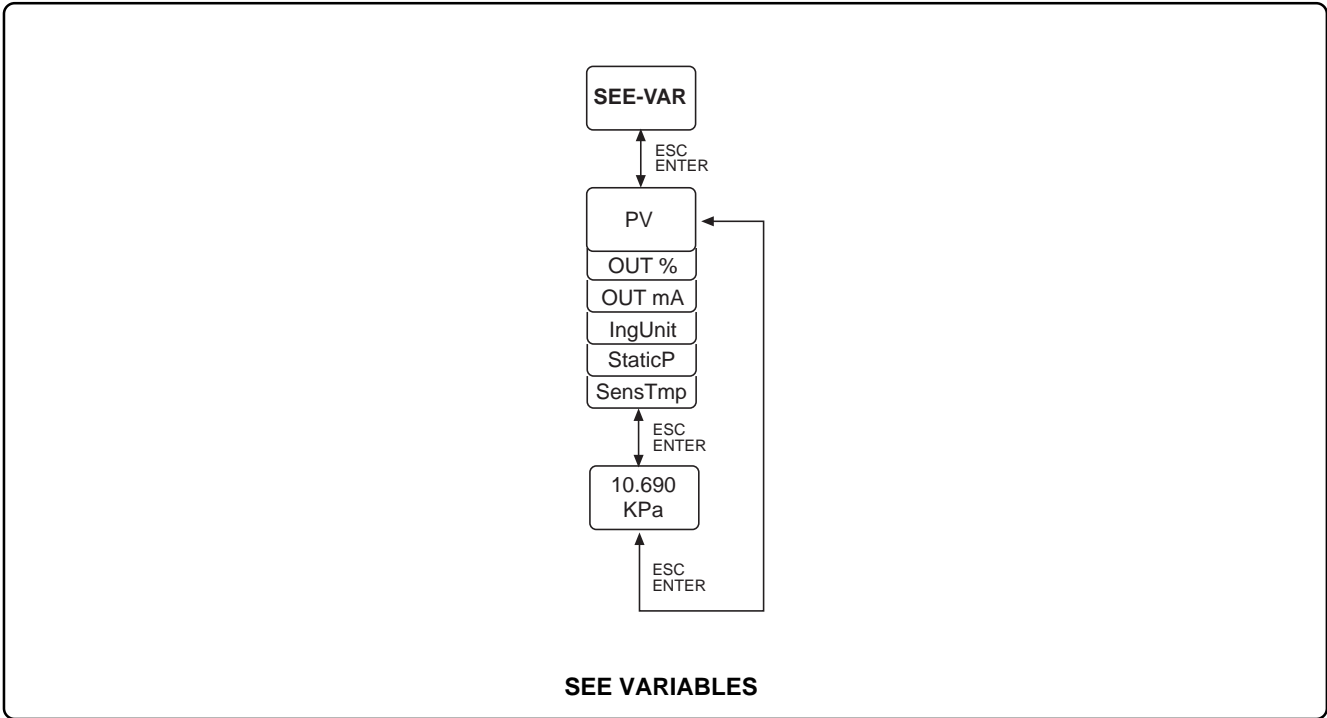

... ADDENDUM FOR "METERS" OPTION OF THE TRANSMITTERS

METER INSTALLATION OR REPLACEMENT



WARNING - If the transmitter is not certified as Intrinsic Safety type, DO NOT REMOVE ANY COVER in areas classified as "HAZARDOUS LOCATIONS: CAN RESULTS IN HAZARD OF FIRE AND EXPLOSION". Contact your Safety Dpt. in order to establish correct installation procedure.

ANALOG OR DIGITAL OUTPUT METER

To install (or to replace) the meter, use the following procedure:

- 1) If the transmitter is part of a control loop, put the loop in manual.
- 2) Remove the cover on the terminal block side; inside of which is affixed the label shown in Fig. 5.

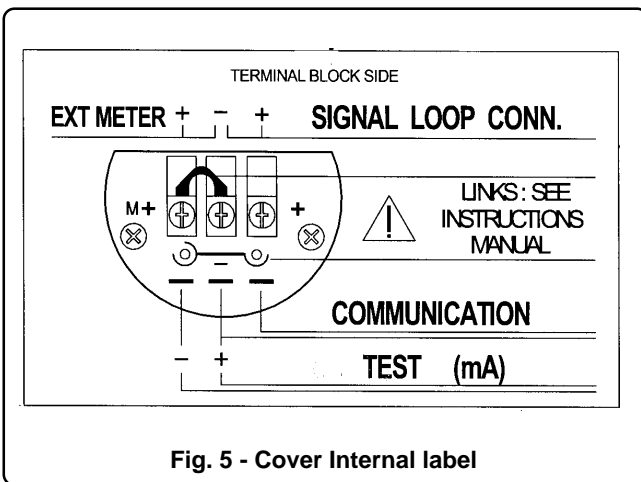

Fig. 5 - Cover Internal label

- 3) Remove the link shown on the label by pushing down at its left extremity and then its right. Alternatively it can be removed on the left side only in preparation for a further refit.
- 4) Plug the meter into the socket. The digital indication meter can rotate, for easy viewing, in 15° steps, 90° degree clockwise and 255° counterclockwise, as shown in figure 2. Further rotation causes damage to the meter stops or to the "banana" connections and should be avoided. Note that considerable effort must be applied for 15° rotation. The analog output meter can also rotate for easy viewing.
- 5) Check that the cover O-ring gasket is properly in place, screw on the extended windowed cover and tighten properly.

To remove the meter simply pull it out from the socket and fit a replacement following the above procedure.



CAUTION - If the meter is removed, ensure that it is replaced immediately by another one or with the proper link provided. **This operation is important for I.S. loop operation.**

INTEGRAL DIGITAL DISPLAY MICROPROCESSOR DRIVEN

The Microprocessor Driven Integral Display can be installed simply by plugging it into the connector provided in the secondary electronics and replacing the blind cover with a windowed one.

To provide an easy view, the indicator can be installed in 4 different positions, in steps of 90°. The indicator is provided with 4 female connectors, equally spaced at 90°, while the secondary electronics is provided with one female connector, marked "METER". An 8 pin insert, supplied with the meter, should be positioned in order to connect the two female connectors with the indicator in the required position.

Proceed as follows:

- 1) **Switch Off the transmitter power supply**
- 2) Remove the blind cover in the electronics side. Verify the correct position of the hardware links (Refer to the proper ADDENDUM).
- 3) Fit the insert in to the electronics connector, place the indicator in the required position, check that the connectors match, and push, with both thumbs, until the two parts hook together.
- 4) Screw on the windowed cover.
- 5) Switch on the transmitter power supply

To replace a Microprocessor Driven Integral Display proceed as follows:

- 1) **Switch Off the transmitter power supply**
- 2) Remove the windowed cover in the electronics side. Lift gently the 4 plastic hooks and disengage the display from the secondary electronics.

Proceed now as indicated at point 3) to 5) above and don't forget to adjust the hardware links on the display.

ADDENDUM FOR COMETER - ANALOG LCD INDICATOR WITH HART PROGRAMMING CAPABILITY

The name **CoMeter** is an acronym for **COMMUNICATING METER**.

It can be connected, plug & play, into the standard terminal block of the 2600T Series Pressure Transmitter.





It is capable to provide both reading and configuration operations, when used in connection with the analog-only version, obviously its functionality is intended as programmable meter. The LCD display has three lines; the first one is used for 5 numeric characters, up to 99999, plus a minus (-) sign on the left and a star (*) sign, up on the right, to indicate HART communication is in progress;

the second line is a 10 segments bargraph used to show the output, from 0% to 100% in 10% steps;

the third line is used for seven alphanumeric characters to display units or messages.

In addition to the display the plastic membrane has 4 push buttons used for programming and for menus navigation.

And more precisely, they are:

- top left position: **ESCAPE** key 
- top right position: **ENTER** key 
- bottom left position: **NEXT** key 
- bottom right position: **PREVIOUS** key 

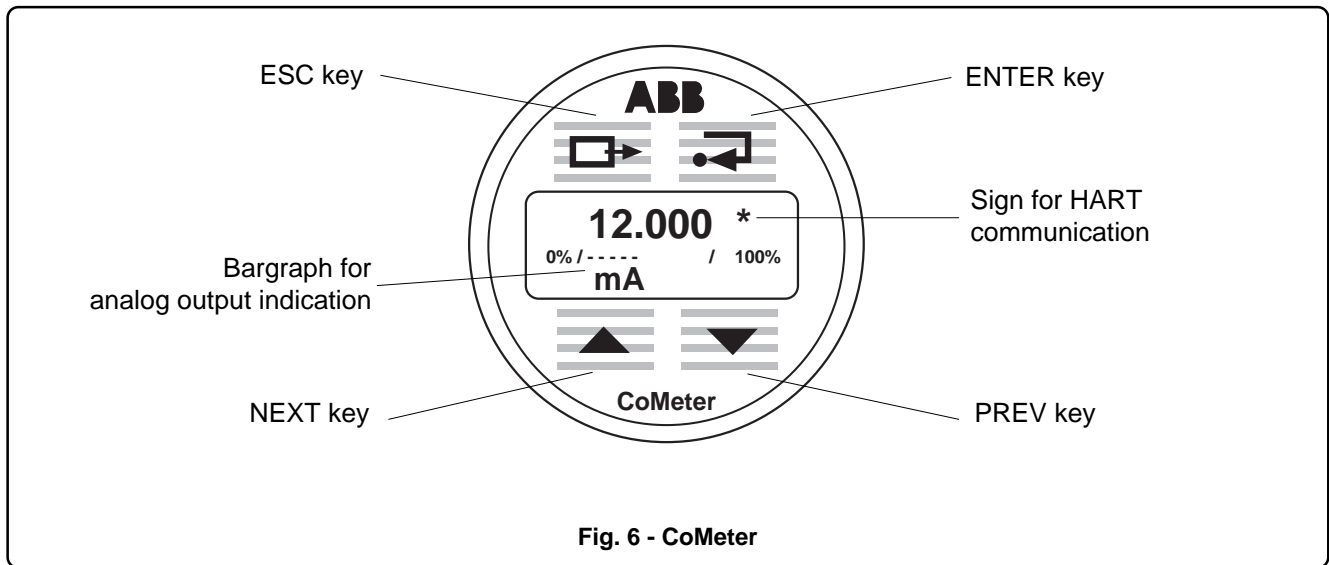

The normal operating condition for the CoMeter is to display the analog output signal of the transmitter, expressed in milliAmpere (this is the default setting), or in percentage or in engineering unit, with all the units available as for the HART Communication Protocol.

In addition to the indicator functionality, the CoMeter can be used as a configuration tool, where both the CoMeter itself and the transmitter can be configured.

In fact, two are the main menu : **ConF METER**" and **"ConF XMTR"**.

ACCESS TO CONFIGURATION

To enter these menù the keys **PREV** and **NEXT** must be pressed simultaneously for 3 seconds, then the user can switch between the XMTR and the METER configuration using the **NEXT** and the **PREV** key.

*** NOTE:** when the Configuration action is finished, remember to press the **ESC** key to return to display the previous selected value.

ConF METER - METER CONFIGURATION

PASSWORD

The access to the configuration menus can be protected by a 5 digits numeric password.

It is under the ConF METER menu that the password can be defined and enabled.

See figure 6 for the access to the **"ConF PASSWORD"** menu. Once you have entered the **"ConF PASSWORD"** menu the cursor is blinking on the most significant digit.

Press **ENTER**, if you want to change the digits, initially set to zero (0).

Use the **NEXT** and **PREV** key to increase or decrease the value of the single digit, use the **ENTER** key to move the cursor to the next digit, use the **ESC** key to move back to the previous digit. When the string **"UPDATE?"** appears on the display you can use the **ENTER** key to accept the new password or the **ESC** key to abort the password definition.

When all digits are set to zero, the password is disabled.

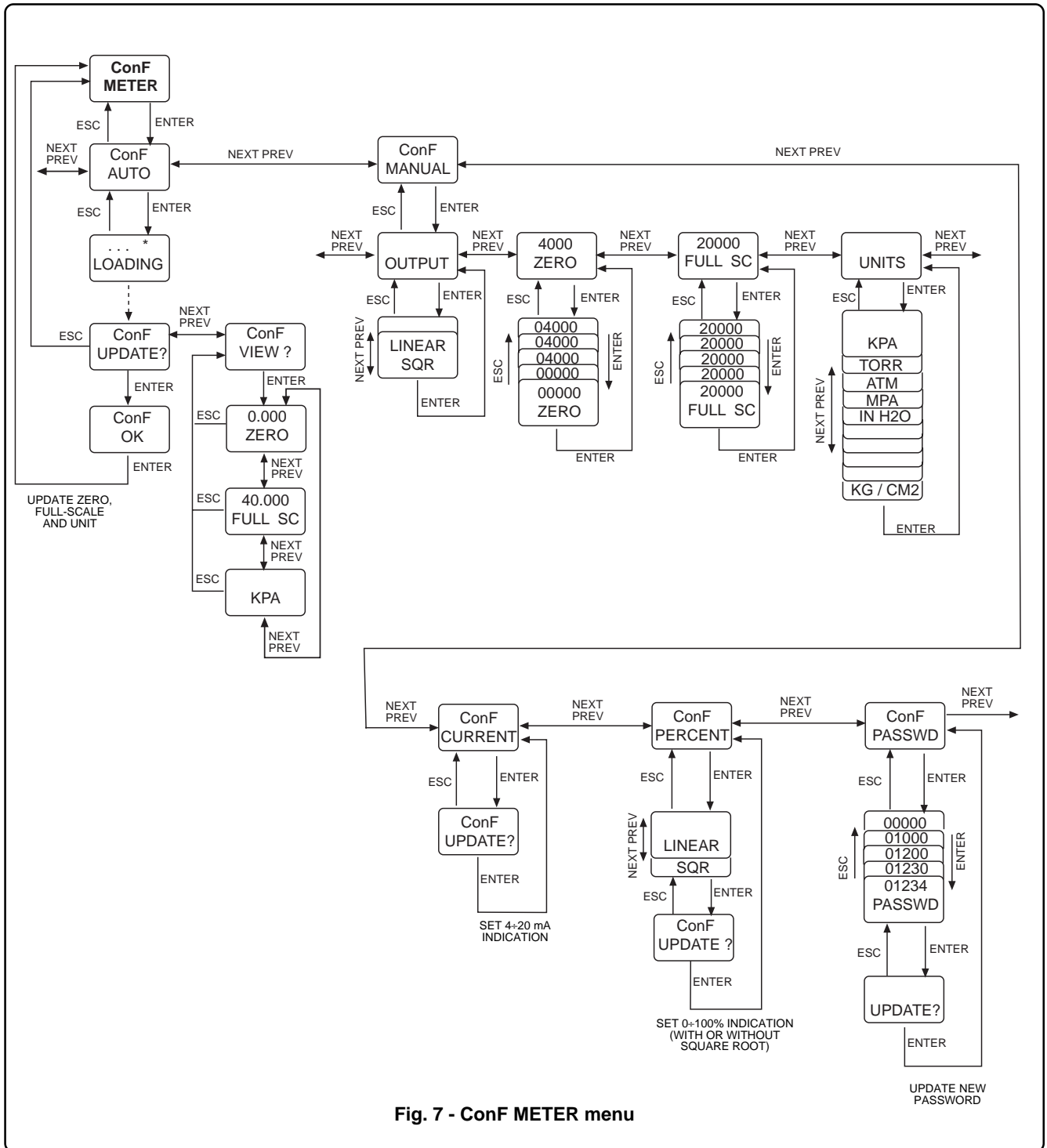

Fig. 7 - ConF METER menu

The other options under ConF METER menu are:

ConF AUTO

By selecting this option, the CoMeter is automatically updated with the LRV, URV and Unit of the HART transmitter connected. Before accepting the transmitter configuration by pressing ENTER at the request "ConF UPDATE?", it is possible to view the LRV (ZERO), the URV (FULL SC) and the UNIT.

If the output transfer function of the transmitter is not linear, the CoMeter shows the message: **ConF NO_LIN** and the user cannot update the configuration.

It is necessary to change the output transfer function of the transmitter to linear.

See Fig. 7 - "ConF METER" menu, for ConF AUTO procedure.

ConF MANUAL

The selection of MANUAL configuration allows the user to define manually the CoMeter configuration, i.e. define the LRV (ZERO), the URV (FULL SC), and the UNIT, as well as to decide for a LINEAR on SQR output function. LRV and URV can have a value between -99999 and +99999. Refer to Fig. 7 - ConF METER menu for detail on the procedure. For having the CoMeter to display the analog output current or the output percentage, select respectively:

ConF CURRENT and ConF PERCENT

ADDENDUM FOR COMETER - ANALOG LCD INDICATOR WITH HART PROGRAMMING CAPABILITY

Under **ConF PERCENT** option, the user can decide for linear or SQR output. When SQR output is selected, the output is linear from 0 to 20% (to 4% of input). Refer to Fig. 7 - ConF METER for details on the procedures.

ConF XMTR - TRANSMITTER CONFIGURATION

Four are the operations under the ConF XMTR menu: **CONF**, **TRIM**, **REVIEW** and **PV**.

By pressing ENTER on the ConF XMTR menu, the string **LOADING** appears on the display, with the blinking star (*) indicating communication activity, i.e. the CoMeter is reading the transmitter information.

Then the **CONF** option appears.

Using PREV or NEXT key, the user can select **CONF**, **TRIM**, **REVIEW** or **PV** option, and with the ENTER key he moves into the menu.

When entering CONF and TRIM menu a message "**LOOP IN_MAN**" appears to remind that a modification can change the transmitter output, so for security the loop should be put in Manual.

See below a list of the available operation under the selected option:

CONF menu	TRIM menu	REVIEW menu	PV menu
Change LRV Change URV Change DAMPING Change UNITS Change OUTPUT	Reranging (RERANG.) Loop test (LOOPST) Output trim (OUTTRIM) Zero adjustment (SNSZERO)	TAG 8 Final Assembly Nr. (XMTR N.) Sensor Serial Nr. (SENS N.) Up/Down scale (UP/DOWN) UNITS LRV URV LRL (See Sensor Units) URL (See Sensor Units) DAMPING OUTPUT	Primary variable (PRIMARY) Secondary variable (2ND) Tertiary variable (3RD) Fourth variable (4TH)

Use PREV or NEXT key to scroll through the options and ENTER key to change or view the values.

The procedure to change the numeric value remains the one already explained for PASSWORD operation, i.e., the cursor starts blinking on the most significant digit, then use the NEXT and PREV key to increase or decrease the value of the single digit (the minus sign(-) automatically appears or disappears when the value increases above 9 or decreases below 0, as well as for the decimal point(.). Use the ENTER key to move the cursor to the next digit, use the ESC key to move back to the previous digit. An ENTER on the last digit will cause the value to be sent to the transmitter.

Refer to figures 8, 9, 10 and 11 for details.

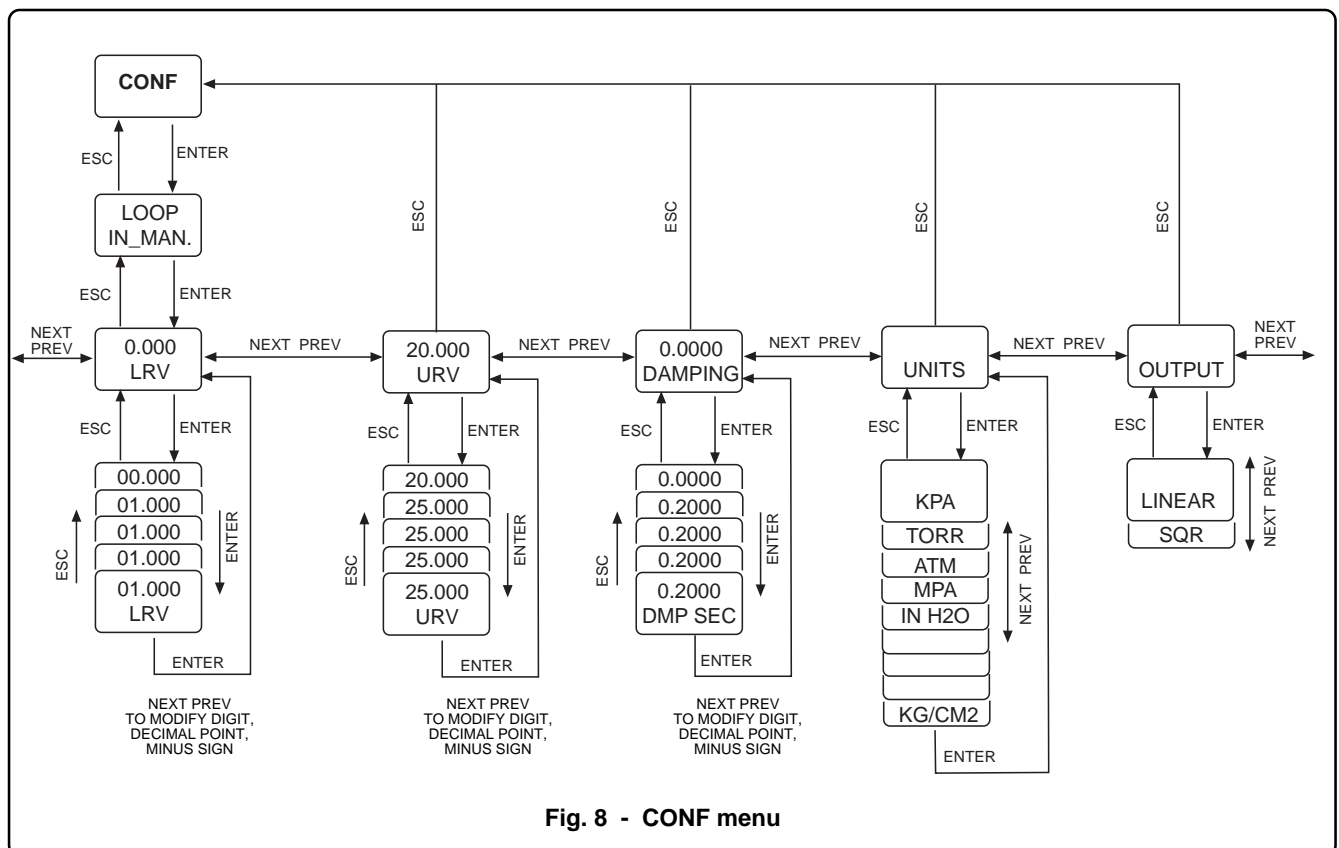

Fig. 8 - CONF menu

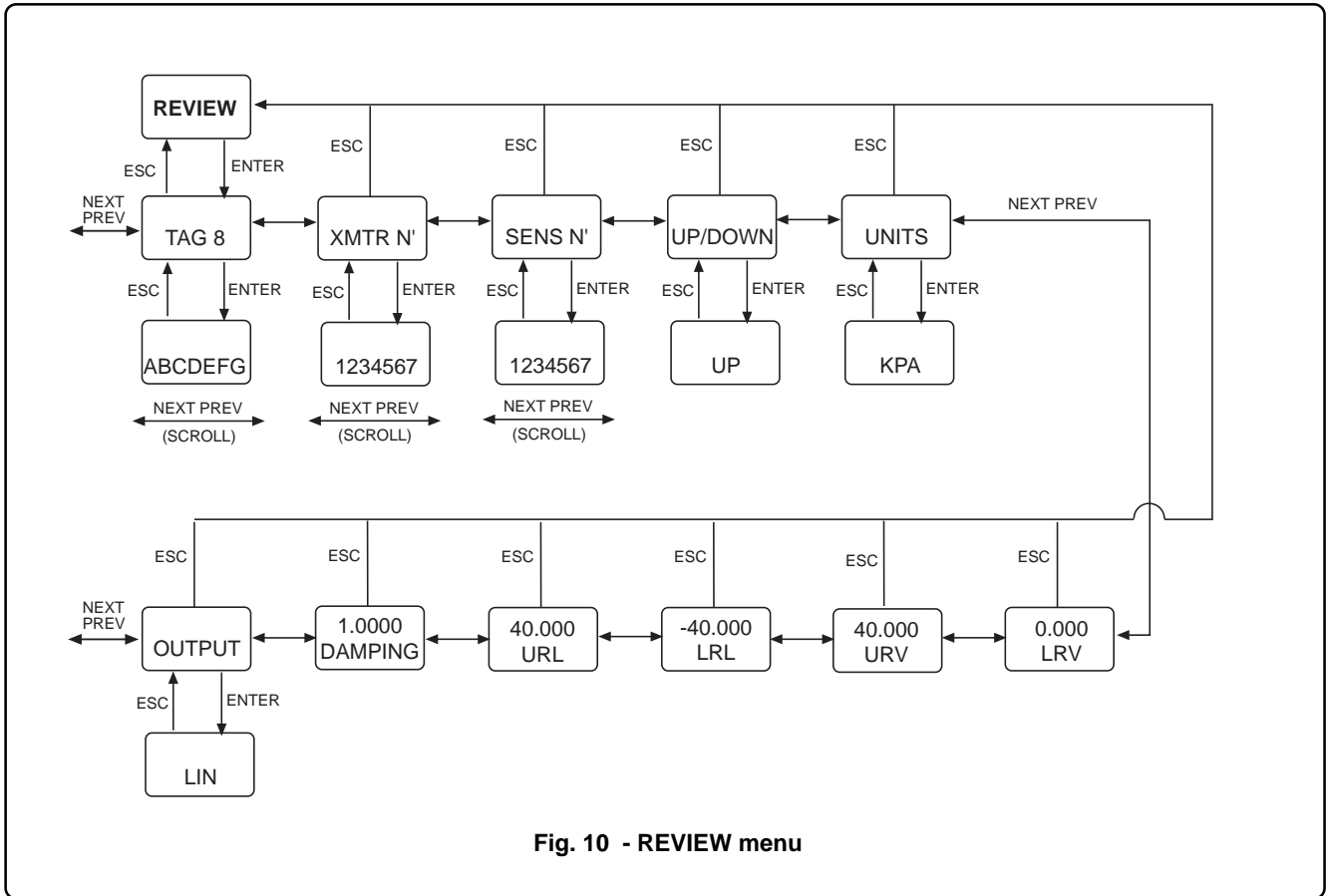

Fig. 10 - REVIEW menu

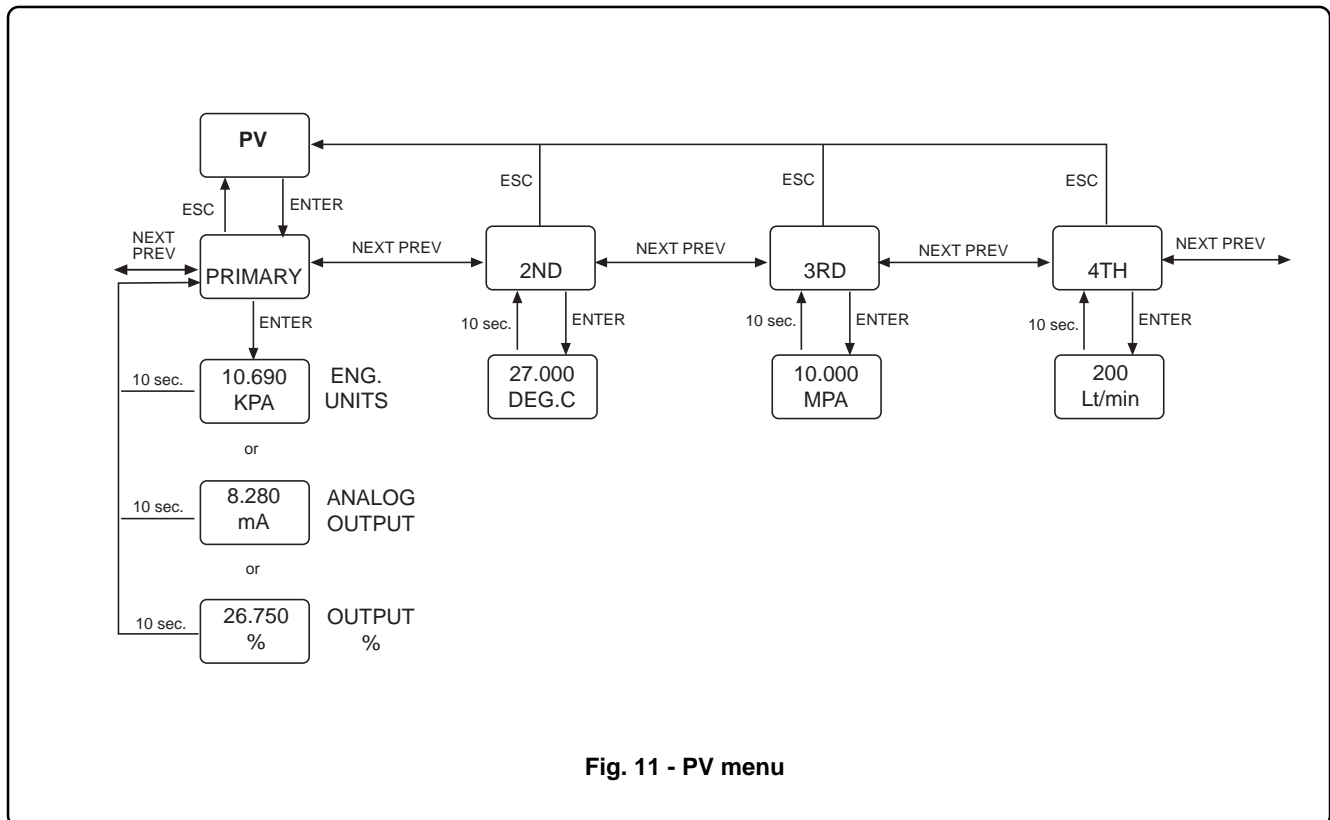

Fig. 11 - PV menu

ADDENDUM FOR PV-SCALING OPERATION

PV-scaling operation can be used to align the "zero" of the process with the "zero" reading of the transmitter. A configuration tool must be used to perform this operation through digital communication.

There are two different ways to perform a PV-scaling.

Method 1: apply to the transmitter a pressure that corresponds to the scaling value (offset) you have to apply to the reading and perform the operation using the configuration tools. The operation is called SET PV ZERO (see example 1).

Method 2: calculate the scaling value (offset) and apply it to the transmitter following the operation available on the configuration tool. With this method it is possible to perform a scaling operation even for a value different than zero. The operation is called SET PV VALUE (see example 2).

Effect of the PV-scaling operation:

An example can better explain the effect of the scaling action.

Example n° 1

the transmitter is calibrated at:

LRV = 0 mbar

URV = 200 mbar

the transmitter model has the following limits of operation:

LRL = -400 mbar

URL = +400 mbar

For the effect of a transmitter's capillary, connected to a tank, there is a pressure of 80 mbar when the tank is empty, i.e. the transmitter's reading is 80 mbar.

In order to eliminate the pressure caused by the fluid inside the capillary, you can perform a PV scaling for compensating/scaling the reading for these 80 mbar. The result of this operation is:

the transmitter's reading is now 0 mbar.

offset is -80 mbar and must be considered that while the limits of the transmitter remains:

LRL = -400 mbar

URL = +400 mbar

and the calibration does not change

LRV = 0 mbar

URV = 200 mbar

The configuration tools allows you to evaluate the new operative limits:

operative LRL = -480 mbar

operative URL = +320 mbar

Example n° 2

the transmitter is calibrated at:

LRV = 0 mbar

URV = 200 mbar

the transmitter model has the following limits of operation:

LRL = -400 mbar

URL = +400 mbar

the transmitter is reading:

PV = 100 mbar

and you know the process value is 50 mbar.

You can apply this 50 mbar for your PV scaling operation, with similar effect as per the previous example:

PV reading = 50 mbar

offset = 50 mbar so that while the limits of the transmitter remains:

LRL = -400 mbar

URL = +400 mbar

with no change for the calibration, the configuration tools allows you to display the new operative limits:

operative LRL = -450 mbar

operative URL = +350 mbar

When requested it is possible to reset the value actually applied as offset.

When an offset is defined, the trimming operations are disabled and can be rehabilitated only by eliminating the scaling, i.e. setting the offset to 0.

ADDENDUM FOR "SURGE PROTECTION" OPTION OF THE TRANSMITTERS

GENERAL DESCRIPTION

This option provides a built-in surge protection circuit.

The surge protector is designed to dissipate large quantities of electrical energy which have been induced in a transmission line. The option is suitable to protect up to 2500 V (5 kA discharge current) of 8 μ s rise time/20 μ s decay to half value.

These large quantities of energy can be induced in the signal transmission line by lightning discharge in the area or by nearby electrical equipment.

The dissipation of this energy prevents damage to transmitter circuitry connected to the transmission line.

The surge protector will not protect the instrument in case of a direct lightning strike.

The surge protector board is located inside the terminal block of the transmitter (see drawing).

The circuit is designed to operate and recover automatically. It does not require periodic testing or adjustment.

FITTING PROCEDURE



CAUTION : This procedure should not be carried out on the field site.

- a) Remove the transmitter cover of the field connections side.
- b) Unplug the built-in indicator, if present.
- c) Unscrew the two Phillips screws (M 4 x 18 mm) which secure the terminal block and pull it off the housing.
- d) Unweld the + and - wires which connect the two RF (radio frequency) filters, on the back of the terminal block.
- e) Fit properly the surge protector p.c. board and secure it by a self-tapping screw (M 2.9 x 6mm)
- f) Secure the two +/- eyelet terminals to +/- holes on the back of the terminal block, by a welding operation.
- g) Secure the two +/- wire eyelet terminals of the RF filters to the +/- bushes of the p.c. board by a welding operation.
- h) Connect the wire eyelet terminal of the Surge Protector to the dedicated ground connection below terminal block, using a provided self tapping screw M4x8 mm and relevant washers.
- i) Reinstall the terminal block and stick on the notice label in the proper position.
- l) Plug the built-in indicator, if used.
- m) Refit the cover.

Refer to Fig. 1 and also follows the indication in the figures 2a and 2b.

In the first one (2a) you can see the terminal block connection when there is no surge protector applied.

In the latter (2b) you can see the terminal block connection when surge protector is in!



NOTE - The Surge Protector is suitably provided with the necessary installation screws and the notice label.

Adding the unit to an existing transmitter will affect the power supply requirement for a minimum added operating voltage of 1.6 V d.c.

... ADDENDUM FOR "SURGE PROTECTION" OPTION OF THE TRANSMITTERS

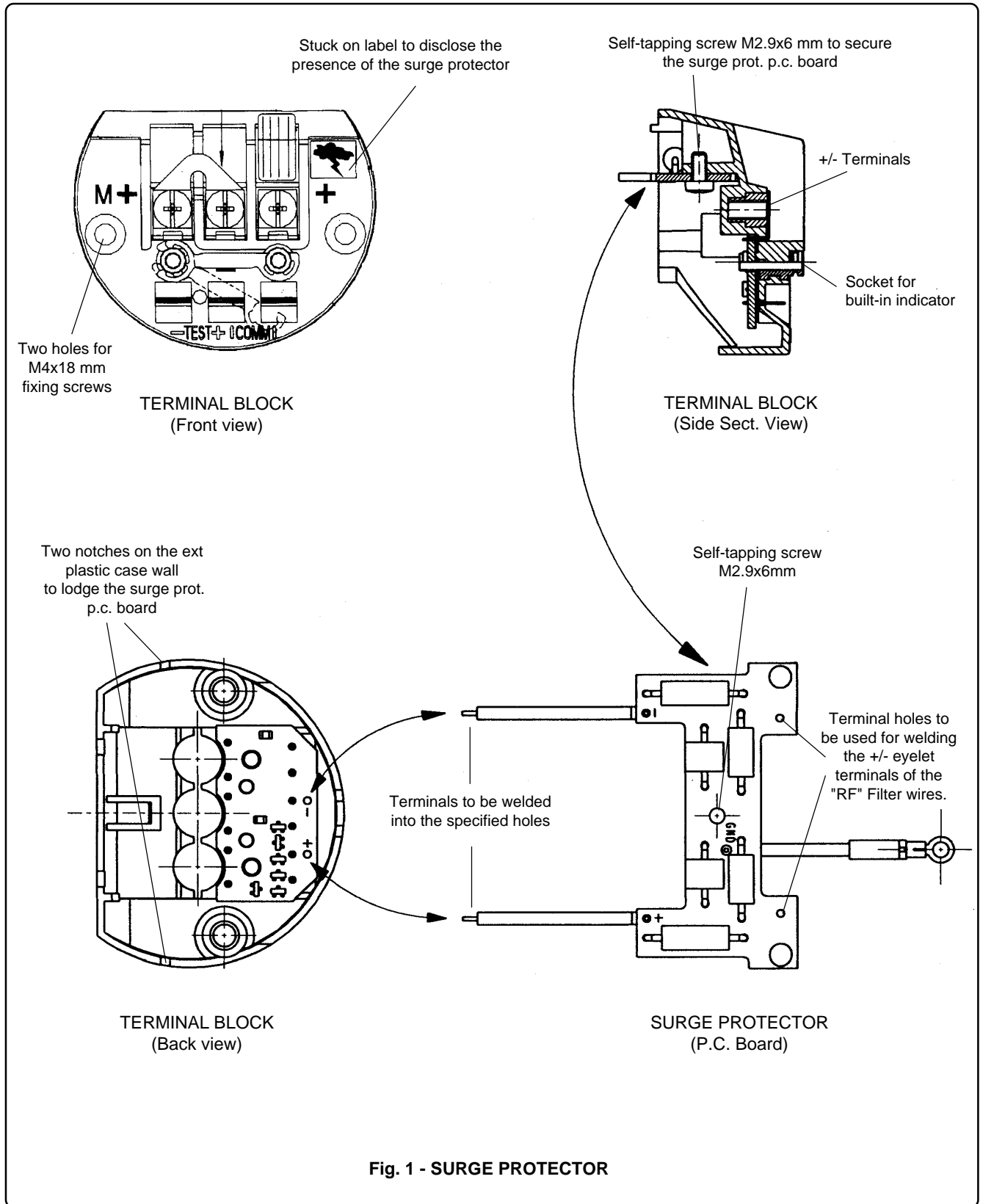

... ADDENDUM FOR "SURGE PROTECTION" OPTION OF THE TRANSMITTERS

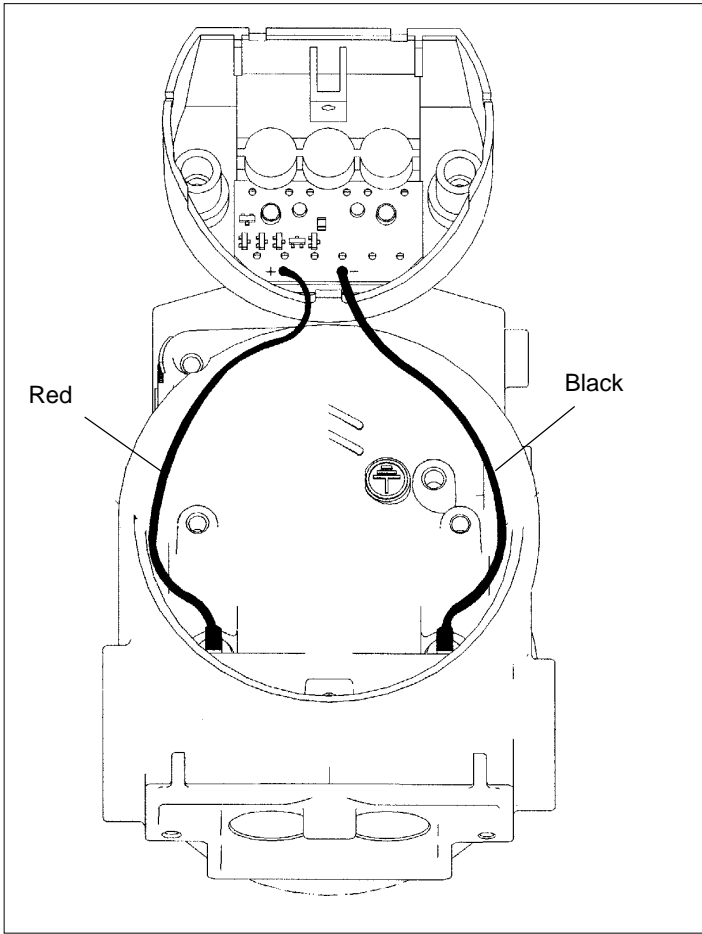
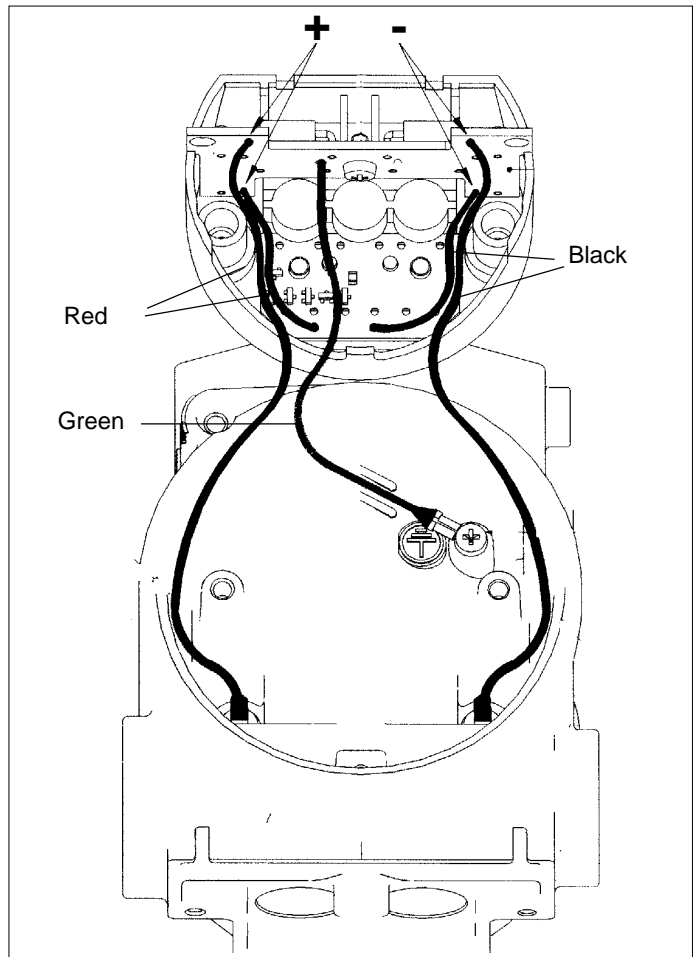

Fig. 2a
Connection for terminal block and housing.

Note: Before to fix the terminal block to the housing put the two wires in the position as shown above, in order to avoid any damages.

Fig. 2b
Connection for terminal block and housing, with surge protection.

Note: Before to fix the terminal block to the housing put the two wires in the position as shown above, in order to avoid any damages.



ADDENDUM USE OF HARDWARE LINKS ON THE SECONDARY ELECTRONICS

A picture of the secondary electronics is given. There are 6 dip switches located on the secondary electronics as indicated below; they are used for settings when integral digital display is not available.

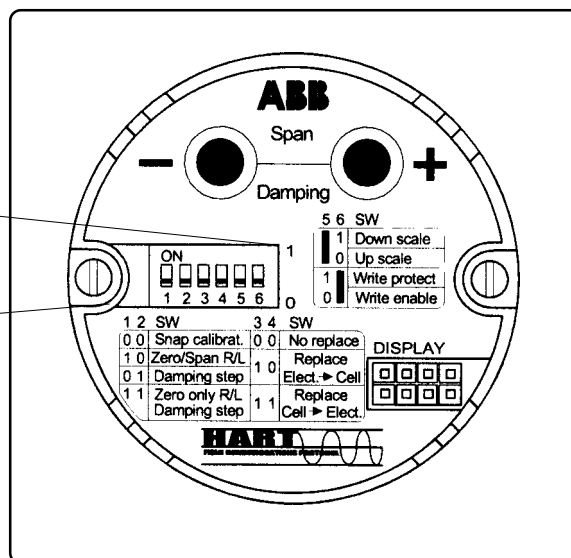

Switch 1 and 2 are used for Snap Calibration, Zero and Span Raise/Lower and also for Damping step.

Switches 3 and 4 are used for Electronics or Transducer replace

Switch 5 is for Write Protect mode selection

Switch 6 is for Up/Down Scale selection

Now follows a description of the operations.



ZERO / SPAN SNAP CALIBRATION

With switches 1 and 2 down in position, ZERO and SPAN local adjustment, located below the nameplate of the transmitter housing can be used for ZERO (4-mA point), and SPAN (20 mA point), adjustment, i.e. range calibration.



ZERO / SPAN - RAISE / LOWER

When switch 1 is moved on in "1" position, ZERO/SPAN Raise/Lower is active. The usage of - and + buttons on the secondary electronics causes respectively an increment and a decrement of the SPAN value (URV); ZERO and SPAN local adjustment under the nameplate allows ZERO value (LRV) increment or decrement.



DAMPING RAISE / LOWER

With switch 2 up in "1" position, DAMPING Raise/Lower is active. Use - button and + button on the secondary electronics to respectively decrement and increment the damping value. Acceptable values for damping are: 0 - 0,25 - 0,5 - 1 - 2 - 4 - 8 and 16.

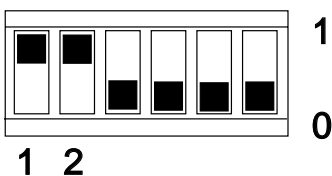

ZERO / DAMPING - RAISE / LOWER

When switches 1 and 2 are up in "1" position, both ZERO and DAMPING Raise/Lower can be performed. Use - button and + button on the secondary electronics to respectively decrement and increment the damping value. Use ZERO and SPAN local adjustment under the nameplate for ZERO value (LRV) increment or decrement.

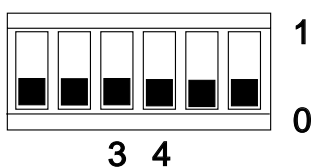

REPLACE

Usually switches 3 and 4 are down in "0" position. They are moved when a replace operation is required.



Switch 3 up in "1" position is required before power up the transmitter, when a replace of the electronic is being performed.



Viceversa switch 4 up in "1" position allows the replace of the transducer. It must be moved in this position, when transducer replace is being performed, before power up the transmitter.

WRITE PROTECT mode



With the switch 5 up in ON position the write protect mode is active. It is a way to protect the device from any change: configuration data and parameters cannot be modified.

UP/DOWN SCALE mode

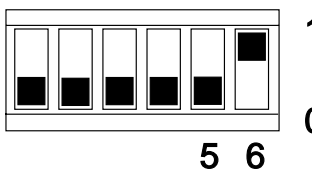

The switch 6 defines the fail safe output condition in case of transmitter failure:

- In the ON position the output is Down (below 4 mA and more precisely 3,6 mA);
- In the OFF position the output is UP (above 20 mA and more precisely 21, 8 mA)



NOTE: The message **WRITE DISABLE** appears on the integral digital display when Write Protect Link is in Protect position. The message **ZERO DSBL** or **SPAN DSBL** appears on the integral digital display when ZERO and SPAN local adjustment are disable. Zero and Span can be disabled using a HART configuration software.



NOTE: Typically the Up/Down scale mode is activated when there is a failure in the physical elements of the sensor and on the electronics of the device, and more precisely:

- 1) Values in the sensor database are corrupted;
- 2) EEprom of Primary Electronic (sensor) is failed;
- 3) Values of Primary and Secondary variables are out of limits;
- 4) Digital to analog converter (DAC) circuit is out of range.
- 5) ASIC - (Integrated circuit) of sensor is failed.
- 6) ASIC - (Integrated circuit) of electronics is failed.

These failure will cause diagnostic messages to appear on the integral digital display:

- 1) ELECTRONIC FAIL
- 2) SENSOR FAIL
- 3) SENSOR INVALID
- 4) DAC OUTRANG

ADDENDUM FOR SELECTABLE OUTPUT FUNCTIONS

GENERAL DESCRIPTION

The 2600T Series Pressure Transmitter can be selected with a linear, a "polynomial" output function, for input linearization using a 5th order polynomial function, or for input linearization using 2 polynomial functions of 2nd order. Also a Constant Current function can be chosen for loop or associated equipment test.

1.0 LINEAR

Using this function, the relationship between the input (measured value), expressed in % of the calibrated span and the output is linear, e.g. at 0% input, corresponds 0% output (4mA), at 50% input corresponds 50% output (12mA) and at 100% input corresponds 100% output (20mA). Available for analog and analog + HART version.

2.0 POLYNOMIAL 1 (5th order)

The polynomial function, applied to the transmitter input (x) expressed in % of the calibrated span, has the following form:

$$\text{Out} = \pm A_0 \pm A_1(x) \pm A_2(x^2) \pm A_3(x^3) \pm A_4(x^4) \pm A_5(x^5)$$

where (x) and Out should be normalized in the range 0 to 1 for calculation purpose, with following Out meaning:

Out = 0 means Analog out 4 mA

Out = 1 means Analog out 20 mA

This function can be used for linearization purpose: the user can plot the characteristic curve of the input and find, using a mathematical method, the parameters of the polynomial that better approximate the plotted curve. Check, after the calculation, if the maximum error is compatible with the application.

The following are some application examples.

2.1 CYLINDRICAL VESSEL

Using the polynomial function applied to a level transmitter installed in a horizontal cylindrical vessel it is possible to transmit the measure of level in term of partial volume. Some different cases should be considered:

a) Cylindrical vessel with flat ends (not often used. Fig. 1a). Transmitter measuring the whole vessel height.

The following polynomial gives the area of the circular section in relation to the height h (height of the liquid in the vessel).

$$\text{Out} = -0.02 + 0.297 h + 2.83 h^2 - 4.255 h^3 + 3.5525 h^4 - 1.421 h^5$$

Being both the input h and the output Out normalized, i.e. in the range 0 to 1 (or 0% to 100%), the vessel diameter corresponding to a circular area equal to 1 (100%) will be "normalized" by a "K" factor of the following value:

$$K = 2 \cdot \sqrt{1/\pi} = 1.12838$$

The volume of the liquid contained in the vessel, at height = h will be

$$V = \text{Out} \cdot (d/1.12838)^2 \cdot L$$

where d = vessel diameter and L = vessel length.

The non conformity error is within 0.1% between 0.5% and 99.5% of h, 0.2% at 0% and 100%.

b) Cylindrical vessel with hemispherical ends (see Fig. 1b). Transmitter measuring the whole vessel height.

The same polynomial can be used also for the cylindrical vessel with hemispherical ends. To obtain the volume contained in the vessel can be used the following empirical formula:

$$V = \text{Out} \cdot (d/1.12838)^2 \cdot (L + 2/3 d)$$

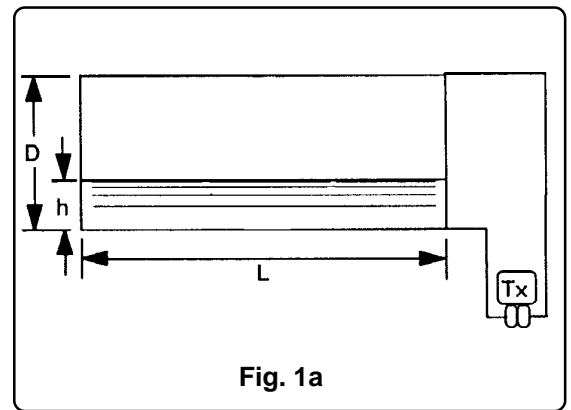

Fig. 1a

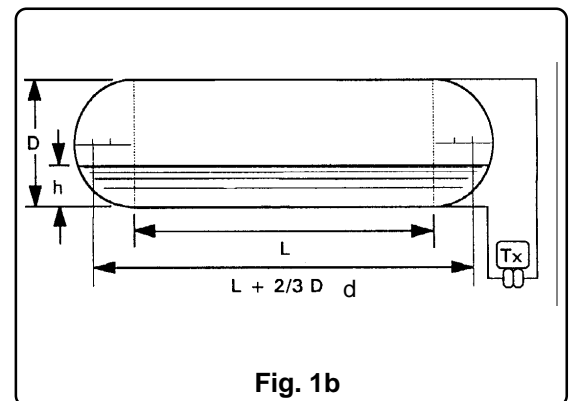

Fig. 1b

... ADDENDUM FOR SELECTABLE OUTPUT FUNCTIONS

The non conformity error depends on the ratio between diameter and length of the vessel: for ratio ≥ 5 to 1 the error is $\leq 0.25\%$. The polynomial found with mathematical method gives an error of $\pm 0.15\%$.

c) Cylindrical vessel with elliptical or pseudoelliptical ends (see Fig. 1c). Transmitter measuring the whole vessel height.

The same polynomial can be used also for the cylindrical vessel with elliptical or pseudoelliptical ends. To obtain the volume contained in the vessel can be used the following empirical formula:

$$V = \text{Out} \cdot (d/1.12838)^2 \cdot (L + 2/3 m)$$

where m is the length of the minor ellipse axis (see Fig.1c)

The non conformity error depends on the ratio between the diameter and the length of the vessel: for ratio ≥ 5 to 1 the error is $\leq 0.25\%$. The polynomial found with mathematical method gives an error of $\pm 0.15\%$.

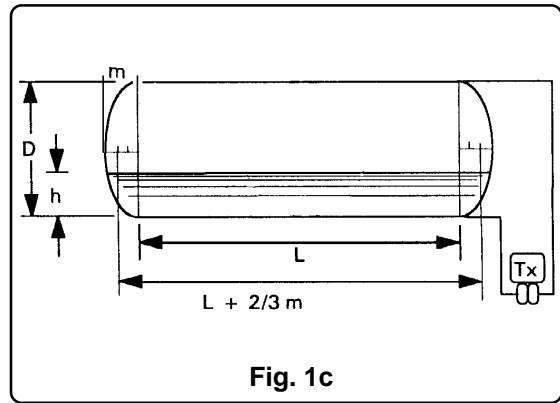

Fig. 1c

2.2 SPHERICAL TANK

Spherical tank (see Fig.1d). Transmitter measuring the whole vessel height.

The following polynomial gives the volume of the spherical section in relation to the height h of the liquid in the tank.

$$\text{Out} = 3 h^2 - 2 h^3$$

This formula is geometrical and then his conformity is perfect.

Being both the input h and the output Out normalized, i.e. in the range 0 to 1 (or 0% to 100%), the sphere diameter D corresponding to a volume equal to 1 (100%) will be "normalized" by a "K" factor of the following value:

$$K = 2 \cdot \sqrt[3]{3/(4\pi)} = 1.2407$$

The volume of the liquid contained in the tank, at height = h will be

$$V = \text{Out} \cdot (D/1.2407)^3$$

where D = sphere diameter .

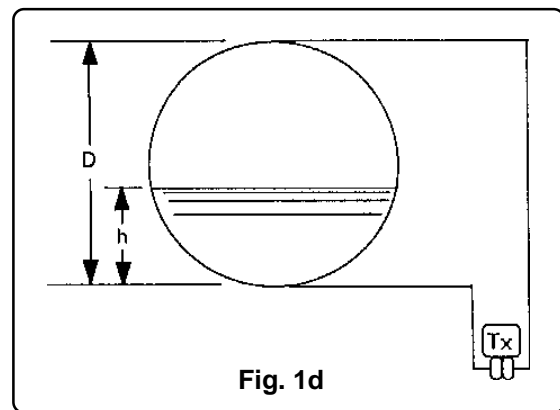

Fig. 1d

2.3 CYLINDRICAL VESSEL AND SPHERICAL TANK WITH PARTIAL LEVEL MEASUREMENT

Cases a) to d) but with partial level measurement (Fig. 2a)

In these cases two methods can be used:

- 1) Plot the changes in volume in relation to the level changes and, using a mathematical method, find the relevant polynomial.
- 2) Use the polynomial coefficients for cases a) to d) and calibrate the transmitter range to cover the full diameter of the vessel or tank: the changes in volume for the h changes between h_0 and h_{\max} will be correct. Of course the transmitter will transmit, when the level is $\leq h_0$, the volume corresponding to h_0 ; the same apply for level $\geq h_{\max}$.
All transmitted volumes are % of the total volume of the vessel.

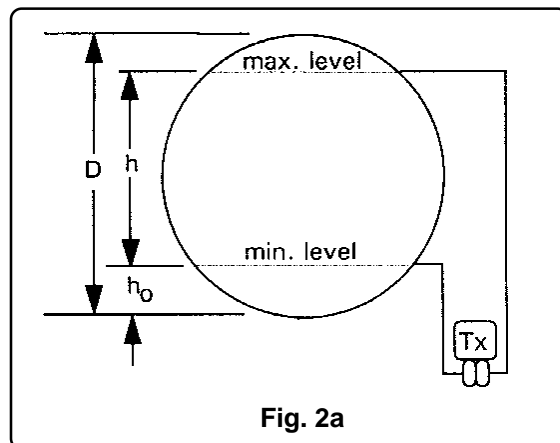

Fig. 2a

If it is required the partial volume starting from h_0 (i.e. the volume at $h_0 = 0$) then the A_0 coefficient should be equal to the polynomial solved for h_0 with negative sign: for example for $h_0 = 20\%$

$$A_0 = -0.02 + 0.297 \cdot 0.2 + 2.83 \cdot 0.2^2 - 4.255 \cdot 0.2^3 + 3.5525 \cdot 0.2^4 - 1.421 \cdot 0.2^5 = -0.14179$$

The polynomial coefficients for the example will be:

$$\text{Out} = -0.14179 + 0.297 h + 2.83 h^2 - 4.255 h^3 + 3.5525 h^4 - 1.421 h^5$$



Note : The accuracy of all above numerical values can not be guaranteed.

... ADDENDUM FOR SELECTABLE OUTPUT FUNCTIONS

3.0 POLYNOMIAL 2 (Two polinomial functions of 2nd order)

Analog Output transfer function can also be defined as a two polinomial function. Both polinomial are of 2nd order. So two different polinomial functions are used:

$$\text{Out} = [\pm A_0 + A_1(x') \pm A_2(x'^2)] + [\pm B_0 + B_1(x') \pm B_2(x'^2)]$$

Here the polinomial with A coefficients is used for X from 0 to a K value, and the second one with B coefficients for X greater than the K value.

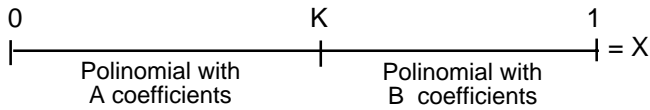

Ax and Bx terms of the polinomial have to be calculated according to the shape of the vessel.

A PC based software tool is available for polinomial coefficients definition.

4.0 CONSTANT CURRENT

This output function, activated by a Configuration Tool, can be used to test the transmitter output, the integrity of the transmission loop and the calibration of associated equipment like receivers, recorders, etc.

When this function is activated the transmitter acts like a constant current generator: using the configuration tool the user can specify a fixed output current of 4 mA, 20 mA or any value between 4 and 20 mA.

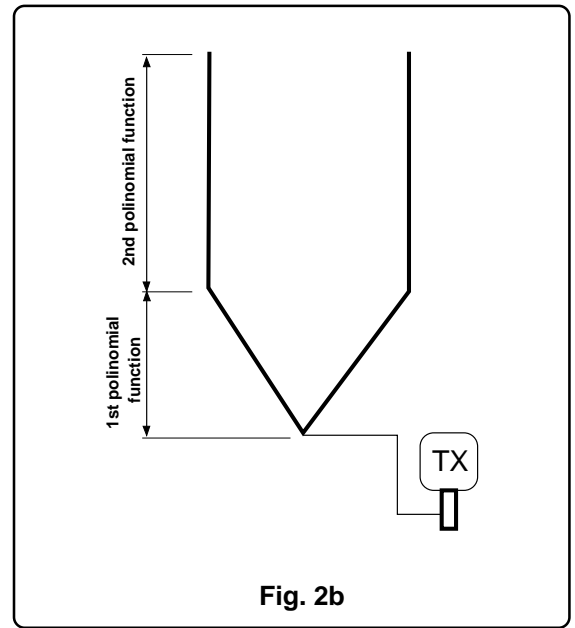

ADDENDUM FOR OUTPUT % RERANGING

Sometimes, in case of tank level measurement, it becomes difficult to calculate the LRV or the URV of the transmitter, or to empty the tank for zero adjustment. So, not only with flange-mounted, but also with differential pressure transmitters using remote seals, the Output % Reranging operation helps the user during transmitter calibration.

When it is known the level of the tank, expressed in percentage, the liquid level, it is possible to input this percentage that automatically the transmitter recalculates its LRV and URV according to the new percentage value.

This can be done using a HART configuration tool on a 2600T Transmitter, in Analog + HART version.

Two options are available as Output % Reranging operation:

- 1) OP Range Low where both LRV and URV are adjusted
- 2) OP Range High where only URV is change in accordance with the new input percentage

As example:

Actual level measured by the transmitter:

Transmitter output = 27%

Calibration : LRV = -125 mbar

URV = +340 mbar

a) New input level measurement (Option 1) = 30%

New calibration : LRV = -139.5 mbar

URV = +325.5 mbar

The transmitter output is now = 30%

Starting again from the initial settings:

Transmitter output = 27%

Calibration : LRV = -125 mbar

URV = +340 mbar

b) New input level measurement (Option 2) = 30%

New calibration : LRV = -125 mbar

URV = +291.5 mbar

The transmitter output is now = 30%

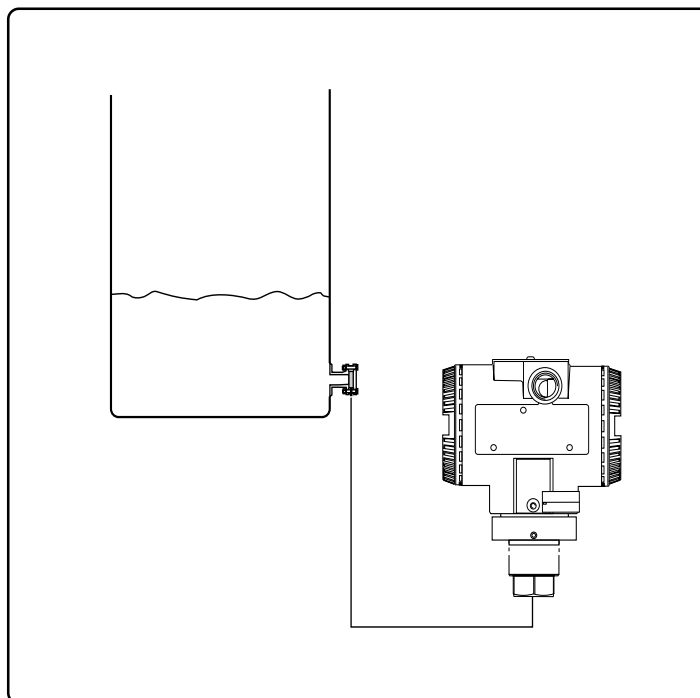

ADDENDUM FOR "EX SAFETY" ASPECTS AND "IP" PROTECTION (EUROPE)

According to ATEX Directive (European Directive 94/9/EC of 23 March 1994) and relative European Standards which can assure compliance with Essential Safety Requirements, i.e., EN 50014 (General requirements) EN 50018 (Flameproof enclosures "d") EN 50020 (Intrinsic safety "i") EN 50284 (Equipments, group II, category 1G) EN 50281 (Apparatus for use with combustible dusts), the pressure transmitters of the 2600T SERIES have been certified for the following group, categories, media of dangerous atmosphere, temperature classes, types of protection. Examples of application are also shown below by simple sketches.

- a) Certificate ATEX II 1G DT50°C, EEx ia IIC T6 (-40°C ≤ Ta ≤ +40°C)
respectively, DT95°C, EEx ia IIC T4 (-40°C ≤ Ta ≤ +85°C)

ZELM certificate number ZELM 02 ATEX 0081

The meaning of ATEX code is as follows:

II : Group for surface areas (not mines)

1 : Category

G : Gas (dangerous media)

D : Dust (dangerous media)

T50°C: Maximum surface temperature of the transmitter enclosure with a Ta (ambient temperature) +40°C for Dust (not Gas) with a dust layer up to 50 mm depth.

T95°C: As before for Dust for a Ta +85°C

(Note: the number close to the CE marking of the transmitter safety label identifies the Notified Body which has responsibility for the surveillance of the production)

The other marking refers to the protection type used according to relevant EN standards:

EEx ia : Intrinsic safety, protection level "a"

IIC : Gas group

T6 : Temperature class of the transmitter (which corresponds to 85°C max) with a Ta (ambient temperature) +40°C

T4 : Temperature class of the transmitter (which corresponds to 135°C max) with a Ta (ambient temperature) +85°C

About the applications, this transmitter can be used in "Zone 0" (Gas) and "Zone 20" (Dust) classified areas (continuous hazard) as it is shown on the following sketch:

Application with Gas

Zone "0"

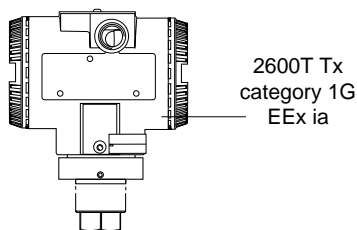

Note: the transmitter must be connected to a supply (associated apparatus) certified [EEx ia]

Application with Dust

Zone "20"

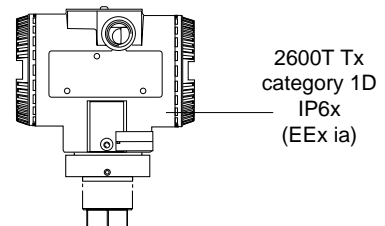

Note: the protection is mainly assured by the "IP degree" associated to the low power from the supply. This can either be [ia] or [ib]

ADDENDUM FOR "EX SAFETY" ASPECTS AND "IP" PROTECTION (EUROPE)

b) Certificate ATEX II 1/2 G DT50°C, EEx ia IIC T6 (-40°C ≤ Ta ≤ +40°C)
 respectively, DT95°C, EEx ia IIC T4 (-40°C ≤ Ta ≤ +85°C)

ZELM certificate number ZELM 02 ATEX 0081



Note: this ATEX **Category** depends on the application (see below) and also on the intrinsic safety level of the transmitter supply (associated apparatus) which can sometimes suitably be [ib] instead of [ia]. As it is well known, the level of an intrinsic safety system is determined by the lowest level of the various apparatus used, i.e., in the case of [ib] supply, the system takes over this level of protection.

The meaning of ATEX code is as follows:

- II : Group for surface areas (not mines)
 - 1/2 : Category - It means that only a part of the transmitter complies with category 1 and a second part complies with category 2 (see next application sketch)
 - G : Gas (dangerous media)
 - D : Dust (dangerous media)
 - T50°C: Maximum surface temperature of the transmitter enclosure with a Ta (ambient temperature) +40°C for Dust (not Gas) with a dust layer up to 50 mm depth.
 - T95°C: As before for Dust for a Ta +85°C
- (Note: the number close to the CE marking of the transmitter safety label identifies the Notified Body which has responsibility for the surveillance of the production)

The other marking refers to the protection type used according to relevant EN standards:

- EEx ia : Intrinsic safety, protection level "a"
- IIC : Gas group
- T6 : Temperature class of the transmitter (which corresponds to 85°C max) with a Ta (ambient temperature) +40°C
- T4 : Temperature class of the transmitter (which corresponds to 135°C max) with a Ta (ambient temperature) +85°C

About the applications, this transmitter can be used in Zone "0" (Gas) classified areas (continuous hazard) with its "process part" only, whereas the remaining part of the transmitter, i.e. its enclosure, can be used in Zone 1 (Gas), only (see sketch below). Reason of this is the process part of the transmitter (normally called primary transducer) that provides inside separation elements to seal off the electrical sensor from the continuously hazardous process, according to the EN50284 and EN50018. About Dust application, the transmitter is suitable for "Zone 21" according to the EN 50281 as it is shown on the relevant part of the sketch:

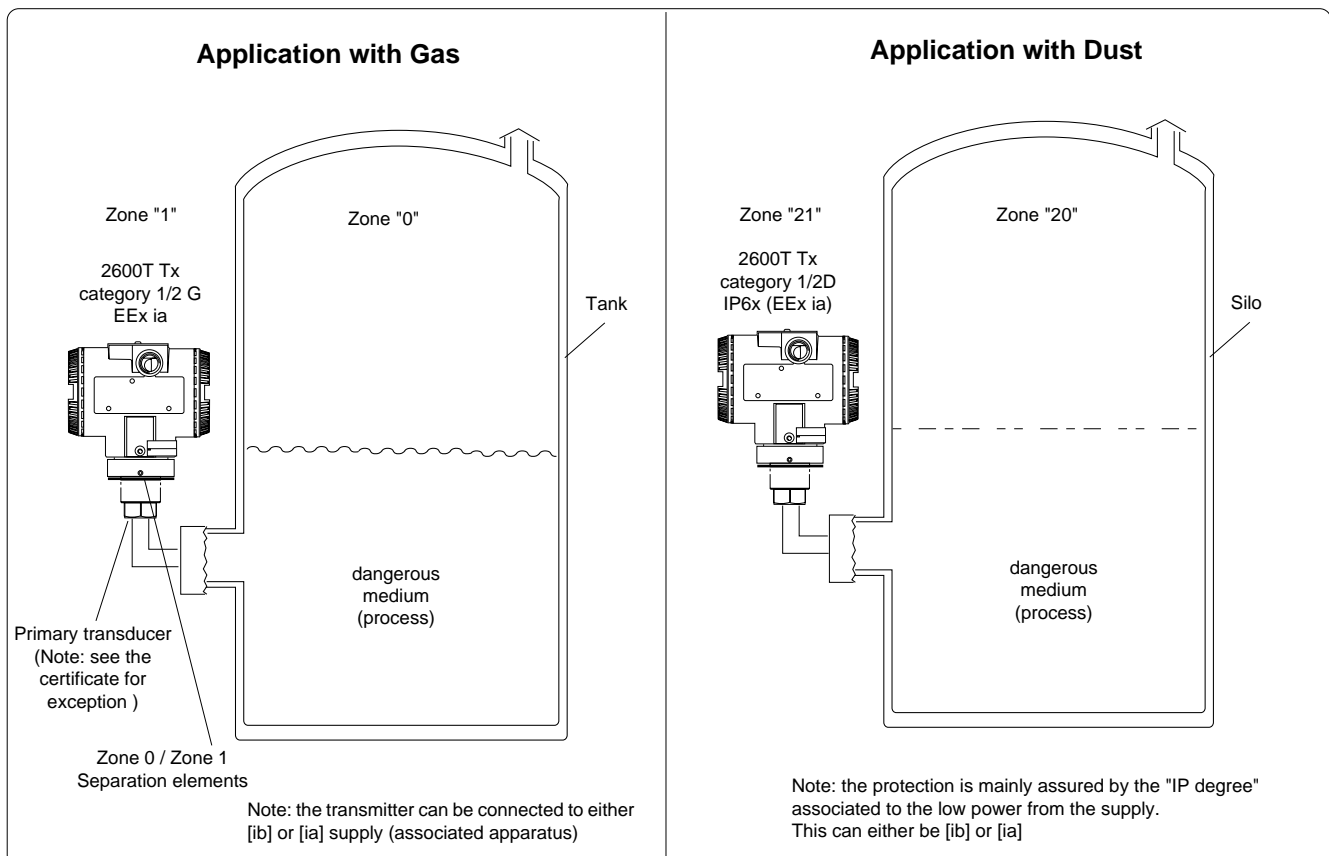

ADDENDUM FOR "EX SAFETY" ASPECTS AND "IP" PROTECTION (EUROPE)

c) Certificate ATEX II 1/2 GD, EEx d IIC T6
IP67 T85°C (-40°C ≤ Ta ≤ +75°C)

CESI Certificate number CESI 02ATEX 027

The meaning of ATEX code is as follows:

- II : Group for surface areas (not mines)
- 1/2 : Category - It means that only a part of the transmitter complies with category 1 and a second part complies with category 2 (see next application sketch)
- G : Gas (dangerous media)
- D : Dust (dangerous media)
- T85°C: Maximum surface temperature of the transmitter enclosure with a Ta (ambient temperature) +75°C for Dust (not Gas) with a dust layer up to 50 mm depth.

(Note: the number close to the CE marking of the transmitter safety label identifies the Notified Body which has responsibility for the Surveillance of the production)

The other marking refers to the protection type used according to relevant EN Standards:

- EEx d: Flameproof
- IIC : Gas group
- T6 : Temperature class of the transmitter (which corresponds to 85°C max) with a Ta (ambient temperature) +75°C.

About the applications, this transmitter can be used in Zone "0" (Gas) classified areas (continuous hazard) with its "process part" only, whereas the remaining part of the transmitter, i.e. its enclosure, can be used in Zone 1 (Gas), only (see sketch below). Reason of this is the process part of the transmitter (normally called primary transducer) that provides inside separation elements to seal off the electrical sensor from the continuously hazardous process, according to the EN50284 and EN50018. About Dust application, the transmitter is suitable for "Zone 21" according to the EN 50281 as it is shown on the relevant part of the sketch:

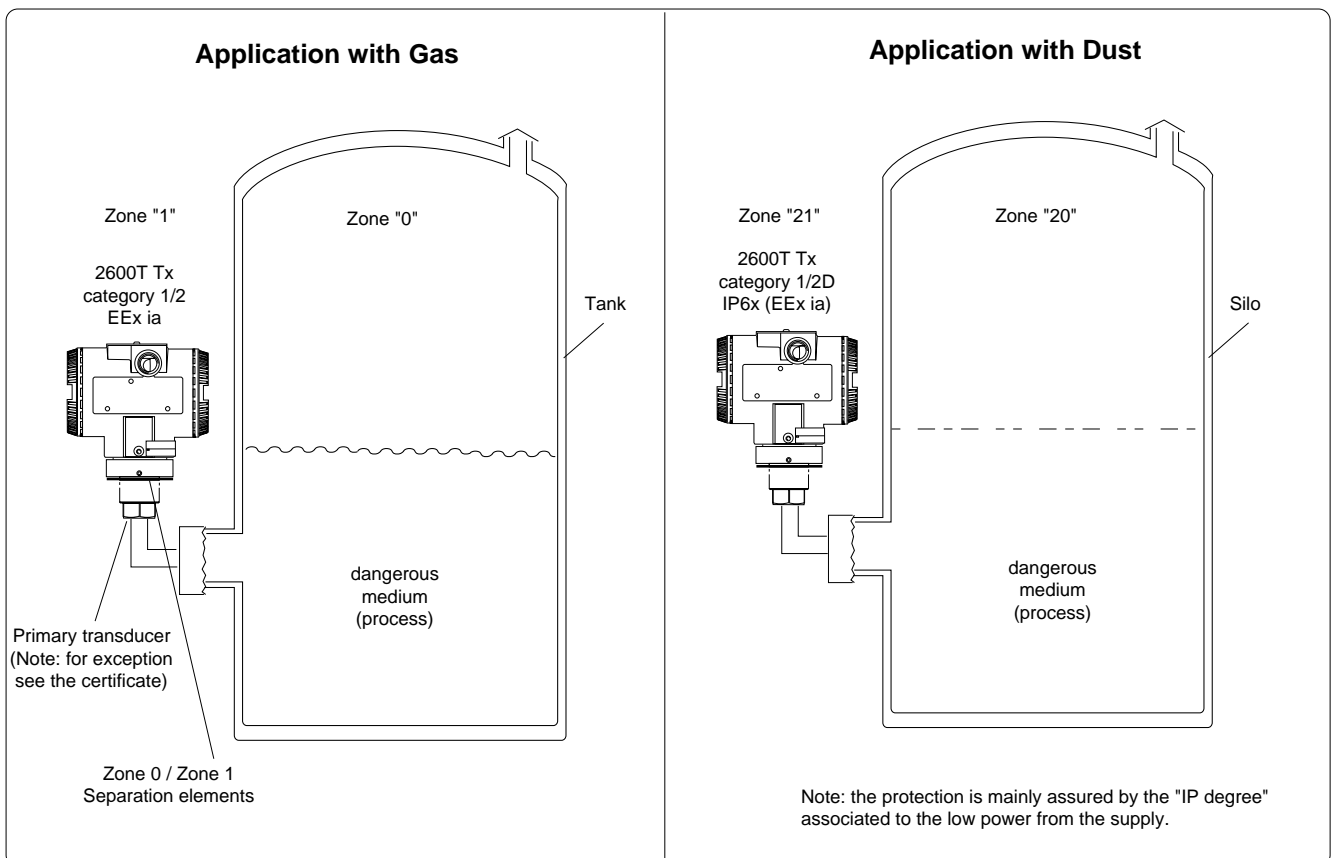

IP code

About the degree of protection provided by the enclosure of the pressure transmitter, the 2600T SERIES has been certified IP67 according to EN 60529 standard.

The first characteristic numeral indicates the protection of the inside electronics against ingress of solid foreign objects including dusts. The assigned "6" means an enclosure dust-tight (no ingress of dust).

The second characteristic numeral indicates the protection of the inside electronics against ingress of water. The assigned "7" means an enclosure water-protected against a temporary immersion in water under standardized conditions of pressure and time.

ADDENDUM FOR "EX SAFETY" ASPECTS (EUROPE)

According to ATEX Directive (European Directive 94/9/EC of 23 March 1994) and relative Standards which can assure compliance with Essential Safety Requirements, i.e., EN 50014 (General requirements) EN 50021 (Specification for electrical apparatus with type of protection "n") EN 50281 (Apparatus for use with combustible dusts), the pressure transmitters of the 2600T SERIES have been certified for the following group, categories, media of dangerous atmosphere, temperature classes, types of protection. Examples of application are also shown below by simple sketches.

d) Certificate ATEX II 3G DT50°C, EEx nL IIC T6 ($-40^{\circ}\text{C} \leq T_a \leq +40^{\circ}\text{C}$)
respectively, DT95°C, EEx nL IIC T4 ($-40^{\circ}\text{C} \leq T_a \leq +85^{\circ}\text{C}$)

ZELM "Conformity Statement" number ZELM 02 ATEX 3088

(Note: It is the technical support for the ABB Declaration of Conformity)

The meaning of ATEX code is as follows:

II : Group for surface areas (not mines)

3 : Category

G : Gas (dangerous media)

D : Dust (dangerous media)

T50°C: Maximum surface temperature of the transmitter enclosure with a T_a (ambient temperature) $+40^{\circ}\text{C}$ for Dust (not Gas) with a dust layer up to 50 mm depth.

T95°C: As before for Dust for a $T_a +85^{\circ}\text{C}$

The other marking refers to the protection type used according to the standards:

EEx nL : Type of protection "n" with "energy limitation" technique

IIC : Gas group

T6 : Temperature class of the transmitter (which corresponds to 85°C max) with a T_a (ambient temperature) $+40^{\circ}\text{C}$

T4 : Temperature class of the transmitter (which corresponds to 135°C max) with a T_a (ambient temperature) $+85^{\circ}\text{C}$



Note: when installed this transmitter must be supplied by a voltage limiting device which will prevent the rated voltage of 42 V d.c. being exceeded.

About the applications, this transmitter can be used in "Zone 2" (Gas) and "Zone 22" (Dust) classified areas (unlikely/infrequent hazard) as it is shown on the following sketch:

Application with Gas

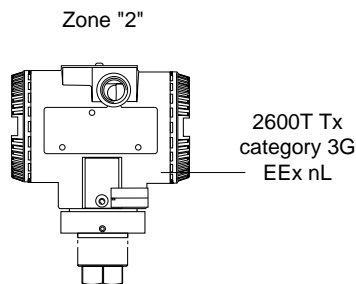

Note: the transmitter must be connected to a supply with 42 V d.c. max output voltage as above indicated. The Ii of the transmitter is less than 25 mA.

Application with Dust

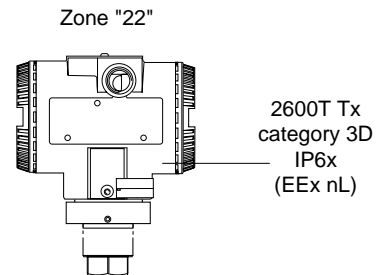

Note: the protection is mainly assured by the "IP degree" associated to the low power from the supply.



Prüf- und Zertifizierungsstelle

ZELM Ex



(1) **EC-TYPE-EXAMINATION CERTIFICATE**
(Translation)

(2) Equipment and Protective Systems Intended for Use in
Potentially Explosive Atmospheres - **Directive 94/9/EC**

(3) EC-TYPE-EXAMINATION CERTIFICATE Number:

ZELM 02 ATEX 0081

(4) Equipment: **2600T Series Pressure Transmitters, HART 4...20 mA**

(5) Manufacturer: **ABB Instrumentation spa**

(6) Address: **Via Statale 113, 22016 Lenno (Como), Italy**

(7) This equipment and any acceptable variation thereto are specified in the schedule to this certificate and the documents therein referred to.

(8) The Prüf- und Zertifizierungsstelle ZELM Ex, notified body No. 0820 in accordance with Article 9 of the Council Directive 94/9/EC of 23 March 1994, certifies that this equipment has been found to comply with the Essential Health and Safety Requirements relating to the design and construction of equipment and protective systems intended for use in potentially explosive atmospheres, given in Annex II to the Directive.

The examination and test results are recorded in the confidential report ZELM Ex 0360117114.

(9) Compliance with the Essential Health and Safety Requirements has been assured by compliance with:

EN 50 014: 1997+A1+A2
EN 50 281-1-1: 1998

EN 50 020: 1994
EN 1127-1: 1997

EN 50 284: 1999

(10) If the sign "X" is placed after the certificate number, it indicates that the equipment is subject to special conditions for safe use specified in the schedule to this certificate.

(11) This EC-type-examination Certificate relates only to the design, examination and tests of the specified equipment or protective system in accordance to the Directive 94/9/EC. Further requirements of the Directive apply to the manufacturing process and supply of this equipment or protective system. These are not covered by this Certificate.

(12) The marking of the equipment shall include the following:



II 1 GD T 50°C EEx ia IIC T6 resp. II 1 GD T 95°C EEx ia IIC T4

or

II 1/2 GD T 50°C EEx ia IIC T6 resp. II 1/2 GD T 95°C EEx ia IIC T4

Zertifizierungsstelle ZELM Ex

Dipl.-Ing. Harald Zelm



Braunschweig, April 25, 2002

Sheet 1/3

EC-type-examination Certificates without signature and stamp are not valid. The certificates may only be circulated without alteration. Extracts or alterations are subject to approval by the Prüf- und Zertifizierungsstelle ZELM Ex. In the case of dispute, the German text shall prevail.

Prüf- und Zertifizierungsstelle ZELM Ex • Siekgraben 56 • D-38124 Braunschweig



Prüf- und Zertifizierungsstelle

ZELM Ex



SCHEDULE

(13)

(14) **EC-TYPE-EXAMINATION CERTIFICATE ZELM 02 ATEX 0081**

(15) Description of equipment

The 2600T series Pressure Transmitters is used for measurement and conversion of the physical quantities pressure above atmospheric and differential pressure absolute pressure into an analogous electrical standard signal of a 4 ... 20 mA current loop and digital communication according to the HART protocol in the hazardous area.

The attached pressure works on the ceramic measuring sensor or the silicon measuring sensor.

The Pressure Transmitter is mounted into a housing meeting the degree of protection \geq IP 65 according to EN 60529:1991 – for dust including the cable entry fittings.

The Pressure Transmitter is allowed to be directly installed into the hazardous area of category 1G resp. 1D or into the separation wall between the hazardous areas of category 1G or 1D and category 2G or 2D.

The operating conditions for service with flammable measuring mixtures – which are non-explosive - and higher pressures are to be taken from the instruction manual and operation manual respectively.

The Pressure Transmitter may optionally be fitted with digital or analogue meters for which a separate EC-type Examination Certificate has been issued.

The maximum permissible ambient temperature is -40 °C to $+85\text{ °C}$.

The model code will be:

type 262.. / 264..

Instead of the points of the model code other letter- or numeral- combinations will be stated, which are describing several variations and versions of the equipment.

Electrical data

Supply and signal circuit (terminals signal +,-)

type of protection Intrinsic Safety EEx ib IIC or EEx ia IIC
for connection to supply units with intrinsically safe circuits "ia" and II 1 GD T 50°C EEx ia IIC T6 resp. II 1 GD T 95°C EEx ia IIC T4
or
for connection to supply units with intrinsically safe circuits "ib" or "ia" and II 1/2 GD T 50°C EEx ib or ia IIC T6 respectively
II 1/2 GD T 95°C EEx ib or ia IIC T4

maximum values:

$$U_i = 30 \text{ V}$$

Temperature class	lower limit of ambient temperature	upper limit of ambient temperature	max. I_i [mA]	max. P_i [W]
T4 resp. T 95 °C	- 40 °C	+ 85 °C	100	0,75
T4 resp. T 95 °C	- 40 °C	+ 70 °C	160	1
T5 resp. T 95 °C	- 40 °C	+ 40 °C	100	0,75
T6 resp. T 50 °C	- 40 °C	+ 40 °C	50	0,4

Sheet 2/3

EC-type-examination Certificates without signature and stamp are not valid. The certificates may only be circulated without alteration. Extracts or alterations are subject to approval by the Prüf- und Zertifizierungsstelle ZELM Ex. In the case of dispute, the German text shall prevail.

Prüf- und Zertifizierungsstelle ZELM Ex • Siekgraben 56 • D-38124 Braunschweig



Prüf- und Zertifizierungsstelle

ZELM Ex



Schedule to EC-TYPE-EXAMINATION CERTIFICATE_ZELM 02 ATEX 0081

effective internal capacitance is negligibly small
resp. $C_i = 13 \text{ nF}$ with output meter
effective internal inductance is negligibly small
resp. $L_i = 0,22 \text{ mH}$ with output meter

Degree of protection at least IP 65 according to EN 60529:1991

References:

The instruction manual has to be considered, in particular the maximum thickness of dust layers permitted for the hazardous area of category 1D and the sufficient equipotential bonding and grounding and the overvoltage protection.

For the use in dust atmosphere the degree of protection \geq IP 65 must be ensured in regard to the enclosure and the cable entry fitting.

Having the capacitive measuring element type 26.A. or 26.G. ($\leq 400 \text{ mbar}$) and a supply with an intrinsically safe circuit EEx ib IIC the use is not permitted for category 1GD or 1/2 GD respectively.

(16) Report No.

ZELM Ex 0360117114

(17) Special conditions for safe use

not applicable

(18) Essential Health and Safety Requirements

met by standards

Zertifizierungsstelle ZELM Ex

Dipl.-Ing. Harald Zelm



Braunschweig, April 25, 2002

Sheet 3/3

EC-type-examination Certificates without signature and stamp are not valid. The certificates may only be circulated without alteration. Extracts or alterations are subject to approval by the Prüf- und Zertifizierungsstelle ZELM Ex. In the case of dispute, the German text shall prevail.

Prüf- und Zertifizierungsstelle ZELM Ex • Siekgraben 56 • D-38124 Braunschweig

PRODUCTS & CUSTOMER SUPPORT

A Comprehensive Instrumentation Range

Analytical Instrumentation

- **Transmitters**
On-line pH, conductivity, and dissolved oxygen transmitters and associated sensing systems.
- **Sensors**
pH, redox, selective ion, conductivity and dissolved oxygen.
- **Laboratory Instrumentation**
pH and dissolved oxygen meters and associated sensors.
- **Water Analyzers**
For water quality monitoring in environmental, power generation and general industrial applications including: pH, conductivity, ammonia, nitrate, phosphate, silica, sodium, chloride, fluoride, dissolved oxygen and hydrazine.
- **Gas Analyzers**
Zirconia, katharometers, hydrogen purity and purge-gas monitors, thermal conductivity.

Controllers & Recorders

- **Controllers**
Digital display, electronic, pneumatic. Discrete single-loop and multi-loop controllers which can be linked to a common display station, process computer or personal computer.
- **Recorders**
Circular and strip-chart types (single and multi-point) for temperature, pressure, flow and many other process measurements.

Electronic Transmitters

- **Smart & Analog Transmitters**
For draft, differential, gauge and absolute pressure measurement. Also, liquid level and temperature.
- **I to P Converters and Field Indicators**

Flow Metering

- **Magnetic Flowmeters**
Electromagnetic, insertion type probes and watermeters.
- **Turbine Flowmeters**
- **Wedge Flow Elements**
- **Mass Flow Meters**
Transmitters, sensors, controllers and batch/display units.

Level Control

- **Submersible, Capacitance & Conductivity.**

Pneumatic Instrumentation

- **Transmitters**
- **Indicating Controllers**
- **Recording Controllers**

Customer Support

ABB Instrumentation provides a comprehensive after sales service via a Worldwide Service Organization. Contact one of the following offices for details on your nearest Service and Repair Centre.

Italy

ABB Instrumentation SpA
Tel: +39 (0) 344 58111
Fax: +39 (0) 344 58278

United Kingdom

ABB Automation Limited
Tel: +44 (0)1480 475321
Fax: +44 (0)1480 470787

United States of America

ABB Automation Inc.
Instrumentation Division
Tel: +1 215-674-6000
Fax: +1 215-674-7183

Client Warranty

Prior to installation, the equipment referred to in this manual must be stored in a clean, dry environment, in accordance with the Company's published specification. Periodic checks must be made on the equipment's condition.

In the event of a failure under warranty, the following documentation must be provided as substantiation:

1. A listing evidencing process operation and alarm logs at time of failure.
2. Copies of operating and maintenance records relating to the alleged faulty unit.



CE-Declaration of Conformity
(Directive 94/9/EC, Annex II and VIII)

We ABB Instrumentation spa
 Via Statale 113
 22016 Lenno (Como)
 Italy

declare under our sole responsibility that models 262, 264 of the

2600TSERIES Pressure Transmitters

to which this declaration relates are in conformity with following standards

EN 50021: 1999 (or IEC 60079-15 : 2001)
EN 50281-1-1: 1999

Lenno, 1st July 2002

Andrea Moroni
Technical Director

ABB Instrumentation spa

Automation

Sede legale:
20137 Milano - P.le Lodi, 3
Capitale L.7.188.000.000 i.v.
Reg. Imp. n. 36394/1368/1747 Trib. MI
R.E.A. MI 247921 - R.E.A. CO 56797
Codice Fiscale/Iva 00738060151

Sede Amministrativa/Commerciale Estero:
Via Statale, 113 - 22016 Lenno (Co) Italy
Tel. +39 0344 58111 - Fax +39 0344 56278
Sede Commerciale Italia:
Via Sempione, 243 - 20016 Pero (MI) Italy
Tel. +39 02 339281 - Fax +39 02 33928467

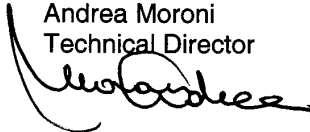
Hartmann & Braun



EC DECLARATION OF CONFORMITY

We: ABB Instrumentation S.p.A.
Via Statale, 113
22016 Lenno (Como)
Italy

declares under our sole responsibility that the products:

2600T Series (Transmitter models 262/264/266/268 in the communication configurations 4-20 mA + HART® and Safety)

are in conformity with the following standards:

EN 61000-6-3 (2001) Electromagnetic compatibility (EMC) -
Generic standards - Emission standard for
residential, commercial and light-industrial
environments

according to: EN55022 (2001)

EN 61000-6-2 (2001) Electromagnetic compatibility (EMC) -
Generic standards - Immunity for industrial
environments

*according to: EN 61000-4-2 (2001)
EN 61000-4-3 (2002)
EN 61000-4-4 (2001)
EN 61000-4-5 (2001)
EN 61000-4-6 (2001)*

following the provisions of the EMC Directives 89/336/EEC and
93/68/EEC.

Lenno, July 22, 2002

ABB Instrumentation S.p.A.
Technical Manager
A. Moroni

ABB Instrumentation spa



ABB Ltd.
Howard Road, St. Neots
Cambs. England PE19 3EU
Tel. +44 01480 475321
Facsimile +44 01480 217948

ABB Inc.
125 East County Line Road
Warminster, Pa. 18974 USA
Tel. +1 215 674-6000
Facsimile +1 215 674-7183

ABB Instrumentation spa
Via Statale, 113
22016 Lenno (CO) Italia
Tel. +39 (0344) 58111
Facsimile +39 (0344) 56278

The Company's policy is one of continuous product improvement and the right is reserved to modify the specifications contained herein without notice.