

Specification DataFile

- **PID controller with multiple control strategies**
 - single loop, heat/cool, motorized valve, auto/manual, analog backup or indicator
- **Three large LED displays with deviation bargraph**
 - clear and easy to follow display with color-coordinated function keys
- **Comprehensive input/output capabilities**
 - three analog inputs, two analog outputs, up to four relays and four digital inputs plus RS485 MODBUS for total flexibility
- **Process security and plant safety**
 - loop break alarm, processor watchdog, password protection and intelligent power recovery
- **PC configuration for ease of setup**
 - access to advanced feature and standard settings to reduce configuration time
- **Advanced cost-saving functions**
 - math blocks, logic equations, real-time alarms, custom linearizers and soft wiring
- **Unique Control Efficiency Monitor (CEM)**
 - two autotune algorithms plus manual fine-tune using CEM for optimum performance
- **IP66/NEMA4X front face protection**
 - reliability in the harshest environments



*COMMANDER 351 – short case
1/4 DIN controller with additional
functionality and power as
standard*

COMMANDER 351

The **COMMANDER 351** Universal Process controller is a versatile, **single loop controller**, with multiple control features built-in as standard, e.g. gain scheduling, heat/cool, alarm logic, maths and linearizers.

With the ability to configure for different applications, using the inbuilt library of **application templates**, plus the advanced autotune facility, the C351 is ready to run in minutes. Configurations can also be edited and stored off-line using our Windows-based **PC Configurator software**.

Analog, relay and logic control outputs are fitted as standard; plus three analog inputs, with a built-in **2-wire transmitter power supply**. With the option to add extra input/outputs, for more complex applications, and **MODBUS** serial communications for integration with factory automation systems.

IP66 (NEMA4X) front panel protection makes the COMMANDER 351 an extremely robust controller, suitable for use in a wide variety of industrial environments.



Process Connections

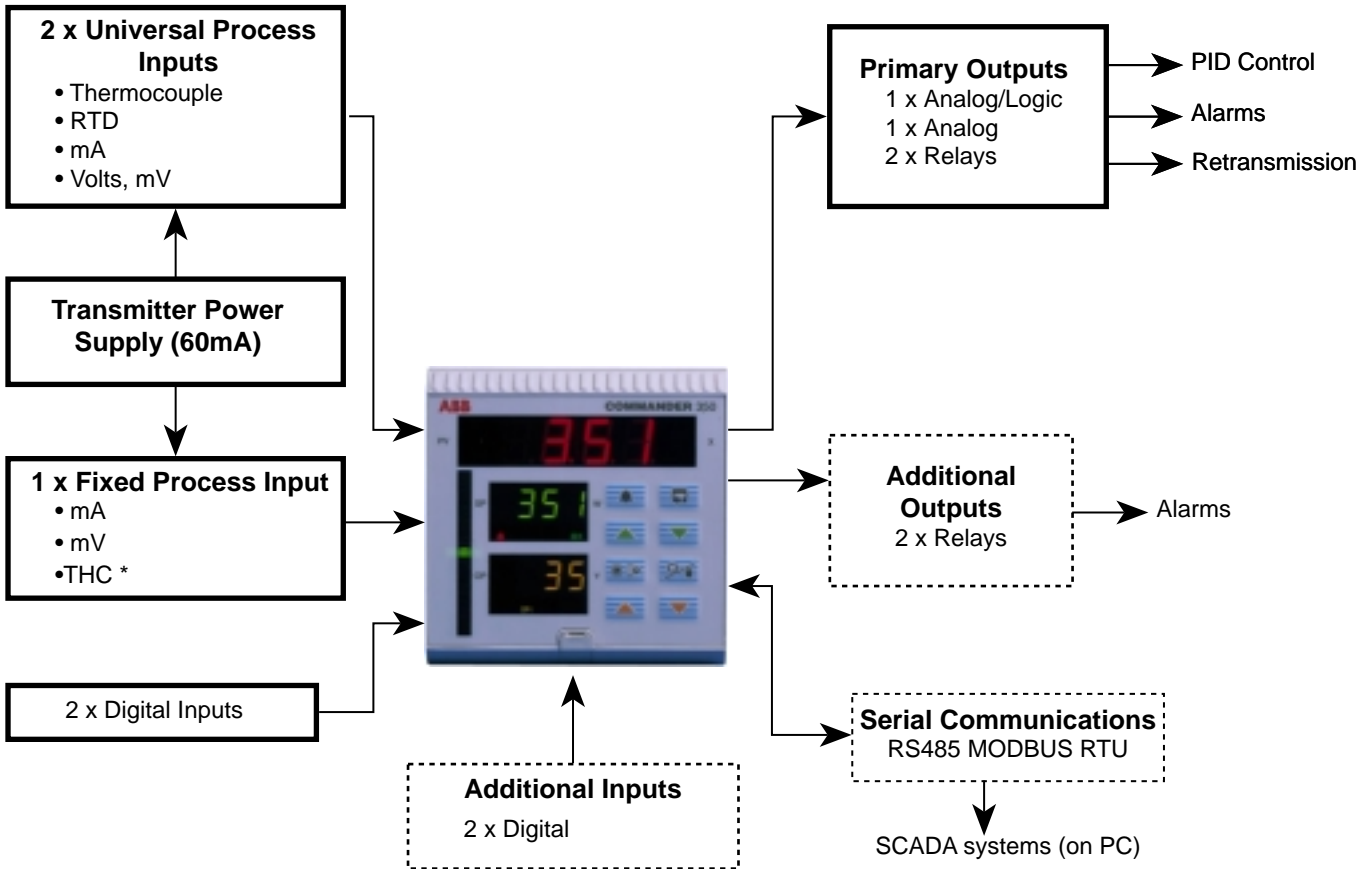

KEY: Standard Option

* Only if standard universal input is THC

Protecting Your Process

To keep your process stable and secure, the COMMANDER 351 has intelligent diagnostics and responses which can be used for process safety to initiate an action or to indicate a fault. A processor watchdog monitors the processor continuously; a unique loop-break alarm detects analog output failure; and there is an open circuit detector on the input. Using these signals, safety shutdown strategies can be initiated.

Advanced control features, including ramping set point, process start-up and output slew-rate, are all designed to provide you with a flexible controller that has built-in process protection as standard.

For configuration data security, there are three levels of password protection plus front panel function key lockouts, ensuring total process security.

Process Visibility and Operation

Three high-visibility, colored, digital displays Indicate Process Variable, Set Point and Controller output simultaneously.

A 21-segment deviation bargraph shows at-a-glance how close the controller is to the set point. For clarity, function keys are color coded to match their corresponding displays.

Eight individual tactile front panel keys make the controller very operator-friendly, with one-touch access to local/remote set point adjustment, alarm acknowledgment, auto/manual and output adjustment.

'Secret-til-lit' LED indicators display controller modes and alarm status, and provide extensive controller and plant diagnostics.

Maths and Soft-Wiring

Four individual math blocks, each having up to seven operators and operands, provide functions such as average, maximum and minimum calculations. Square root, relative humidity and arithmetic functions are also included as standard. Inputs can be selected or switched in and out of calculations by digital signals. This allows both simple and advanced calculations to be processed and these can be soft-wired to control functions.

Control Efficiency Monitor (CEM)

CEM measurements are designed to help you fine-tune your process manually. Six key-performance parameters are measured and displayed, allowing you to vary your PID settings to match the process needs and measure the results of your investment.

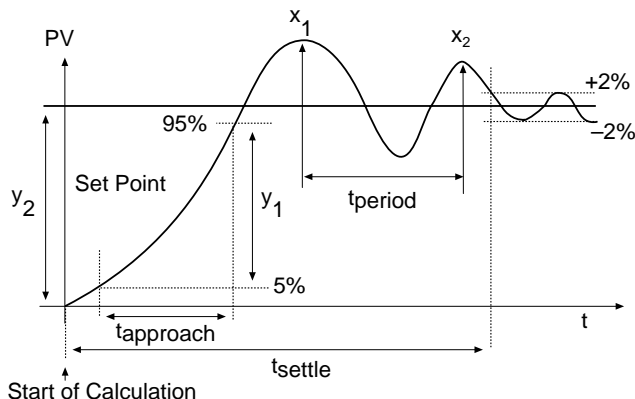

Process Alarms

The COMMANDER 351 has eight internal process alarms. These can be soft-wired to control strategies, logic equations and output relays.

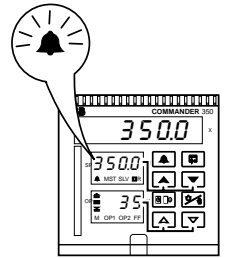

Each alarm can have a separate hysteresis value, programmable in engineering units or time. Alarms can also be enabled or disabled via digital inputs and can be configured as annunciators, so the alarm may be disabled once acknowledged.

Configuration and Start Up Made Easy

The COMMANDER 351 has been designed to minimize your configuration and commissioning time, as you need only enter values that relate to your process. Application templates, offering preconfigured customized control strategies, allow rapid setup of the controller. Templates are selected via the PC Configurator or the front panel keys. Alternatively the unit may be supplied preconfigured. Once a template is selected only **three key settings** are required and the **controller is ready-to-run**.

Complete configurations can be created, edited and stored off-line, using the COMMANDER PC Configurator. A dedicated cable connects the PC to a jack socket on the top of the controller for rapid upload, or download, of configurations. Copies of the configurations can be saved and produced as hard copy.

A dual mode, intelligent autotune requires no prior knowledge of PID settings and offers a choice of either fast response or minimum overshoot strategies.

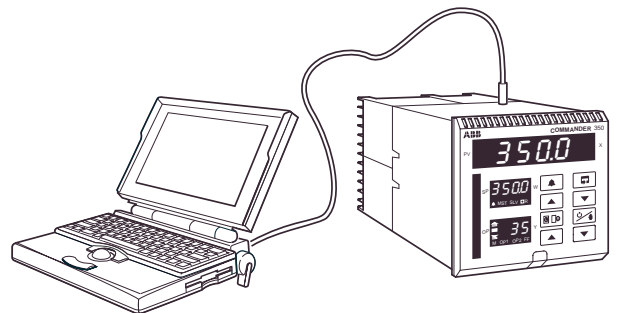

Custom Linearizer

The COMMANDER 351 has two separate 15-breakpoint linearizers which can be programmed via the PC Configurator and applied to either inputs or outputs. These can be used for nonstandard thermocouples, nonlinear tank levels or any nonlinear input. The output linearizer accommodates any nonlinear control elements.

Customized Application Templates

Templates are provided to make the basic configuration for a particular application as simple as possible. When a template is selected the COMMANDER 351 assumes the preset form for that template (see below). The inputs and software blocks are soft-wired automatically to perform the selected function.

Configuration time is greatly reduced as 90% of the choices you would normally need to make in similar products are already preconfigured.

The COMMANDER 351 offers the following templates:

- 1 Single loop controller with local set point
- 2 Single loop controller with remote set point
- 3 Auto manual station (low signal detection)
- 4 Auto manual station (digital signal selection)
- 5 Analog backup station (low signal detection)
- 6 Analog backup station (digital signal selection)
- 7 Single indicator/manual loader station
- 8 Dual indicator/manual loader station

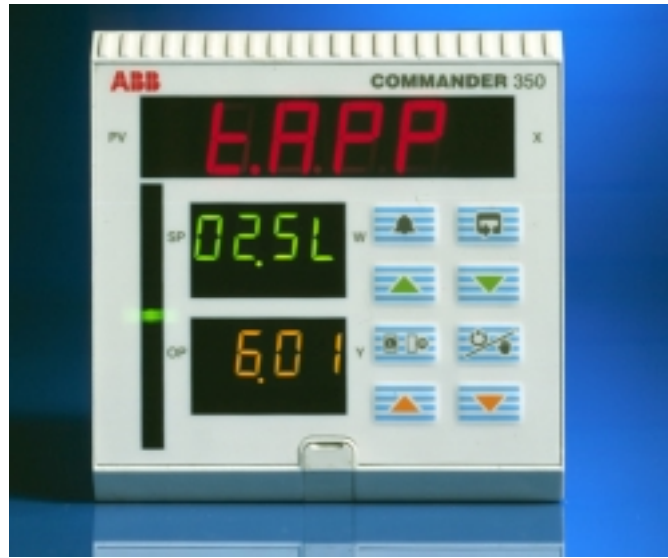

Single Loop Control Template – Example

A single element drum level is used in industrial boiler applications where steam demand changes slowly and/or constant BTU content fuel-fired boilers.

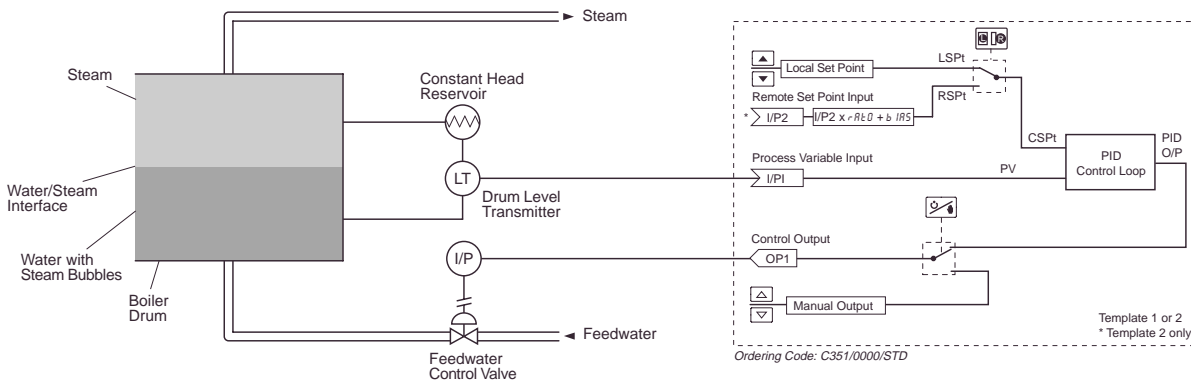

Sequencing and Logic Control

The COMMANDER 351 offers comprehensive sequencing, to complement its advanced analog control features, six logic equations, with up to fifteen elements per equation. These logic equations, when combined with delay timers, real-time alarms and extensive I/O, make the COMMANDER 351 a powerful interlocking controller.

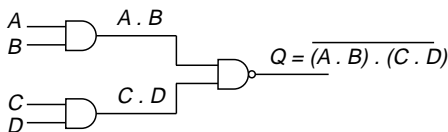

Intelligent Adjustable Power Recovery

Two forms of plant power failure recovery are available programmable between 0 and 9999s for recovery time:

'HOT' Restart – if the power is restored within the recovery time the COMMANDER 351 defaults to Auto mode, allowing the process to be up-and-running without delay.

'COLD' Restart – if the power is not restored within the preset recovery time, the controller defaults to Manual mode, or a predetermined control output level. This ensures that after power failure the controller does not start to control the process without operator acknowledgment.

Industrial Robust Design

The front face has been designed to meet IP66/NEMA4X rating with a unique moulded case and panel seal. A chemical resistant polyester front panel ensures a secure investment for any environment.

Specification

Summary

- 8 application templates: Single loop, Auto/Manual, Analog backup, Indicator
- Two Autotune options
- Control Efficiency Monitor (CEM)
- PC configuration
- IP66/NEMA4X front face

Operation

Display

- 1 x 4-digit, 14 mm (Red) LED – process variable
- 1 x 4-digit 8 mm (Green) LED – set point
- 1 x 3-digit, 8 mm (Yellow) LED – output
- 1 x 21-segment deviation bargraph

Configuration

- Basic configuration via front panel keys or PC
- Advanced feature configuration by PC

Security

- Password-protected menus

Standard Functions

Control Strategies

- Single-loop, Auto/manual Station, Analog Backup, Indicator/Manual Loader

Output Types

- Current proportioning, Time proportioning, On/off, Motorized valve (with and without feedback), Heat/cool.

Control Parameters

- Four sets of PI settings, selectable via digital signals

Set Points

- Local, remote and four local fixed set points, selectable via digital signals

Configured Outputs

- Three preset output values, selectable via digital signals

Autotune

- On demand for $1/4$ wave or minimal overshoot

Process Alarms

Number	8
Types	High/low process, High/low output, High/low deviation
Hysteresis	Level and time *
Alarm enable/disable	Enable/disable of alarms via digital signal

Real Time Alarms *

Number	2
Programmable	On time/day and duration

* Accessed via PC Configurator

Analog Inputs

Universal Process Inputs

Number

2 standard

Type

Universally configurable to provide:
Thermocouple (THC)
Resistance thermometer (RTD)
mV
Volts
mA
Resistance

Non-universal Process Input

Number

1 standard

Types

mV only (THC only if I/P1 is also THC)
mA

Analog Inputs – Common

Linearizer Functions

THC types B, E, J, K, L, N, R, S, T, PT100, $\sqrt{\quad}$, $3/2$, $5/2$

Input Impedance

mA	100 Ω
mV, V	10M Ω

Broken Sensor Protection

Programmable for upscale or downscale drive

Sample Interval

125ms (1 input)

Digital filter

Programmable

Cold Junction Compensation

Automatic CJC incorporated as standard
Stability 0.05°C/°C (0.05°F/°F) change in ambient temperature

Input Protection

Common mode rejection	>120dB at 50/60Hz with 300 Ω imbalance resistance
Series mode rejection	> 60dB at 50/60Hz

Transmitter Power Supply

Voltage:	24Vd.c. nominal
Drive:	Up to 60mA, (3 loops)

EMC

Emissions

Meets requirements of EN50081-2

Immunity

Meets requirements of EN50082-2

Outputs

Control/Retransmission Outputs

Number	2 standard
Type	1 x programmable as analog or logic (digital) output 1 x analog only
Isolation	Galvanically isolated from the rest of the circuitry
Analog range	0 and 20mA (programmable), max. 750Ω accuracy: 0.25%
Digital voltage	17V @ 20mA

Relay Outputs

Number	2 standard,
Type	SPCO, rated 5A at 115/230V a.c.

Digital Inputs

Number	2 standard,
Type	Volt-free
Minimum pulse	200ms

Advanced Features

Maths Blocks *

Number	4
Operators	+, -, x, ÷, Average, Maximum, Minimum, High select, Low select, √, Median select, Relative Humidity Input multiplexer (digitally selected)

Delay Timers *

Number	2
Programmable Delay and Duration in seconds	

Logic Equations *

Number	6
Elements	15 per equation
Operators	OR, AND, NOR, NAND, NOT, EXOR

Custom Linearizers *

Number	2
Breakpoints	15 per linearizer

* Accessed via PC Configurator

Options

Relay Outputs

Number	2
Type	SPST, rated 5A at 115/230V a.c.

Digital Inputs

Number	2
Type	Volt-free
Minimum pulse	200ms

Serial Communications

Connections	RS485, 2- or 4-wire
Protocol	MODBUS RTU
Isolation	Galvanically isolated from the rest of the circuitry

Standard Analog Input Ranges

Thermocouple	Maximum Range °C	Maximum Range °F	Accuracy (% of reading)
B	-18 to 1800	0 to 3270	0.1% or ±1°C (1.8°F) [above 200°C (392°F)]
E	-100 to 900	-140 to 1650	0.1% or ±0.5°C (0.9°F)
J	-100 to 900	-140 to 1650	0.1% or ±0.5°C (0.9°F)
K	-100 to 1300	-140 to 2350	0.1% or ±0.5°C (0.9°F)
L	-100 to 900	-140 to 1650	0.1% or ±1.5°C (2.7°F)
N	-200 to 1300	-325 to 2350	0.1% or ±0.5°C (0.9°F)
R	-18 to 1700	0 to 3000	0.1% or ±0.5°C (0.9°F) [above 300°C (540°F)]
S	-18 to 1700	0 to 3000	0.1% or ±0.5°C (0.9°F) [above 200°C(392°F)]
T	-250 to 300	-400 to 550	0.1% or ±0.5°C (0.9°F)

RTD	Maximum Range °C	Maximum Range °F	Accuracy (% of reading)
PT100	-200 to 600	-325 to 1100	0.1% or ±0.5°C (0.9°F)

Linear Inputs	Range	Accuracy (% of reading)
Millivolts	0 to 500 mV	0.1% or ±10μA
Milliamps	0 to 50 mA	0.2% or ±2μA
Volts	0 to 5V	0.2% or ±2mV
Resistance	0 to 5000Ω	0.2% or ±0.08Ω

Notes.

Performance accuracy is not guaranteed at extreme low end of thermocouple and sq. root ranges.
RTD, 3-wire platinum, 100Ω per DIN 43760 standard (IEC751), with range of 0 to 400Ω.

Min. span below zero

THC standards
RTD standards

Type T 70°C/126°F
Type N 105°C/189°F
DIN 43710 IEC 584
DIN 43760 IEC 751

Physical

Size

96 x 96 x 122.5mm (3.78 in. x 3.78 in. x 4.82 in.)

Weight

680g (1.5lb)

Electrical

Voltage

85 to 265V a.c. 50/60Hz
24V d.c.

Power consumption

<10VA

Power interruption protection

Up to 60ms

Safety

General safety EN 61010-1

Isolation

All inputs/outputs to earth: 500V d.c.
Analog/digital output 1 to rest of the circuitry:
500V d.c. for 1 minute
Analog output 2 to rest of the circuitry:
500V d.c. for 1 minute
Serial communications to rest of the circuitry:
500V d.c. for 1 minute

Environmental

Operating Limits

0°C to 55°C (32°F to 130°F)
5 to 95%RH (non-condensing)

Temperature stability

<0.02%/°C or 2μV/°C (<0.011%/°F or 1.11μV/°F)
Long term drift <0.02% of reading or 20μV annually

Front face

NEMA4X (IP66)

Overall Dimensions

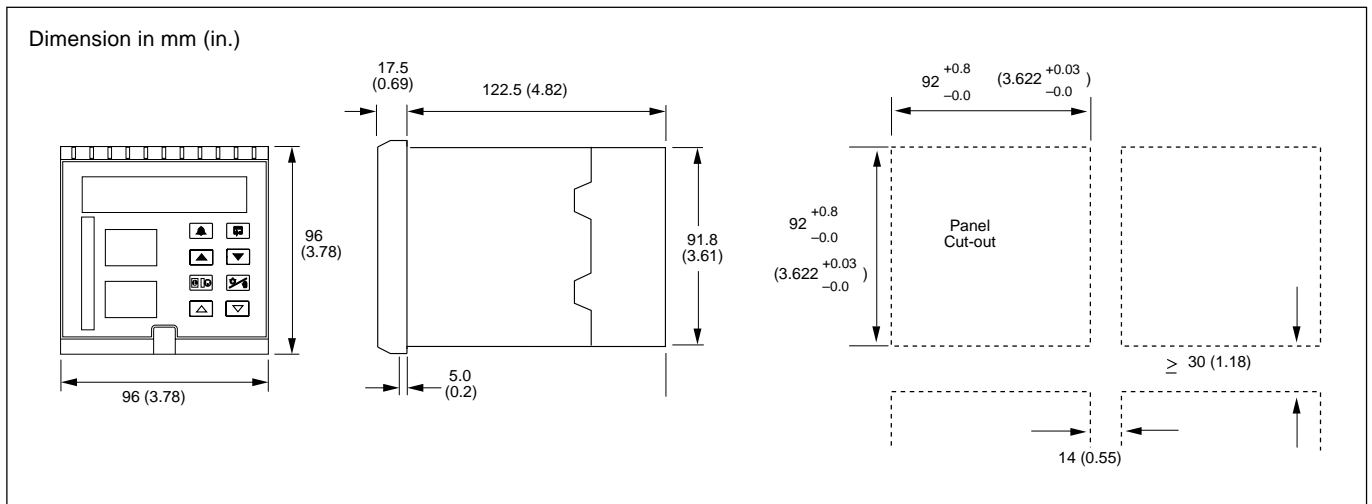

Electrical Connections

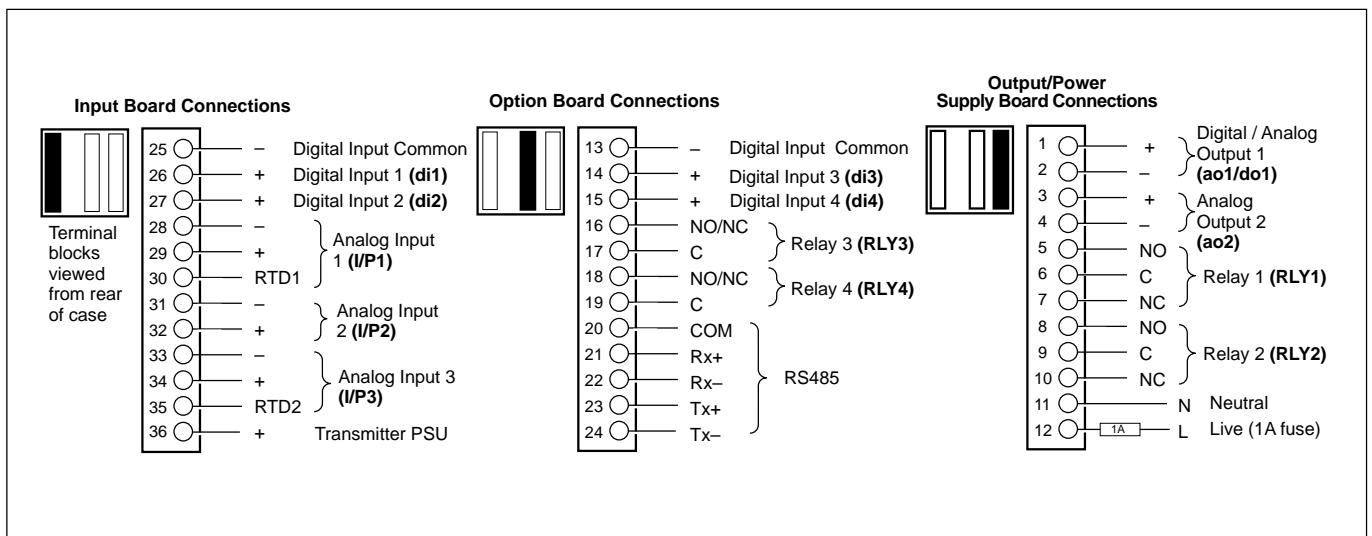

Ordering Guide

COMMANDER 351 Universal Process Controller	C351 /	X X	X	X /	X X X X
Option Board					
None		0 0			
Two digital inputs + Two relays		0 1			
Two digital Inputs + Two relays + RS485 MODBUS		0 2			
Power Supply					
85V to 265V a.c.			0		
24V d.c.			1		
Build					
ABB Standard				0	
CSA approval (pending)				1	
UL approval (pending)				2	
Programming/Special Features					
Configured to factory standard					S T D
Configured to customer detail					C U S
Agreed special features					S P X X

Instrument Coding Example

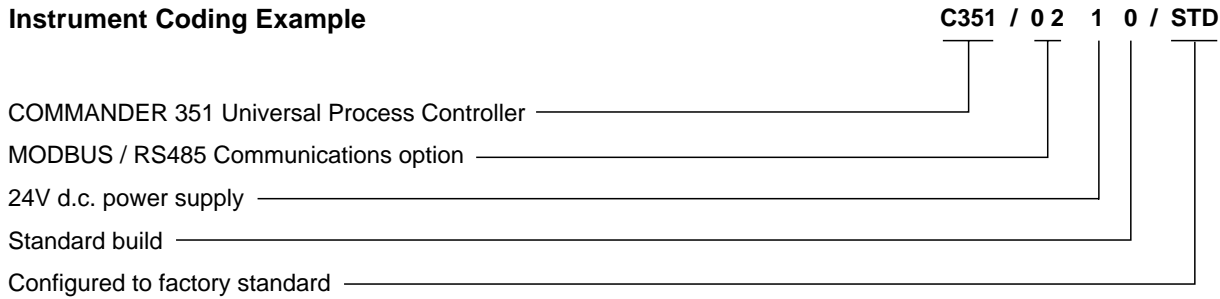

Accessories

PC Configurator kit (including Software and cable) Part No.C100/0700

Licensing, Trademarks and Copyrights

MS Windows is a registered trademark of Microsoft Corporation

MODBUS is a registered trademark of Modicon Inc.



The Company's policy is one of continuous product improvement and the right is reserved to modify the information contained herein without notice.

© ABB 1999

Printed in UK (01.99)

ABB Instrumentation Ltd

Howard Road
St. Neots, Cambs.
England, PE19 3EU
Tel: +44 (0)1480-475-321
Fax: +44 (0)1480-217-948

ABB Automation Inc

Instrumentation Division
125 E. County Line Road
Warminster, PA 18974 USA
Tel: +1 215-674-6000
Fax: +1 215-674-7183

ABB Instrumentation

22016 Lenno
Como
Italy
Tel: +39 (0)344-58111
Fax: +39 (0)344-58278